

INSTALLER INSTRUCTIONS

CONTENTS

1	DESCRIPTION OF THE BOILER	pag. 73
2	INSTALLATION	pag. 76
3	CHARACTERISTICS	pag. 84
4	USE AND MAINTENANCE	pag. 87

IMPORTANT

When carrying out commissioning of the boiler, you are highly recommended to perform the following checks:

- Make sure that there are no liquids or inflammable materials in the immediate vicinity of the boiler.
- Make sure that the electrical connections have been made correctly and that the earth wire is connected to a good earthing system.
- Open the gas tap and check the soundness of the connections, including that of the burner.
- Make sure that the boiler is set for operation for the type of gas supplied.
- Check that the flue pipe for the outlet of the products of the combustion is unobstructed and has been properly installed.
- Make sure that any shutoff valves are open.
- Make sure that the system is charged with water and is thoroughly vented.
- Check that the circulating pump is not locked (CAUTION: Remember to release the pump coupled with the control panel, if necessary, to protect the electronic control card).
- Purge the system, bleeding off the air present in the gas pipe by operating the pressure relief valve on the gas valve inlet.

FONDERIE SIME S.p.A. of Via Garbo 27 - Legnago (VR) - Italy declares that its hot water boilers, which bear the CE mark under Gas Directive 90/396/CEE and are fitted with a safety thermostat calibrated to a maximum of 110°C, **are not subject** to application of PED Directive 97/23/CEE as they meet the requirements of article 1 paragraph 3.6 of the Directive.

IT

ES

PT

GB

RO

RUS

1 DESCRIPTION OF THE BOILER

1.1 INTRODUCTION

The "FORMAT" wall hung boilers with D.H.W. storage tank allow for a multiple number of requests to be met thanks to the abundance of available water which the capacious tank unit makes possible.

They comply with the European directives 90/396/EEC, 89/336/EEC, 73/23/EEC,

92/42/EEC and the European norms EN 483 - EN 625.

They may be fuelled by natural gas (methane) and butane gas (G30) or propane (G31). In this manual you will find the instructions relative to the following boiler models:

- "FORMAT 25/60 OF"
with electronic ignition and modulation,

open chamber, natural draught.

- "FORMAT 25/60 BF - 30/60 BF"
with electronic ignition and modulation, room sealed, forced draught.

Follow the instructions given in this manual for the correct installation and perfect functioning of the appliance.

1.2 DIMENSIONS

1.2.1 "25/60 OF" model

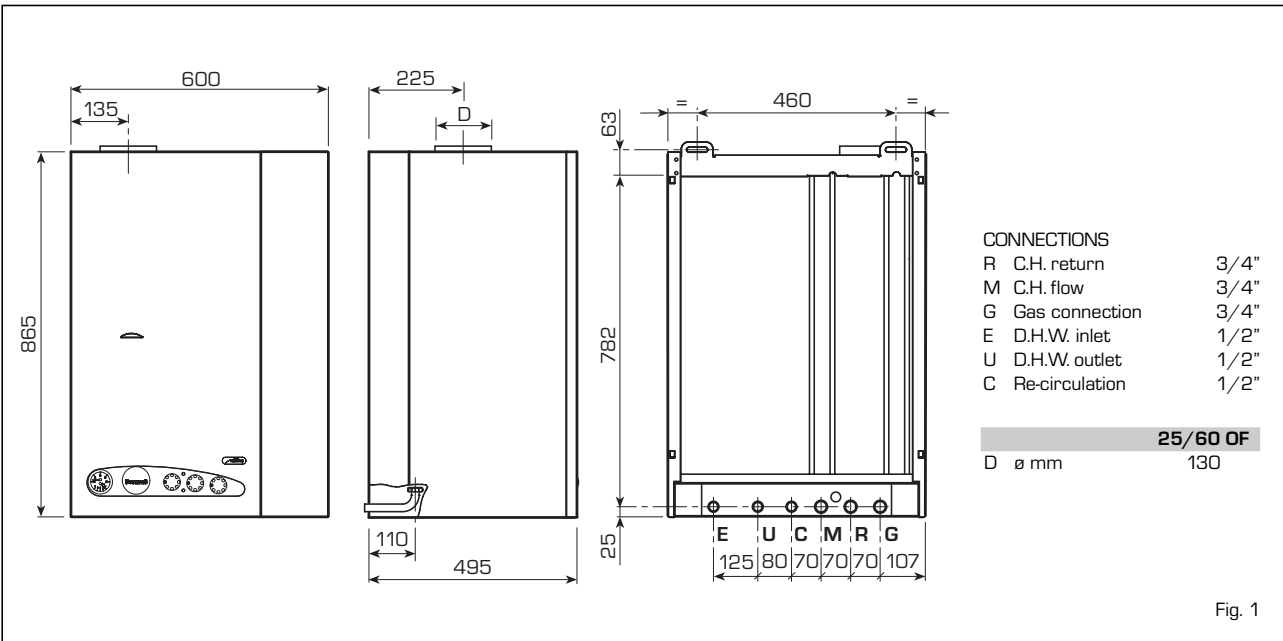

Fig. 1

1.2.2 "25/60 BF - 30/60 BF" models

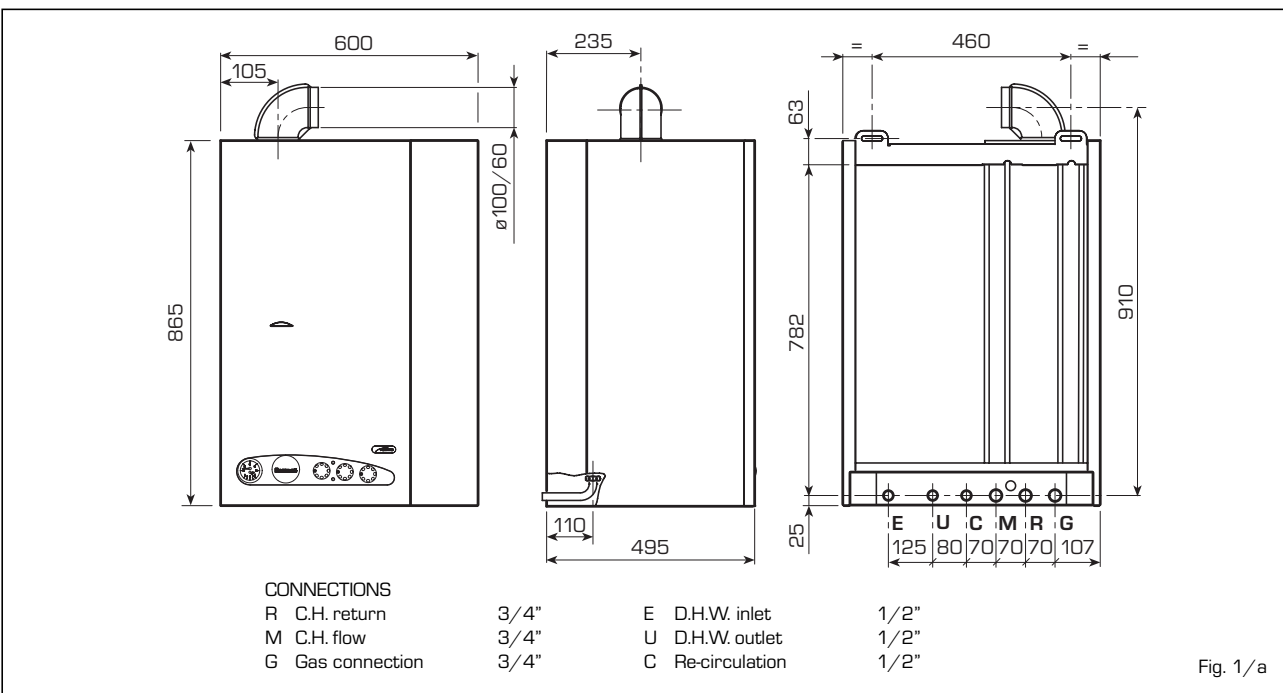

Fig. 1/a



IT

ES

PT

GB

RO

RUS

1.3 TECHNICAL FEATURES

		25/60 OF	25/60 BF	30/60 BF
Heat output				
Nominal	kW	8,4 ÷ 23,2	9,3 ÷ 25,0	11,6 ÷ 29,5
	kcal/h	7.200 ÷ 20.000	8.000 ÷ 21.500	10.000 ÷ 25.400
Minimum	kW	8,4	9,3	11,6
	kcal/h	7.200	8.000	10.000
D.H.W. heat output				
Nominal	kW	23,2	25,0	29,5
Heat input				
Nominal	kW	10,8 ÷ 25,8	10,8 ÷ 26,7	13,5 ÷ 31,6
Minimum	kW	10,8	10,8	13,5
Water content	l	4	4	5
Adsorbed power consumption	W	105	165	180
Electrical protection grade		IP X4D	IP X4D	IP X4D
Maximum water head	bar	3	3	3
Maximum temperature	°C	85	85	85
Expansion vessel				
Water content/Preloading pressure	l/bar	8/1	8/1	8/1
C.H. setting range	°C	40÷80	40÷80	40÷80
D.H.W. setting range	°C	10÷60	10÷60	10÷60
D.H.W. production				
Tank capacity	l	60	60	60
Continuous D.H.W. flow rate at Δt 30°C	l/h	684	684	774
Specific D.H.W. flow rate EN 625 ⁽¹⁾	l/min	14,5	14,5	16,1
D.H.W. maximum water head	bar	7	7	7
Recovery time from 25°C to 55°C	min	4' 30"	4' 30"	4'
D.H.W. expansion vessel	l	2,5	2,5	2,5
Smoke temperature	°C	110	123	123
Smoke flow	gr/s	21,0	17,0	20,0
Category		II _{2H3+}	II _{2H3+}	II _{2H3+}
Type		B _{11B5}	C ₁₂ - C ₃₂ - C ₄₂ - C ₅₂	C ₁₂ - C ₃₂ - C ₄₂ - C ₅₂
Weight	kg	74	82	82
Main gas nozzles				
Quantity	n°	13	13	15
Methane	ø mm	1,30	1,30	1,30
G30 - G31	ø mm	0,75	0,76	0,76
Gas flow ⁽²⁾				
Methane	m ³ st/h	2,73	2,83	3,34
Butane (G30)	kg/h	1,99	2,06	2,44
Propane (G31)	kg/h	1,96	2,03	2,40
Gas burner pressure				
Methane	mbar	1,8÷9,7	1,9÷10,8 ⁽³⁾	1,7÷11,3 ⁽³⁾
Butane (G30)	mbar	4,7÷27,4	4,7÷28,4 ⁽³⁾	4,7÷28,1 ⁽³⁾
Propane (G31)	mbar	6,3÷35,3	4,7÷35,3 ⁽³⁾	4,7÷35,9 ⁽³⁾
Gas supply pressure				
Methane	mbar	20	20	20
Butane (G30)	mbar	30	30	30
Propane (G31)	mbar	37	37	37

(1) Flow calculated with a fixed temperature on the D.H.W. potentiometer of 60 °C for a maximum period of 10 minutes

(2) The gas consumptions refers to the calorific value at standard conditions at 15°C - 1013 mbar

(3) Differential measure between the pressure upstream of the gas valve and the depression in the sealed room

1.4 FUNCTIONAL DIAGRAM

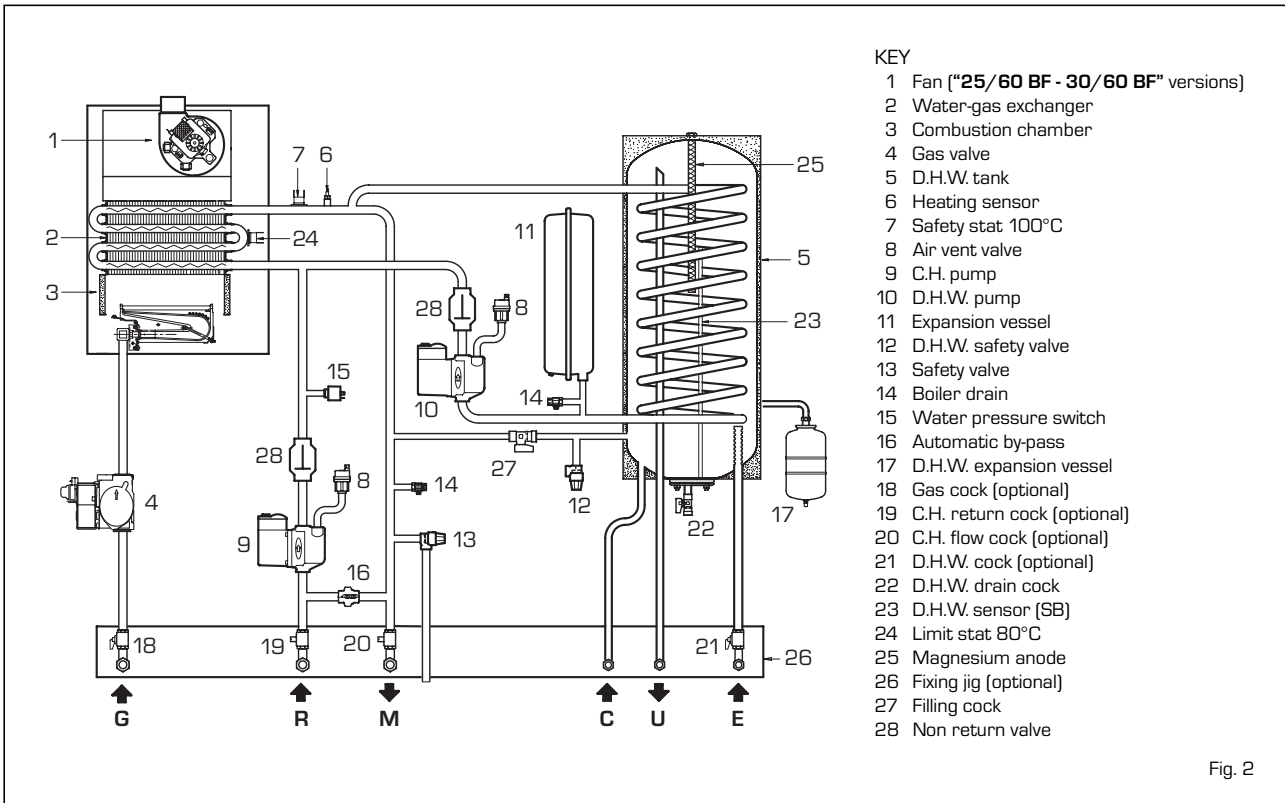

1.5 MAIN COMPONENTS

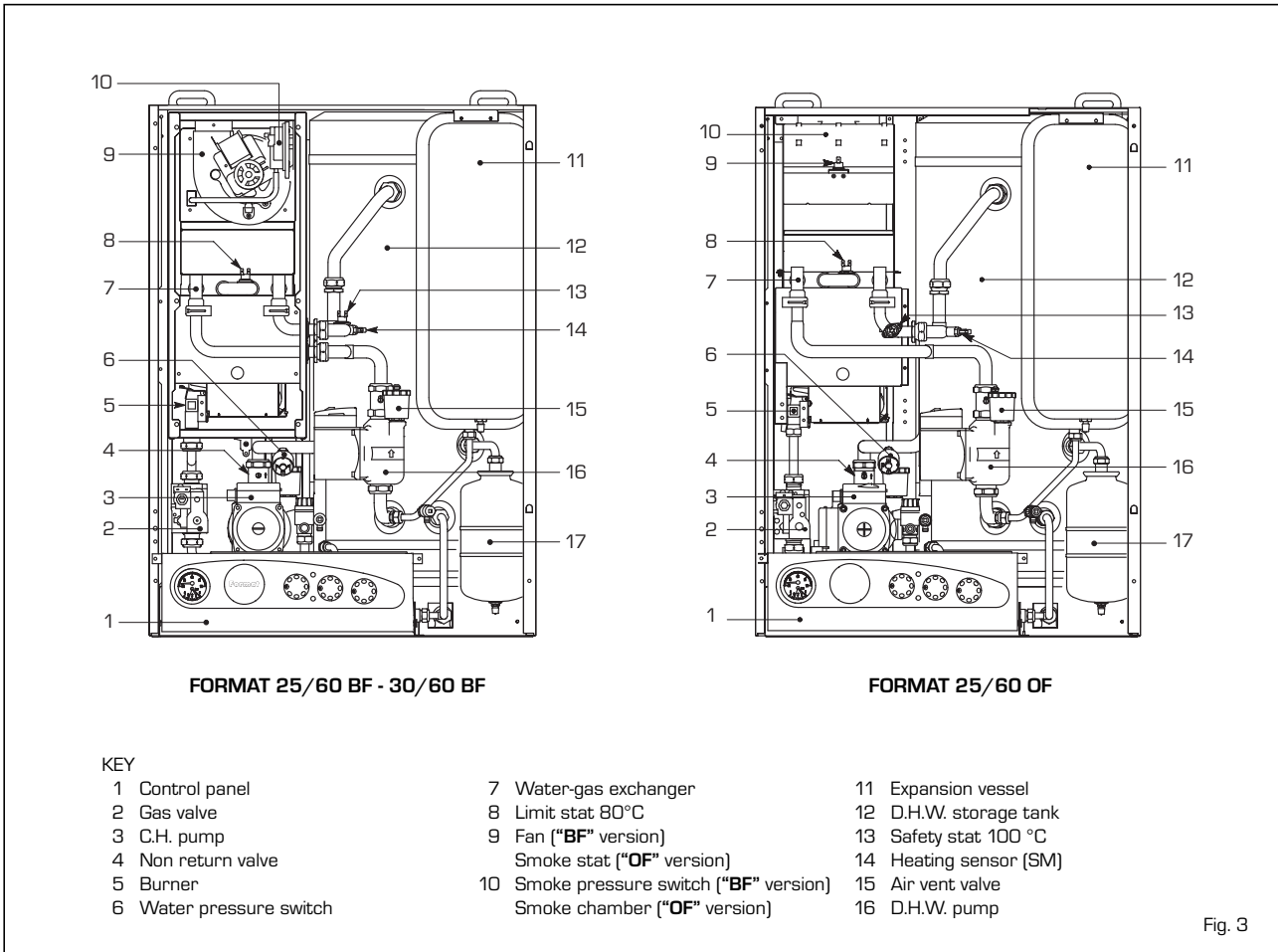

2 INSTALLATION

IT

ES

PT

GB

RO

RUS

The boiler must be installed in a fixed location and only by specialized and qualified firms in compliance with all instructions contained in this manual.

Furthermore, the installation must be in accordance with current standards and regulations.

2.1 VENTILATION OF BOILER ROOM

The "25/60 OF" version boilers must be installed in adequately ventilated domestic rooms. It is essential that in rooms where the boiler are installed at least as much air can arrive as required by normal combustion of the gas consumed by the various appliances. Consequently, it is necessary to make openings in the walls for the air inlet into the rooms. These openings must meet the following requirements:

- have a total free section of at least 6 cm² for every kW of heat input, with a minimum of 100 cm²;
- They must be located as close as possible to floor level, not prone to obstruction and protected by a grid which does not reduce the effective section required for the passage of air.

The "25/60 BF - 30/60 BF" version boilers may instead be installed, without any constraints regarding location or supply of air for combustion, in any domestic rooms.

2.2 BOILER SUPPORT BRACKET

For the mounting of the support bracket of the boiler, which is supplied, observe the following instructions (fig. 4):

- Fix the bracket to the wall with appropriate dowels.

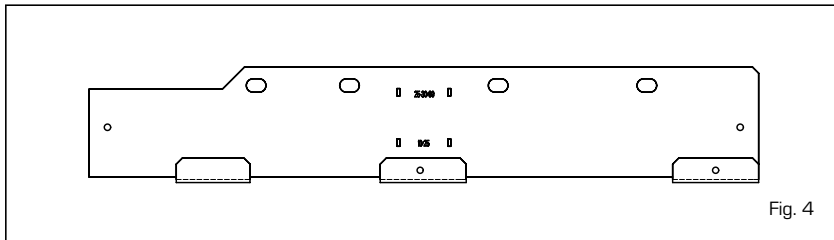

Fig. 4

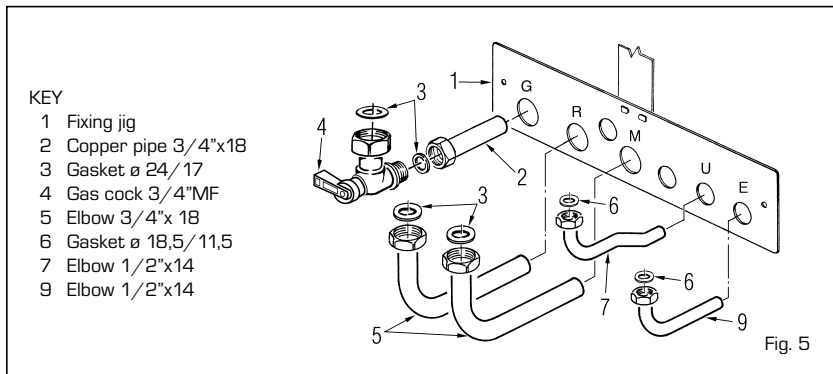

Fig. 5

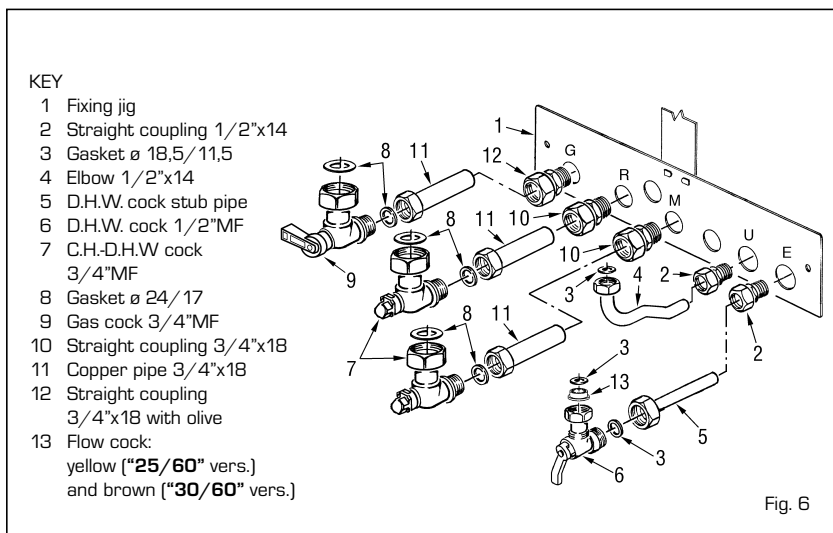

Fig. 6

- Check with a spirit level that it is perfectly in horizontal plane.

2.2.1 Fixing jig (optional)

The fixing jig code 8081209 is supplied with an instruction sheet for the fixing.

2.2.2 Fitting the pipe elbows (optional)

To fit the connecting elbows supplied in kit code 8075419, follow the instructions reported in fig. 5.

2.2.3 Fitting isolating valves (optional)

To fit the isolating valves, supplied in kit code 8091807, follow the instructions mentioned in fig. 6.

2.2.4 Replacement wall kit for other makes (optional)

The kit code 8093900 is supplied complete with mounting instructions.

2.3 CONNECTING UP SYSTEM

Before proceeding to connect up the boiler, you are recommended to make the air circulating in the piping in order to eliminate any foreign bodies that might be detrimental to the operating efficiency of the appliance. When making the hydraulic connections, make sure that the dimensions indicated in fig. 1 are respected.

The discharge pipe of the safety valve must be connected to a collector funnel for channelling away any discharge if the safety valve goes into action.

The gas connection must be made using seamless steel pipe (Mannesmann type), galvanized and with threaded joints provided with gaskets, excluding three-piece connections, except for initial and end connections. Where the piping has to pass through walls, a suitable insulating sleeve must be provided. When sizing gas piping, from the meter to the boiler, take into account both the volume flow rates (consumption) in m³/h and the relative density of the gas in question.

The sections of the piping making up the system must be such as to guarantee a supply of gas sufficient to cover the maximum demand, limiting pressure loss between the gas meter and any apparatus being used to not greater than:

- 1.0 mbar for family II gases (natural gas);
- 2.0 mbar for family III gases (butane or propane).

An adhesive data plate is stuck inside the front panel; it contains all the technical data identifying the boiler and the type of gas for which the boiler is arranged.

2.3.1 Filter on the gas pipe

The gas valve is supplied ex factory with an inlet filter, which, however, is not adequate to entrap all the impurities in the gas or in gas main pipes. To prevent malfunctioning of the valve, or in certain cases even to cut out the safety device with which the valve is equipped, install an adequate filter on the gas pipe.

2.4 CHARACTERISTICS OF FEEDWATER

To prevent lime scale and damage to the tap water exchanger; the water supplied should have a hardness of no more than 20°F. In all cases the water used should be tested and adequate treatment devices should be installed. To prevent lime scale or deposits on the primary exchanger; the water used to supply the heating circuit should must be treated in accordance with UNI-CTI 8065 standards. It is absolutely essential that the water is to be treated in the following cases:

- very extensive system (with high contents of feedwater);
- frequent addition of makeup water into the system;
- should it be necessary to empty the system either partially or totally.

2.5 SYSTEM FILLING

The filling of the boiler and of the system is carried out by pressing the filling cock located on the bottom of the boiler (fig. 7). The filling pressure of the system cold must be **1 bar**. **Once the filling has been completed, close the filling cock.**

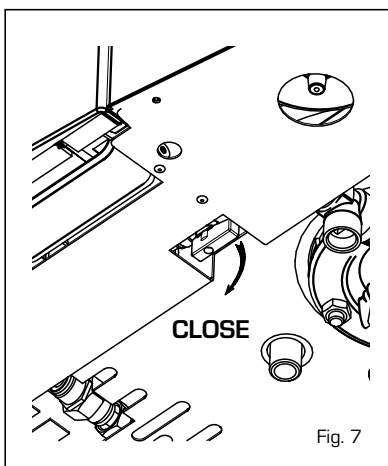

2.6 FLOW REGULATOR (fig. 7/a)

At the inlet of the hot water a flow regulator can be installed, from 10 l/min (yellow) for the "25/60" version and from 12 l/min (brown) for the "30/60" version; the regulator is supplied in the kit of the connecting taps code 8091805.

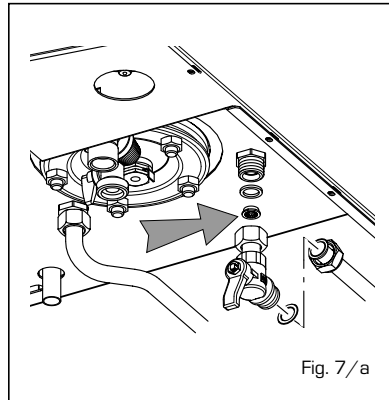

2.7 FLUE

The flue for the atmospherical expulsion of the combustion products from natural draught appliances must meet the following requirements:

- Be gas-tight to the combustion products, waterproof and thermally insulated.
- Be built of materials suitable for keep resisting to normal mechanical stresses, heat, and the action of combustion products and their possible condensates.
- Follow a vertical path and not present any throttling throughout its entire length.
- Be adequately insulated to prevent phenomena of condensation or smokes cooling, in particular if located outside the building or in unheated ambiances.
- Be set at an adequate distance from combustibile or easily inflammable material by means of an air gap or suitable insulating material.
- Have beneath the mouth of the first smoke duct a chamber for collecting solid material and any condensate; the height of the chamber must be at least 500 mm. Access to the chamber must be guaranteed by means of an opening provided with an air-tight metal door.
- Have a circular, square, or rectangular internal cross section; in the case of square or rectangular sections, the corners must be rounded off with a radius of not less than 20 mm. However, hydraulically equivalent cross sections are allowed.
- Be equipped with a chimney-pot at the top, which must be outside the so-called back-flow zone, so as to prevent the formation of back-flow, which prevents free discharge of the products of combustion into the atmosphere.
- Be devoid of mechanical means of suction located at the top of the pipe.
- No overpressure should be present in a chimney that passes within or close up to inhabited rooms.

2.7.1 Connecting up flue

Fig. 8 refers to the connection of the boiler

"25/60 OF" to the flue or chimney through smoke ducts. When making the connection, in addition to respecting the dimensions given, you are recommended to use gas-tight materials capable of resisting over time mechanical stresses and the smokes heat.

At any point along the smoke duct, the temperature of the combustion products must be higher than the dew point. More than a total of three changes of direction must not be made, including the inlet connection to the chimney/flue. For any changes of direction use only curved pipe lengths.

Fig. 8/a shows some applications of draught terminals that ensure proper expulsion of the combustion products, in case of discharge through the wall.

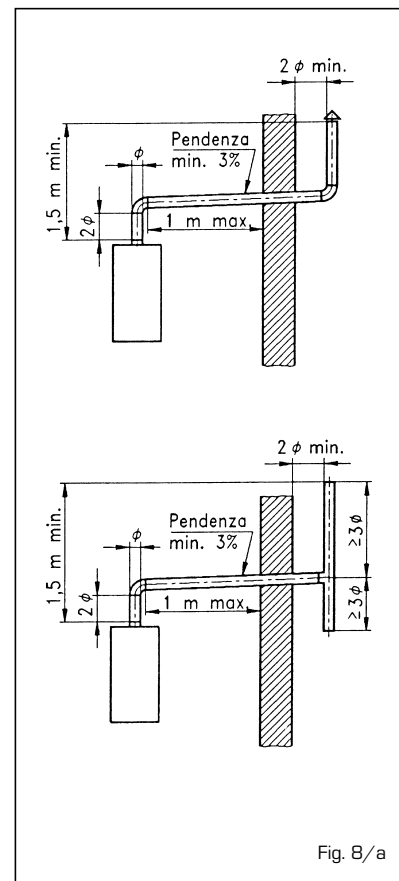
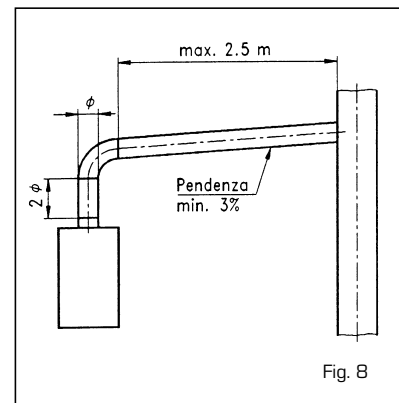

IT

ES

PT

GB

RO

RUS

2.8 COAXIAL DUCT "25/60 BF -30/60 BF"

The coaxial inlet and outlet duct \varnothing 60/100 is supplied in a kit code 8084813 complete with mounting instructions.

2.8.1 Diaphragm installation

The diaphragm is supplied together with the "30/60 BF" boiler version. See figure 9 for the positioning.

ATTENTION:

Install the diaphragm only when the length of the \varnothing 60/100 coaxial duct is less than 1 m.

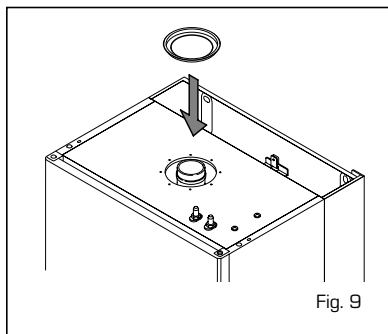

Fig. 9

2.8.2 Coaxial duct accessories

The accessories necessary for the realisation of this type of discharge and some of the connecting systems that can be used are shown in fig. 10.

With the elbow supplied in the kit the maximum length of the duct should not be greater than 3 metres.

2.8.3 Positioning the outlet terminals

The outlet terminals for forced-draught appliances may be located in the external perimeter walls of the building.

To provide some indications of possible solutions, Table 1 gives the minimum distances to be observed, with reference to the type of building shown in fig. 11.

2.8.4 Roof outlet coaxial duct

The roof outlet terminal L1284 cannot be shortened and the positioning of the tile distances must be no less than 600 mm from the discharge terminal outlet (fig. 12). The fittings required for this type of discharge and some of the connecting systems that can be used are shown in fig. 13.

Up to a maximum of three extensions can be added to reach a rectilinear length of 3.7 m. If it proves necessary to provide for

KEY

- 1a-b Coaxial duct kit L. 810 code 8084813
- 2a Extension L.1000 code 8096100
- 2b Extension L.500 code 8096101
- 3 Vertical extension L.200 code 8086908
- 4 Supplementary 90° elbow code 8095800

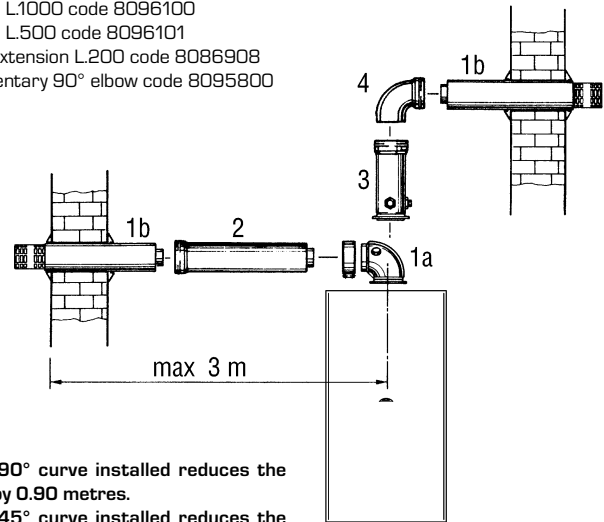

IMPORTANT:

Each additional 90° curve installed reduces the available length by 0.90 metres.
Each additional 45° curve installed reduces the available length by 0.45 metres.

Fig. 10

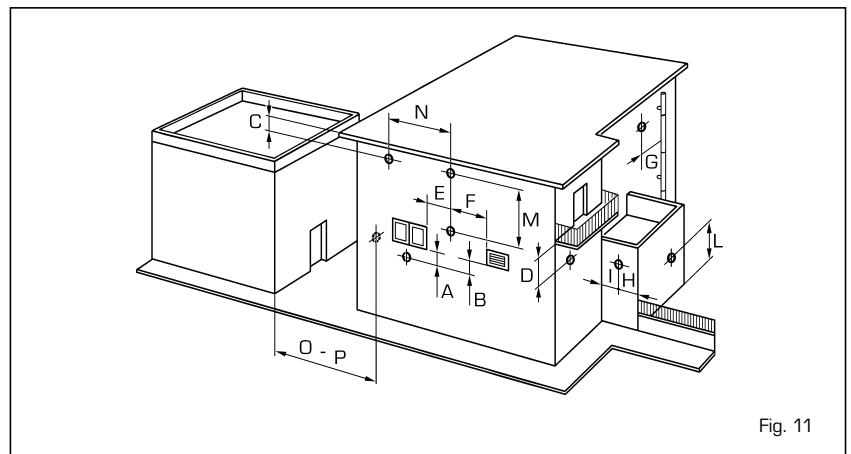

Fig. 11

TABLE 1

Siting of terminal	Appliances from 7 to 35 kW (distances in mm)
A - below openable window	600
B - below ventilation opening	600
C - below eaves	300
D - below balcony [1]	300
E - from adjacent window	400
F - from adjacent ventilation opening	600
G - from horizontal or vertical soil or drain pipes [2]	300
H - from corner of building	300
I - from recess in building	300
L - from ground level or other treadable surface	2500
M - between two terminals set vertically	1500
N - between two terminals set horizontally	1000
O - from a surface facing without openings or terminals	2000
P - as above but with openings and terminals	3000

- 1) Terminals below a practicable balcony must be located in such a way that the total path of the smoke from its outlet point from the terminal to its outlet point from the external perimeter of the balcony, including the height of possible railings, is not less than 2000 mm.
- 2) When siting terminals, where materials that may be subject to the action of the combustion products are present in the vicinity, e.g., eaves, gutters and downspouts painted or made of plastic material, projecting timberwork, etc., distances of not less than 1500 mm must be adopted, unless adequate shielding is provided to guard these materials.

two changes of direction in the duct, the maximum length must not be greater than 2 m.

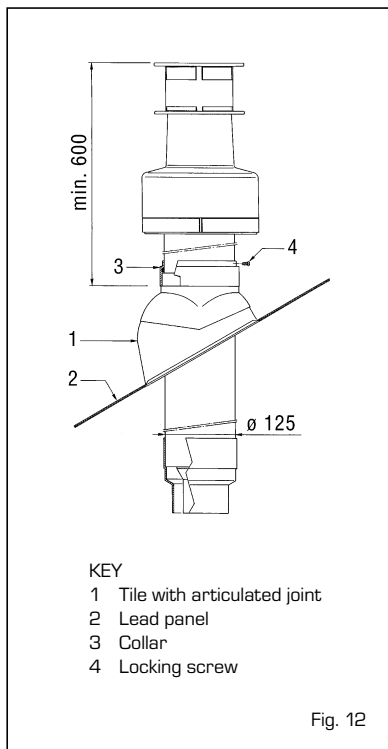

Fig. 12

2.9 SEPARATE DUCTS "25/60 BF -30/60 BF"

In the installation it is best to observe the directions requested by the Norms and a few practical considerations:

- With direct external suction, when the duct is than 1 m in length, insulation is recommended in order to avoid, in particularly cold periods, the formation of dew on the outside of the tubing.
- With discharge duct positioned on the outside of the building, or in cold environments, insulation is necessary to avoid starting failures of the burner. In such cases, a system for the collection of condensation must be organised.
- If a segment of the flue passes through a flammable wall, this segment must be insulated with a glass wool pipe insulator 30 mm thick, with a density of 50 kg/m³.

The maximum total length obtained by summing up the lengths of the suction and discharge tubing is determined by the load losses of the single fittings attached (excluding the splitter) and must not be greater than 8.00 mm H₂O (vers. "25/60") and 9.00 mm H₂O (vers. "30/60"). For the load losses of the fittings refer to Table 2.

2.9.1 Fittings separate ducts

A kit code 8093000 (fig. 14) is supplied for

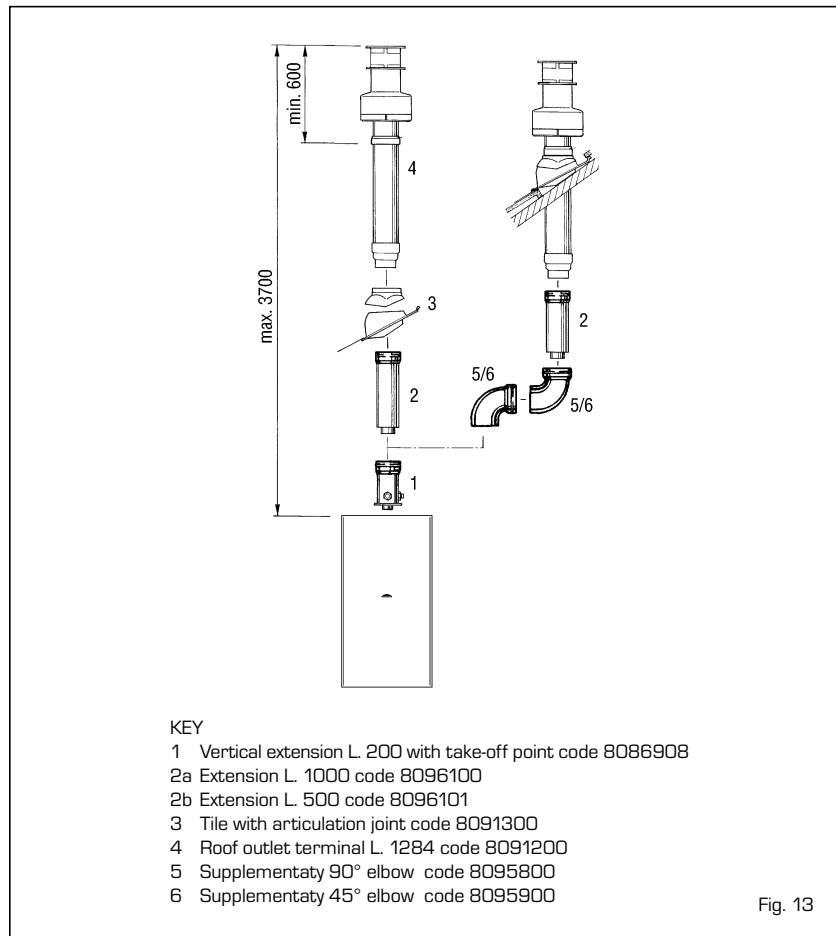

Fig. 13

the realisation of this type of discharge.

The sector diaphragm that comes with the kit must be used as indicated in fig. 15 according to the maximum load loss

allowed in both ducts.

The complete range of the fittings necessary for each type of installation is given in fig. 16.

TABLE 2

Accessories ø 80	Head loss (mm H ₂ O)					
	"25/60" version			"30/60" version		
	Inlet	Outlet	Roof outlet	Inlet	Outlet	Roof outlet
90° elbow MF	0.30	0.40	-	0.30	0.50	-
45° elbow MF	0.20	0.30	-	0.20	0.40	-
Extension L. 1000 (horizontal)	0.20	0.30	-	0.20	0.40	-
Extension L. 1000 (vertical)	0.30	0.20	-	0.30	0.30	-
Outlet terminal	-	0.30	-	-	0.40	-
Intake terminal	0.10	-	-	0.10	-	-
Doubler fitting	0.20	-	-	0.30	-	-
Roof outlet terminal L. 1390	-	-	0.50	-	-	0.60
Tee condensation outlet	-	1.00	-	-	1.10	-

Example of allowable installation calculation ("25/60" version) in that the sum of the head losses of the single fittings is less than 8.00 mm H₂O:

	Intake	Outlet
7 meter horizontal pipe ø 80 x 0.20	1.40	-
7 meter vertical pipe ø 80 x 0.30	-	2.10
n° 2 90° elbows ø 80 x 0.30	0.60	-
n° 2 90° elbows ø 80 x 0.40	-	0.80
n° 1 terminal ø 80	0.10	0.30
Total head loss	2.10	+ 3.20 = 5.3 mm H₂O

With this total head loss, remove the ø 38 baffle from the intake pipe.

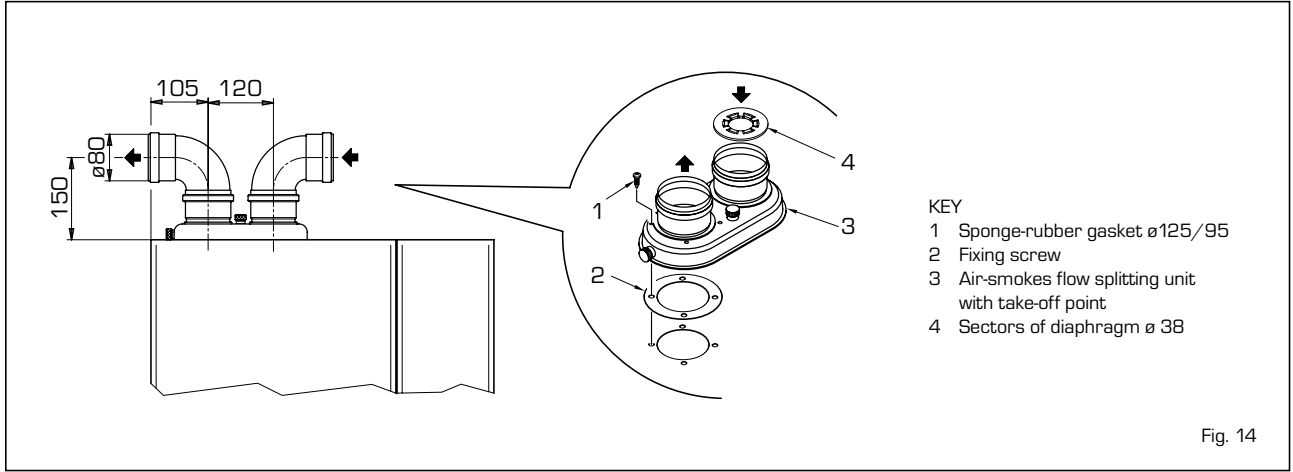

Fig. 14

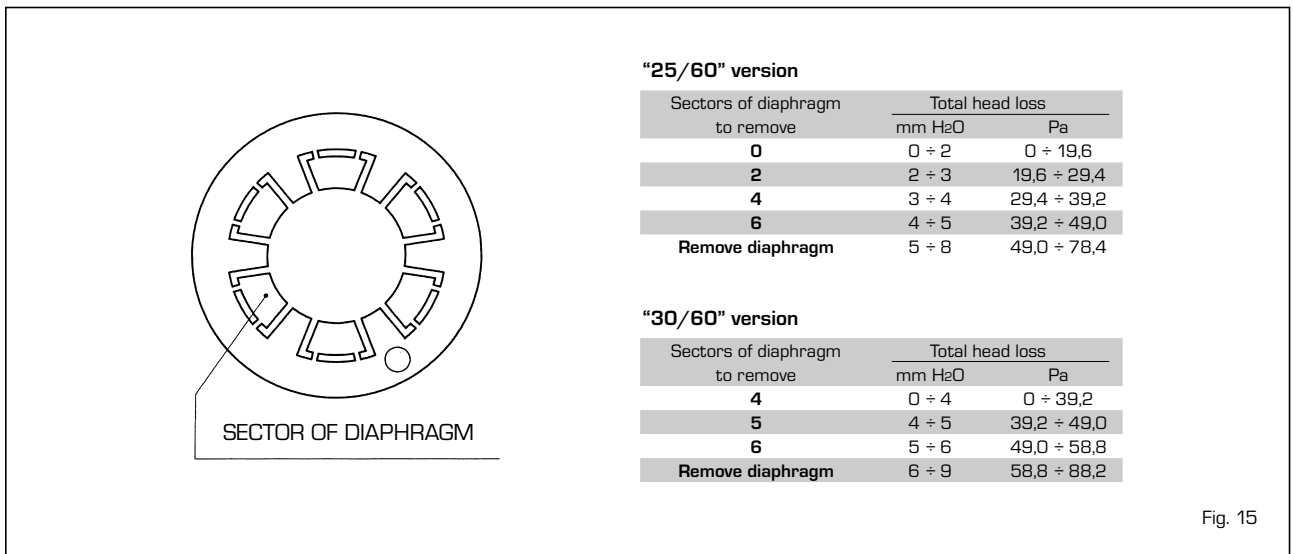

Fig. 15

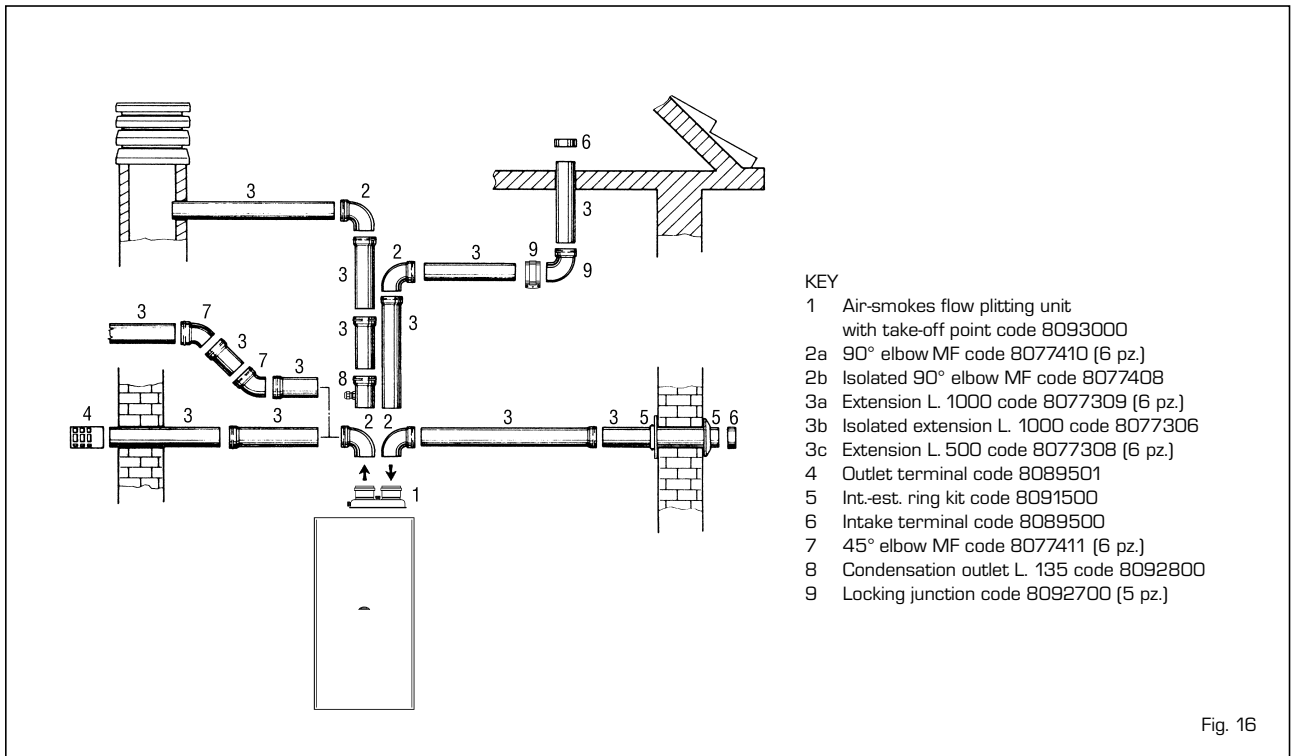

Fig. 16

2.9.2 Roof outlet separate ducts

The roof outlet terminal L. 1390 cannot be shortened and in the positioning of the tile the distance from the discharge outlet of the terminal must not be less than 700 mm (fig. 17). The fittings necessary for this type of discharge and some of the other type of systems that it is possible to use are shown in fig. 18. By utilising the manifold (7 fig. 18) it is possible to have a concentric discharge. In these cases, during assembly, it is necessary to get the washer in silicon used on the reduction of the terminal (5 fig. 17) to be substituted with the manifold and place it in the housing of the manifold.

For this type of discharge the sum of the maximum development allowed of the ducts must not be greater than 8.00 mm H₂O (vers. "25/60") - 9.00 mm H₂O (vers. "30/60").

To calculate the load losses of the single fittings attached refer to **Table 2**.

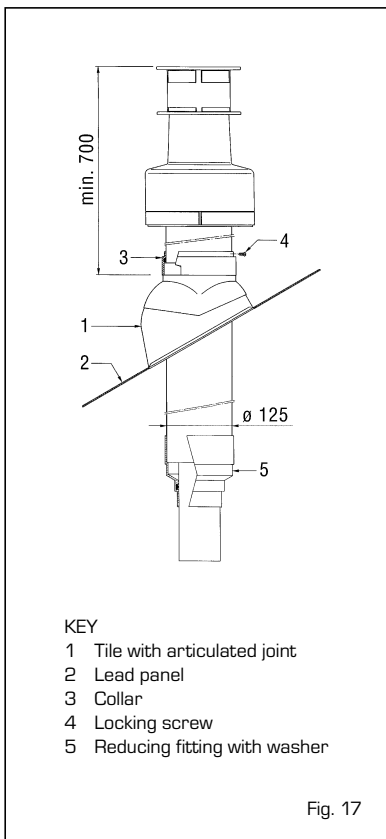

2.10 ELECTRICAL CONNECTION

The boiler is supplied with an electric supply cable, which in case of replacement must be requested from SIME. The supply must be carried out with a monophasic voltage of 230V - 50 Hz via a general switch protected by fuses, with a distance between contacts of at least 3 mm. Observe the L/N polarities and the earth connection.

NOTE: Device must be connected to an efficient earthing system. SIME declines

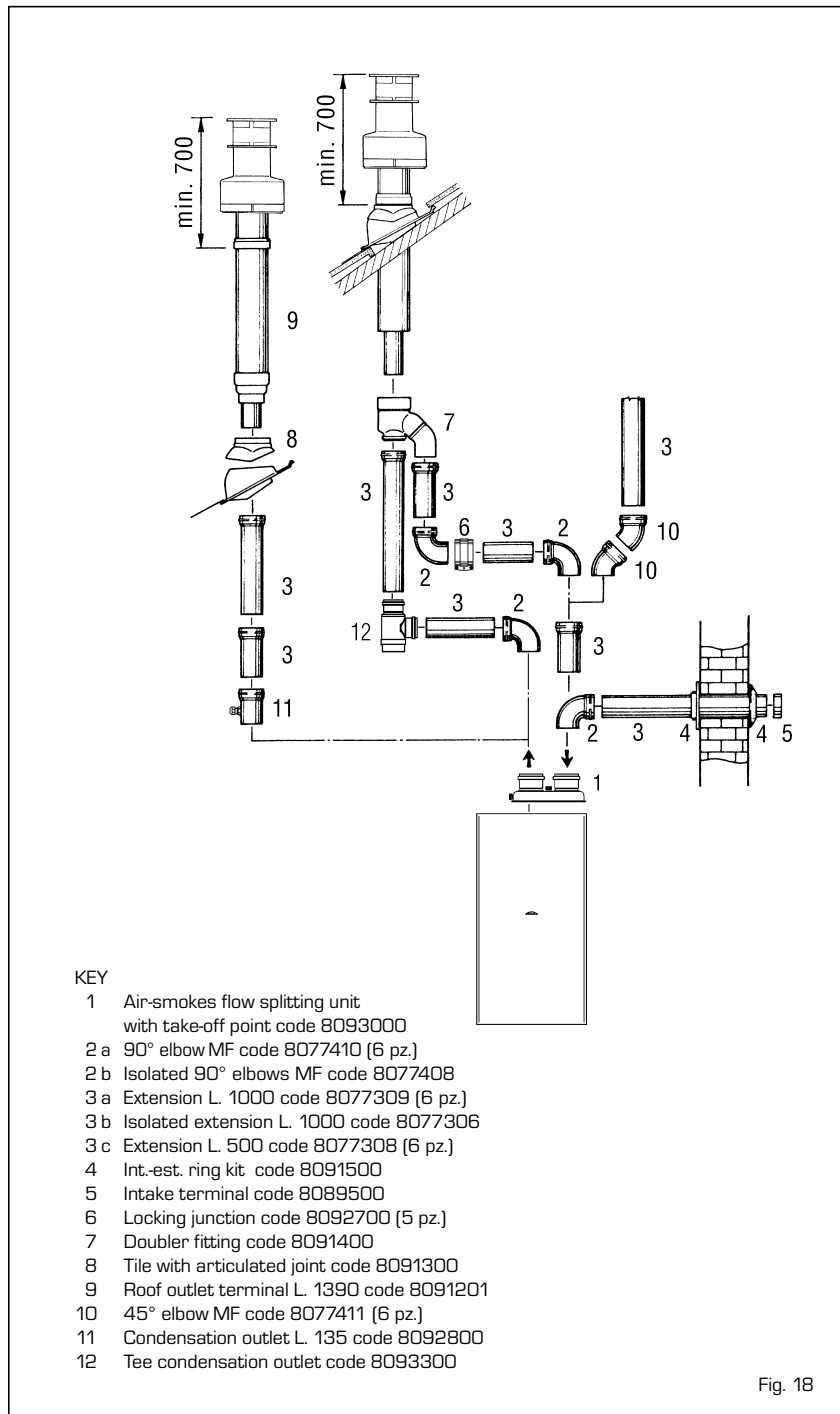

any responsibility for damages to persons or objects due to failing to earth the boiler.

2.10.2 Room stat connection (fig. 19)

2.10.1 Control board (fig. 19)

To access the electrical panel, turn off the power supply and then remove the front panel and the two screws that anchor the control panel to the sides (see point 4.6). The panel will move towards the bottom at an angle that will allow access to the components. To remove the protection (6) unscrew the fixing screws and with a screwdriver press on the upper splines to detach them from the control panel.

In order to have access to the "TA" connector, remove the cover (7) of the control panel and electrically connect the room stat to the terminals 10-11 after having removed the existing bridge.

The thermostat or chronothermostat to be used, whose installation allows a better regulation of the temperature and comfort of the environment, must be class II in compliance with norm EN 60730.1 (clean electrical contact).

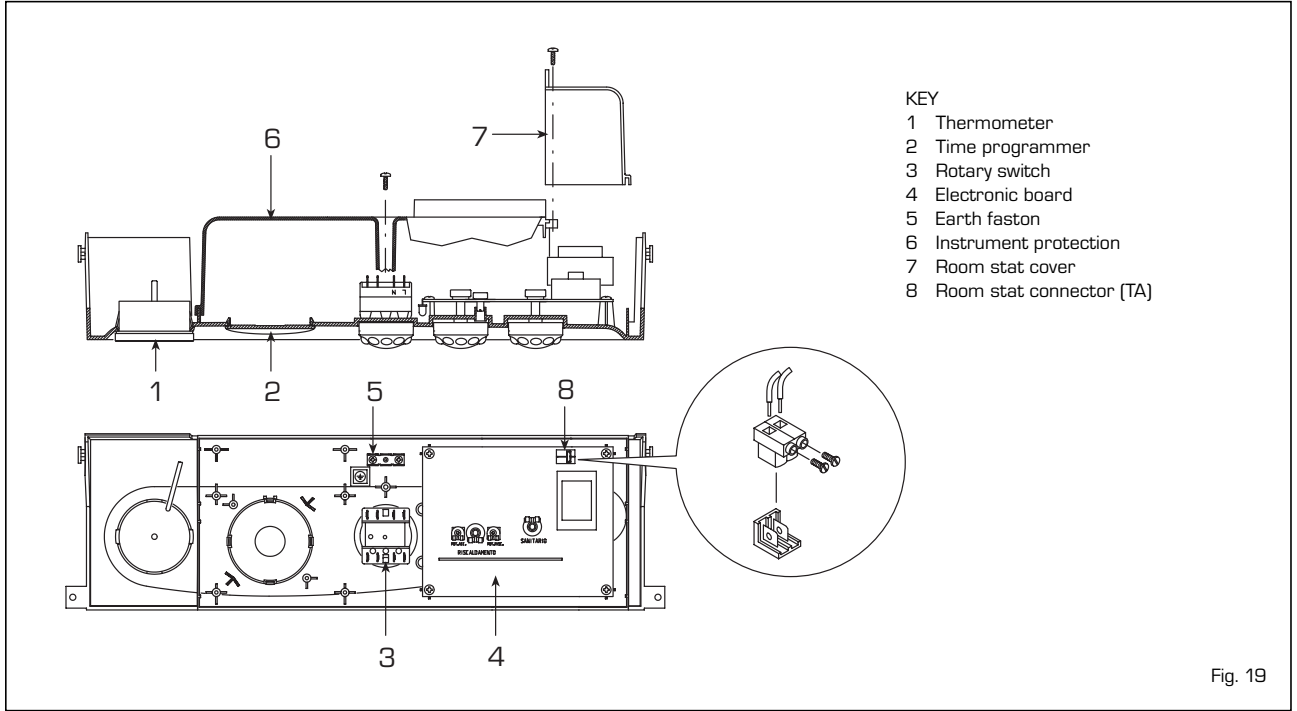

Fig. 19

2.10.3 Wiring diagram "25/60 OF"

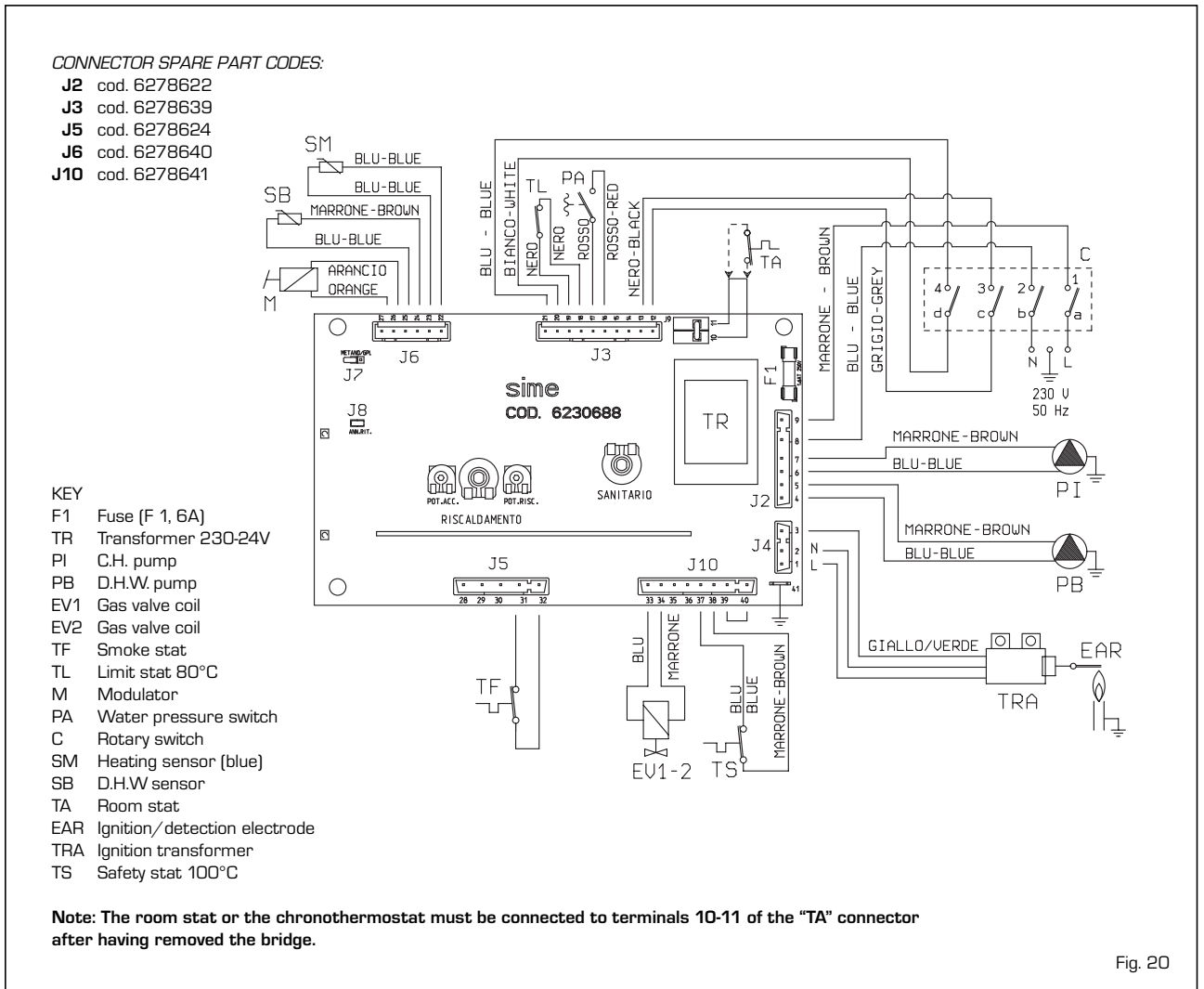

Fig. 20

2.10.4 Wiring diagram "25/60 BF -30/60 BF"

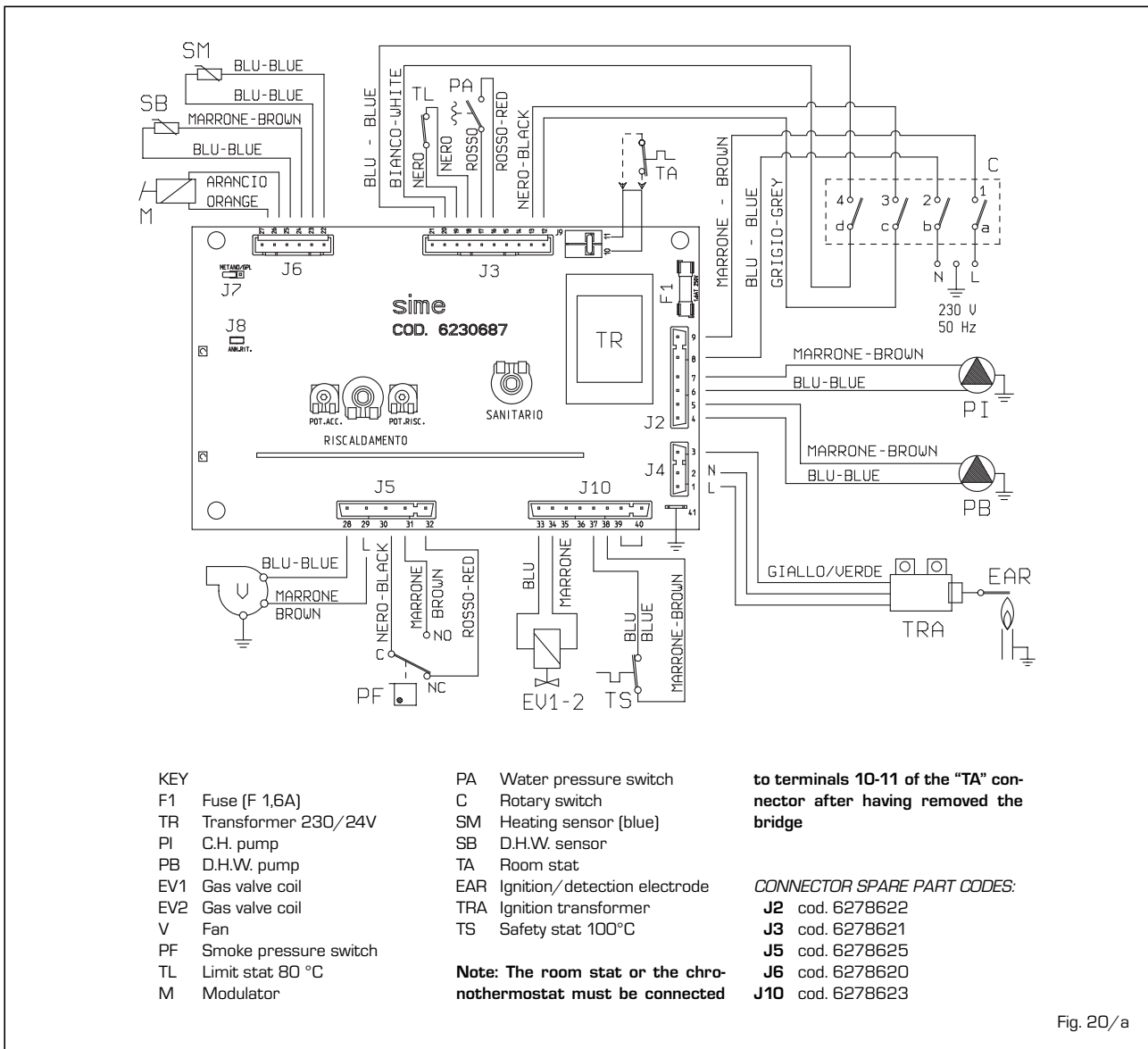

Fig. 20/a

3 CHARACTERISTICS

IT

ES

PT

GB

RO

RUS

3.1 ELECTRONIC BOARD

Made in accordance with the Low Voltage EEC directive 73/23, supplied with 230 Volt; via a transformer it sends 24 Volt to the following components: modulator, C.H. and D.H.W. sensors, gas valve, limit stat, room stat, water pressure switch and time programmer.

An automatic and continuous modulating system allows the boiler to adjust the power to the various systems or user demands. The electronic components are guaranteed to work in a temperature range between 0 and +60 °C.

3.1.1 Functioning faults

The leds that show an irregular and/or incorrect functioning of the boiler are shown in fig. 21.

3.1.2 Devices

The electronic board has the following devices (fig. 22):

- **Trimmer "POT. RISC."** (1)
It regulates the maximum value of heating power. To increase the value turn the trimmer in a clockwise direction and to decrease it turn the trimmer in an anti-clockwise direction.
- **Trimmer "POT. ACC."** (6)
Trimmer to vary the pressure level (STEP) in the ignition of the gas valve. In accordance with the type of gas for

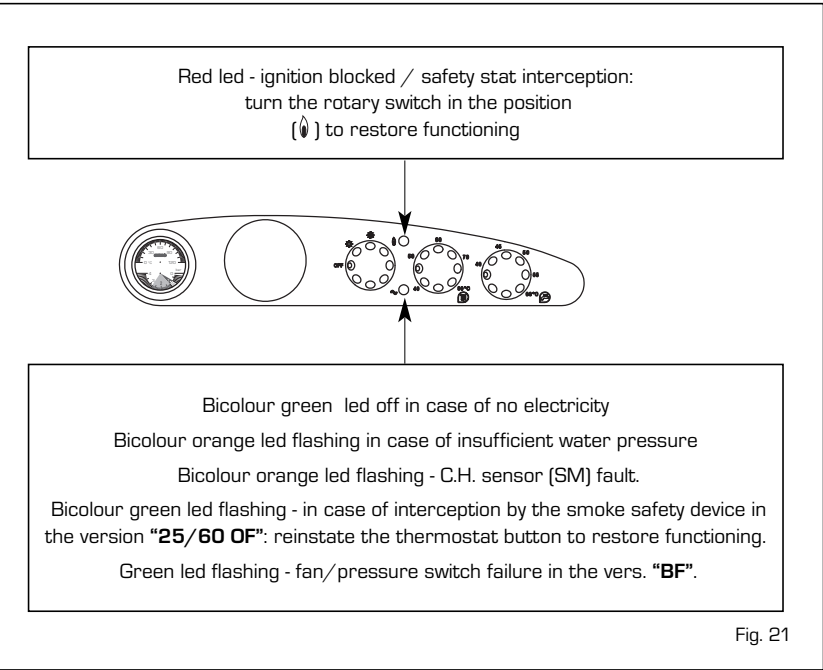
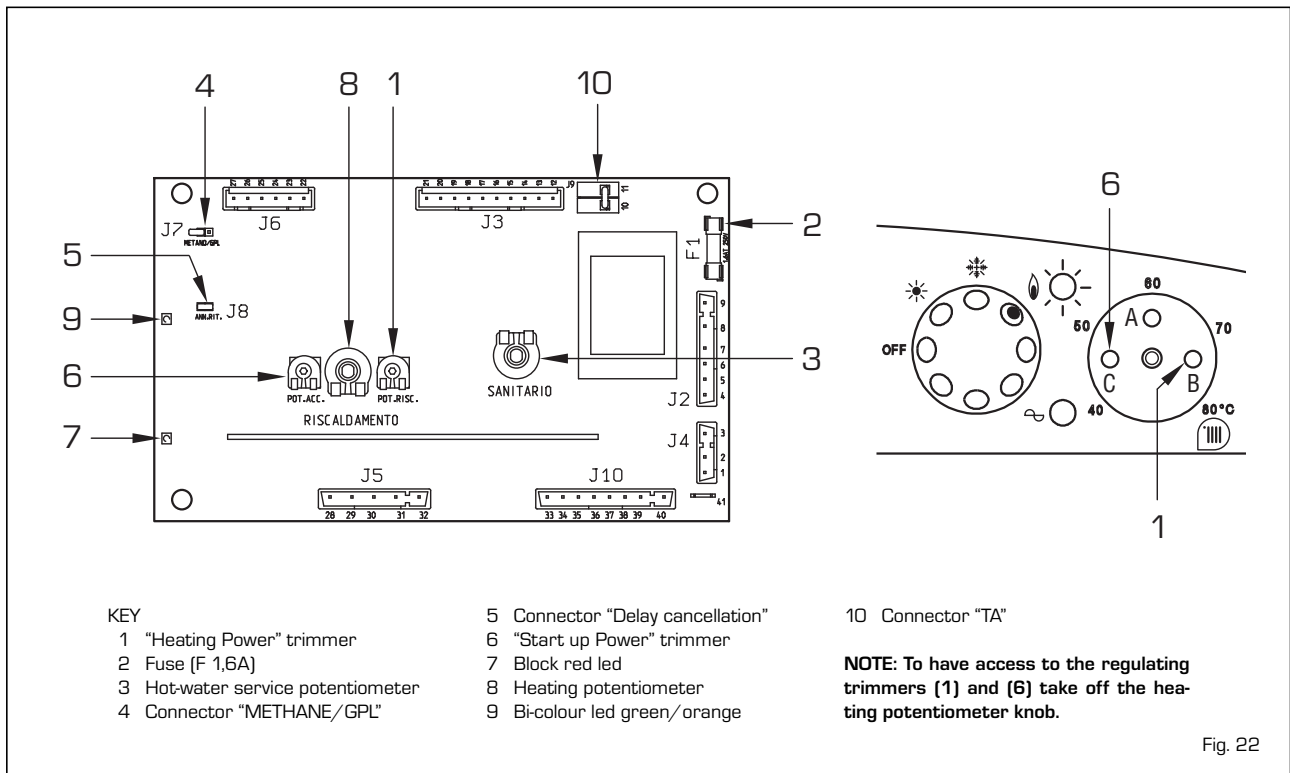

Fig. 21

which the boiler is predisposed, the trimmer must be regulated so as to provide the burner with a pressure of around 3 mbar for methane gas or 7 mbar for butane (G30) and propane gas (G31). To increase the pressure turn the trimmer in a clockwise direction, to decrease it turn the trimmer in an anti-clockwise direction. The level of pressure of slow starting is able to be set during the first 3 seconds from the starting of the burner. After having established the level of

pressure at starting (STEP) according to the type of gas, check that the heating gas pressure is still on the value previously set.

- **Connector "METANO-GPL"** (4)
With the connector disconnected, the boiler is ready to function with METHANE; with the connector connected with GPL.
- **Connector "ANN. RIT."** (5)
The electronic board is programmed, in heating phase, with a technical pause by



- KEY
- 1 "Heating Power" trimmer
 - 2 Fuse (F 1,6A)
 - 3 Hot-water service potentiometer
 - 4 Connector "METHANE/GPL"

- 5 Connector "Delay cancellation"
- 6 "Start up Power" trimmer
- 7 Block red led
- 8 Heating potentiometer
- 9 Bi-colour led green/orange

10 Connector "TA"

NOTE: To have access to the regulating trimmers (1) and (6) take off the heating potentiometer knob.

Fig. 22

the burner of around 90 seconds, both at the beginning when the plant is cold and in subsequent restartings.

This is so to avoid startings and switching off with very short intervals, that may in particular be found in plants with high losses.

At every restarting, following the period of slow starting, the boiler will position itself for around 1 minute to the minimum modulating pressure to then return to the set value of heating pressure.

With the insertion of the bridge both the technical pause programmed and the period of functioning at minimum pressure in the starting phase will be eliminated. In such a case, the time that runs between the switching off and the next starting will be in function of a variance of 5°C, as detected by the heating sensor (SM).

ATTENTION: All of the operations described above must be carried out by authorized personnel.

3.2 TEMPERATURE DETECTION SENSORS

In **Table 3** the resistance (Ω) values are given. They are obtained by the sensors when the temperature varies.

With the C.H. sensor (SM) interrupted the boiler will not function with both services. With the D.H.W. sensor (SB) interrupted the boiler functions only with heating.

TABLE 3

Temperature (°C)	Resistance (Ω)
20	12.090
30	8.313
40	5.828
50	4.161
60	3.021
70	2.229
80	1.669

3.3 ELECTRONIC IGNITION

The ignition and flame sensing are controlled by a single electrode on the burner that guarantees the maximum safety, with a time of intervention of one second for accidental switching off or lack of gas.

3.3.1 Functioning cycle

Turn the rotary switch to summer or winter and note, from the lighting up of the green led, whether electricity is present. We can summarise the manifestations of a failure to start, with consequent activation of the failure signal as follows:

- **Lack of gas**
The ignition electrode continues to spark

for a maximum of 10 seconds, the pilot burner does not start, the apparatus is blocked.

This may occur at the first ignition attempt or after long periods of inactivity with the presence of air in the tubing. May be due to the gas tap being closed or a break in the valve coil, which do not allow opening.

- **The ignition electrode does not spark.**
In the boiler only the gas opening to the burner is noted, after 10 seconds the block signal lights up.

May be due to the fact that the cable of the electrode is interrupted or is not well fixed to the terminal of the ignition transformer. The electrode is earthed or very worn and needs to be substituted. The electronic board is faulty.

Due to a sudden fall in electricity the burner is immediately arrested, once the electricity is restored, the boiler will automatically restart.

3.4 SMOKE SAFETY DEVICE "25/60 OF"

It is a safety measure against the outflow of smoke into the environment due to inefficiency or a partial clogging up of the flue (9 fig. 3). It acts by blocking the gas valve when the release of smoke into the environment is continuous and in such a quantity as to be dangerous. To restart the boiler, and reactivate the button of the thermostat. If the blockage occurs repeatedly a thorough control of the flue will be necessary, making all the modifications and taking all the precautions necessary in order for it to be efficient.

3.5 SMOKE PRESSURE SWITCH "25/60 BF -30/60 BF"

The smoke pressure switch with fixed settings 4.5-6 mm H₂O (vers. "25/60") and 10-13 mm H₂O (vers. "30/60") is able to guarantee the functioning of the boiler even with suction and discharge tubing at the maximum limit length permitted (10 fig. 3). Impurities and the formation of condensation, most probable during the colder periods of the season, could cause starting failure of the boiler.

3.6 WATER PRESSURE SWITCH

A water pressure switch intercepts, blocking the functioning of the burner when the pressure in the boiler is less than 0.5 bar (6 fig. 3).

To restore the functioning of the burner, press on the charging key (fig. 7) and take the pressure to a value between 1-1.2 bar.

3.7 SYSTEM AVAILABLE HEAD

The residual prevalence for the heating plant is represented, according to flow, by the graph in fig. 23.

3.8 TIME PROGRAMMER OPTIONAL (fig. 24)

The control panel allows a time programmer to be utilised for the management of the heating, supplied on request in the kit code 8092203.

For the assembly of the time programmer remove the control panel and the cover for the positioning and, with the panel open, fix the clock to the panel with the screws spe-

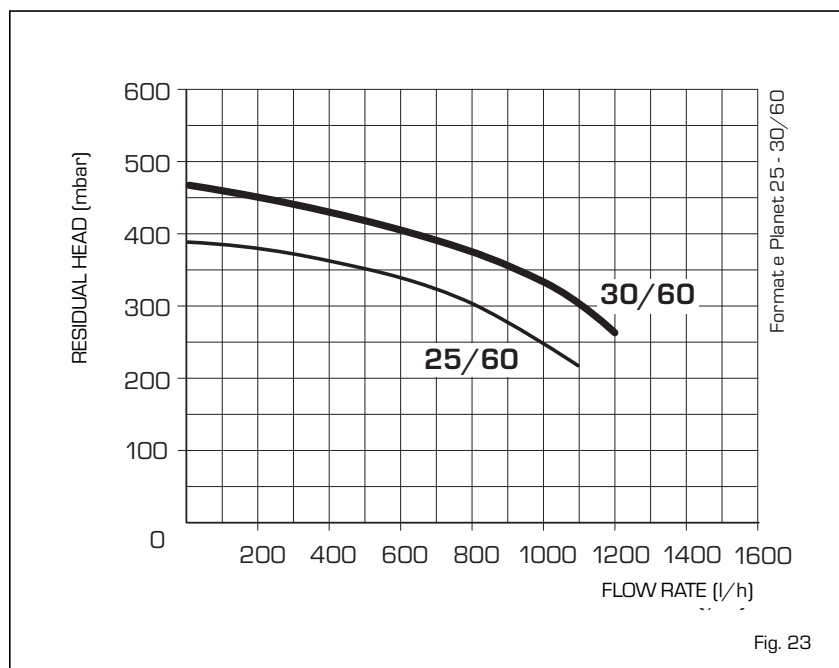

Fig. 23

IT

ES

PT

GB

RO

RUS

cifically supplied.
 Remove the faston that connects terminal 3 of the rotary switch and insert it in terminal 3 of the clock.
 Complete the connection of the electric clock as indicated in the diagram.

3.9 ELECTRICAL CONNECTION ZONE SYSTEMS

Use a separate electric line to link up the room stats and relative zone valves or

pumps.
 The connection of the micros or the relay contacts is carried out on terminals 10-11 of the "TA" connector of electronic panel after having removed the existing bridge [fig. 25].

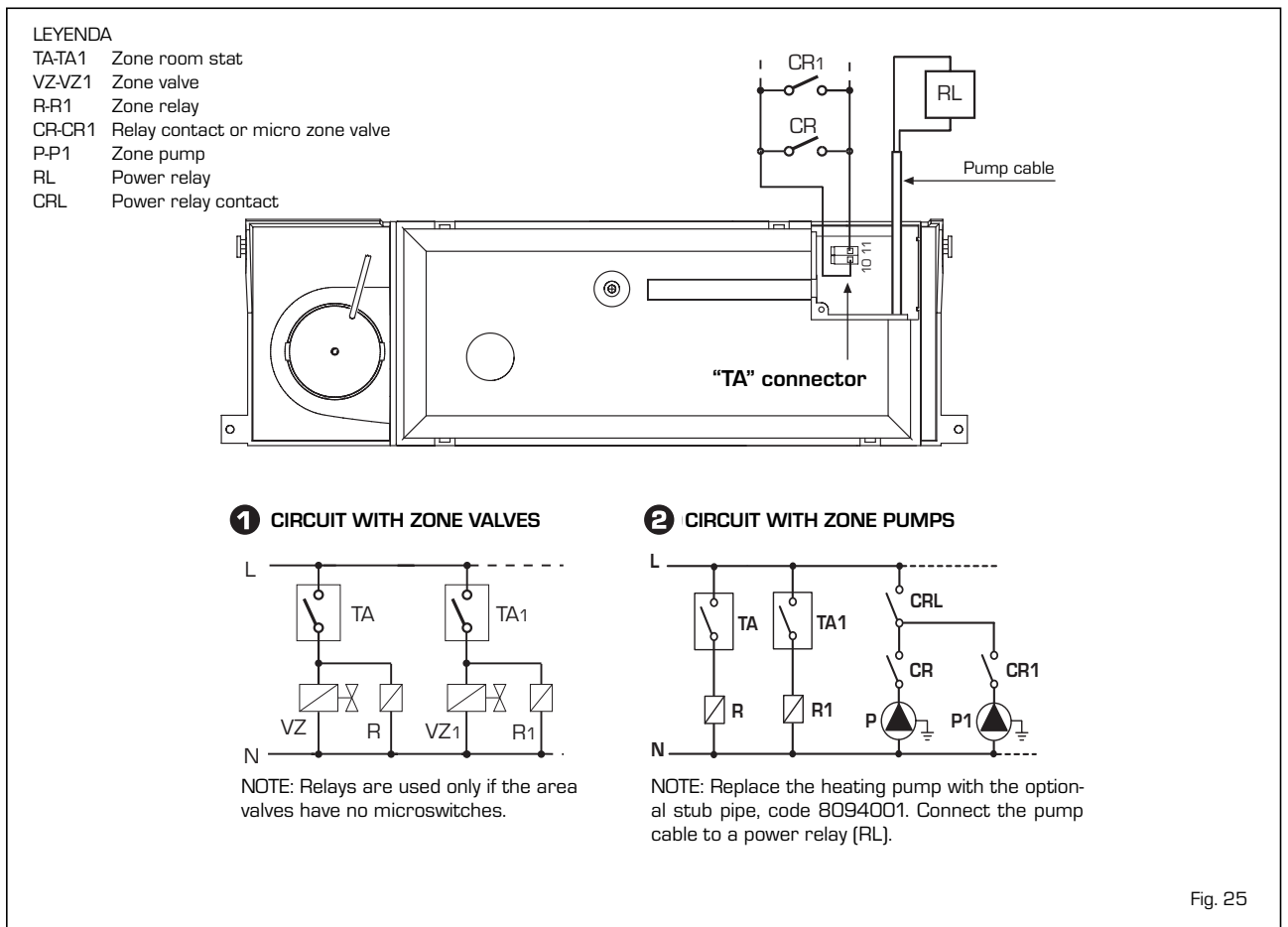
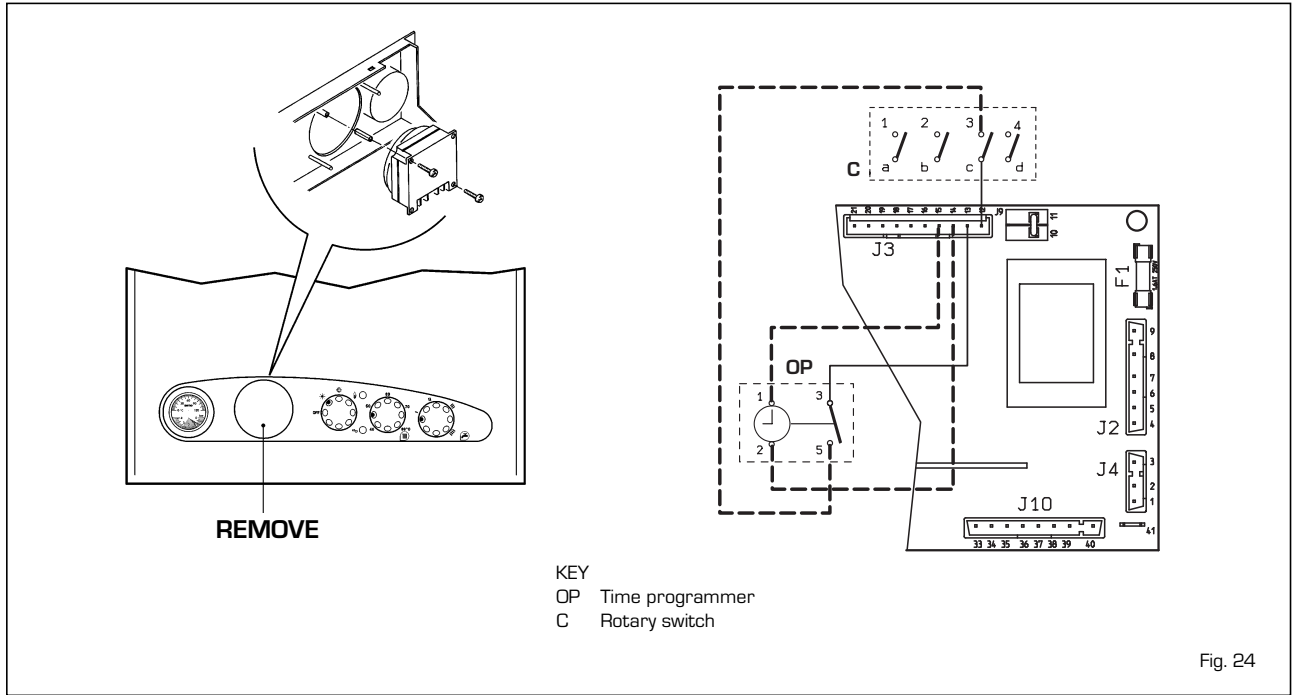

4 USE AND MAINTENANCE

4.1 D.H.W. PRODUCTION

The preparation of hot water is guaranteed by the tank unit in glass enamelled steel with magnesium anode for the protection of the tank unit and inspection flange for its control and cleaning.

The magnesium anode must be checked annually and substituted when it is worn. If the boiler does not produce hot water, make sure that the air has been released by pressing on the manual outlets after having switched off the main switch.

4.2 GAS VALVE

The boiler is produced with gas valve model SIT 845 SIGMA (fig. 26) and gas valve model HONEYWELL VK 4105M (fig. 27). The gas valve is set at two pressure values: maximum and minimum, according to the type of gas, to the values indicated in **Table 4**.

The setting of the gas pressure at minimum and maximum values is carried out by SIME: variations are discouraged. Only in the passing from one type of gas supply (methane) to another (propane) is a change in the working pressure allowed.

Such an operation must be carried out by authorised personnel, or the guarantee will lose validity. Once the change in working pressure has been carried out, seal the regulators.

When the gas pressures are to be reset, this must be done following a set order first setting the MAXIMUM and then the MINIMUM.

4.2.1 Maximum and minimum pressure adjustment SIT 845 SIGMA (fig. 29):

In order to carry out the setting of the maximum pressure proceed in the following way:

- Connect the manometer to the downstream pressure plug of the gas valve.
- In the "BF" versions, instead, connect the manometer as shown in fig. 28.
- Remove the plastic cap of the modulator (1).
- Place the heating potentiometer knob on the maximum value.
- Start the boiler by pressing on the four way switch and the hot water cock.
- Using a \varnothing 10 wrench turn the nut (3) to find the maximum pressure as shown in **Table 4**: to reduce the pressure turn the nut anti-clockwise, to increase the pressure turn the nut clockwise.
- Turn off and turn on the burner a few times whilst keeping the hot water tap constantly open to verify that the pressure corresponds to the values given in **Table 4**.

After having regulated the maximum pressure, proceed with the setting of the minimum pressure:

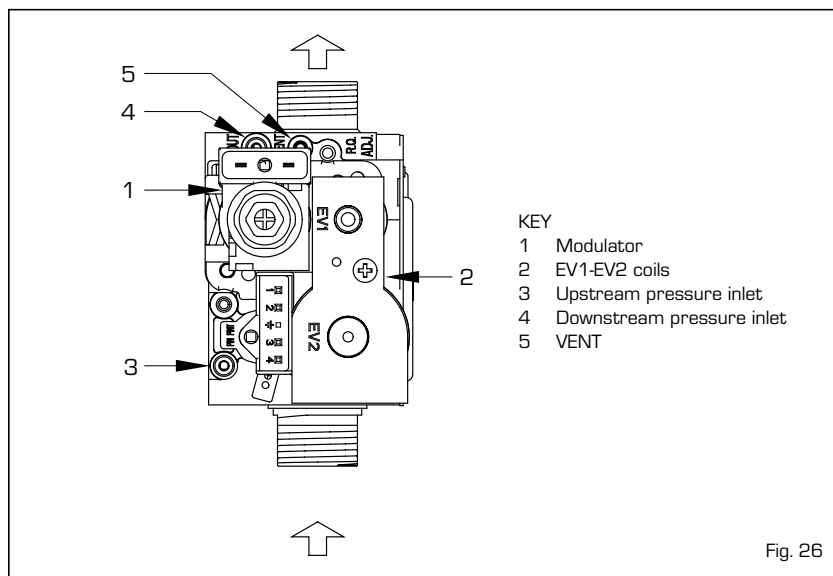

Fig. 26

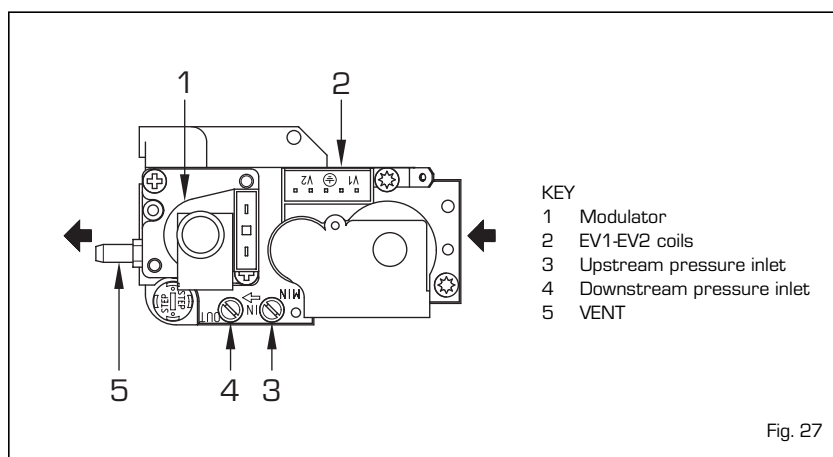

Fig. 27

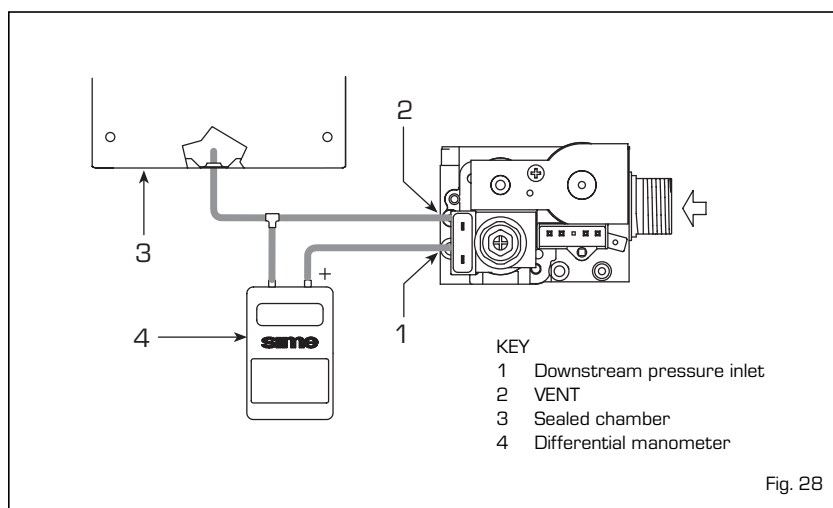

Fig. 28

TABLE 4

Type of gas	Burner max. pressure	Modulator current	Burner min. pressure	Modulator current
	mbar	mA	mbar	mA
Methane (G20)	10 - 11	130	2	0
Butane (G30)	27 - 28	165	5	0
Propane (G31)	35 - 36	165	6 - 5	0

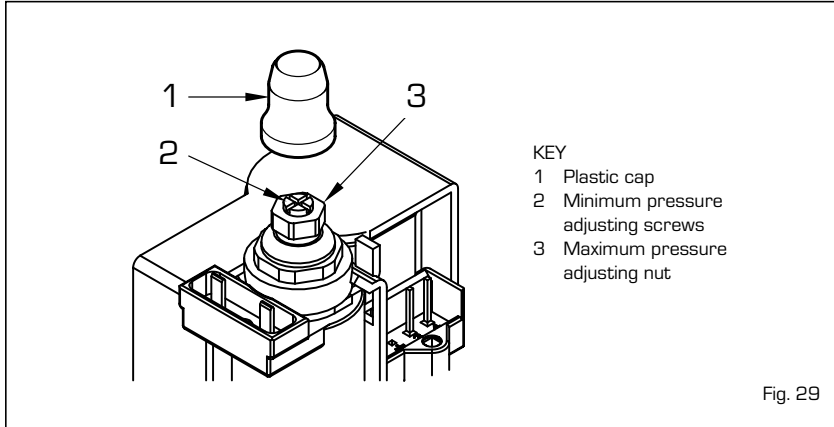

Fig. 29

- Disconnect the electric supply of the modulator.
- With the D.H.W. potentiometer knob on the maximum value, the hot water cock open and the burner alight, holding the nut (3) blocked, turn the screw (2) to find the minimum pressure value as shown in **Table 4**: to decrease the pressure turn the nut anti-clockwise and to increase the pressure turn the nut clockwise.
- Turn on and turn off the burner a few times whilst keeping the hot water cock constantly open and verify that the pressure corresponds to the values fixed.
- Reconnect the electrical supply of the modulator.
- Replace the plastic cap (1).

4.2.2 Maximum and minimum pressure adjustment HONEYWELL VK 4105M (fig. 30)

To set the maximum pressure, proceed as follows :

- Connect the pressure column to the pressure inlet downstream of the gas valve.
- For the "BF" models connect the pressure column as shown in fig. 28.
- Remove the plastic cap on the modulator (1).
- Set the knob of the D.H.W. potentiometer to the maximum value.
- Ignite the boiler and open the D.H.W. cock.
- Using a $\varnothing 9$ spanner, turn the nut (3) to achieve the maximum pressure value given in **Table 4**: to reduce the pressure, turn the nut counterclockwise; to increase the pressure, turn it clockwise.
- Operate the main switch a number of times, keeping the D.H.W. cock open all the time, and check that the pressure corresponds to the values given in **Table 4**.

After adjusting maximum pressure, proceed to calibrate minimum pressure:

- Disconnect the electric power supply from the modulator.
- With the hot water potentiometer knob set to the maximum, the hot water tap turned on and the burner lit, hold nut (3) locked in place and simultaneously turn nut (2) using a fixed $\varnothing 7$

wrench to identify the minimum pressure value shown in **Table 4**: turn the nut anti-clockwise to reduce pressure or clockwise to increase it.

- Turn the boiler on and off repeatedly while keeping the hot water tap turned on, checking that pressure corresponds to the values shown in **Table 4**.
- Connect up the power supply to the modulator again.
- Replace the plastic cap (1).

4.3 ADJUSTMENT OF HEATING OUTPUT

To regulate the heating output, modifying the factory settings whose power value is around 16 kW, it is necessary to work with a screwdriver on the trimmer of the heating power (1 fig. 22).

To increase the operating pressure turn the trimmer in a clockwise direction, to decrease the pressure turn the trimmer in an anti-clockwise direction. To facilitate the search

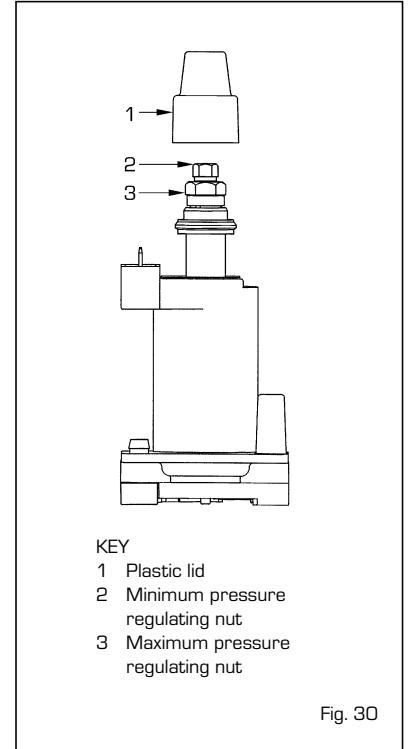

Fig. 30

for the adjusting of the heating power the diagrams pressure/ heat output for natural gas (methane) and butane or propane gas are available (fig. 31).

4.4 CONVERSION TO ANOTHER GAS

For the functioning with butane (G30) or propane (G31) gas, a kit with that needed for the conversion is supplied.

To convert from one gas to another carry out the following operations (fig. 32):

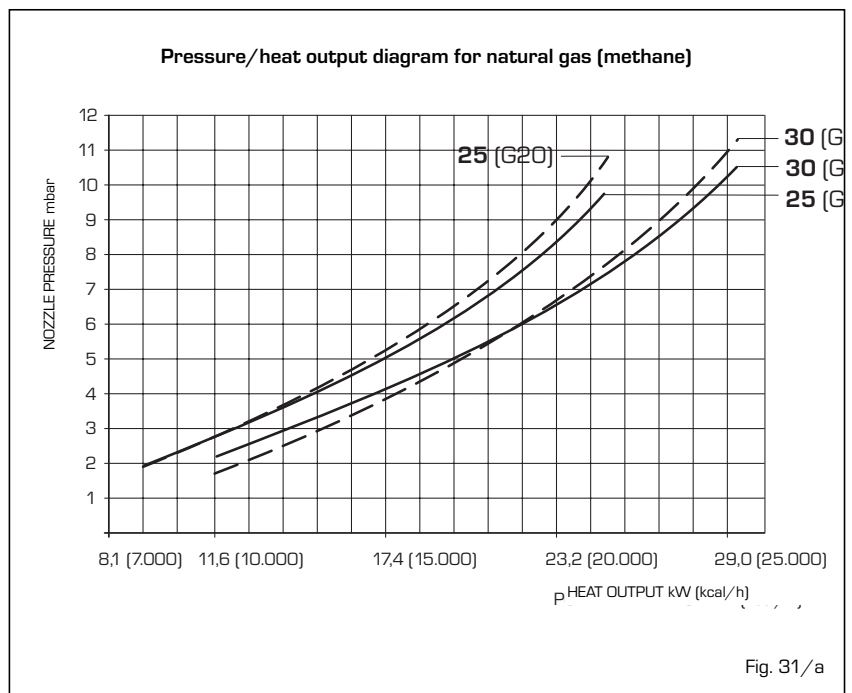

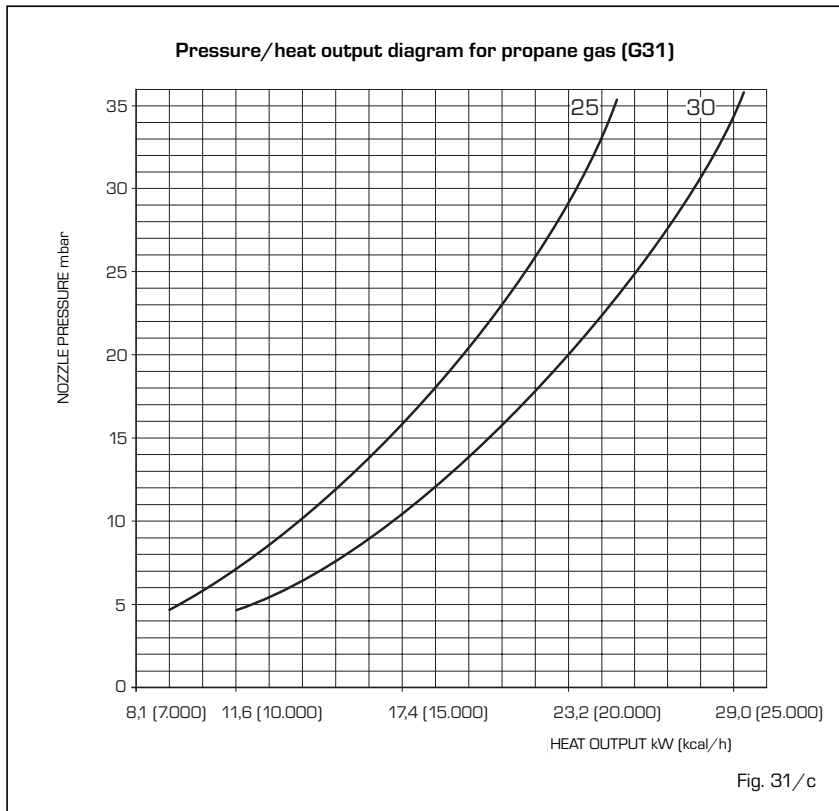
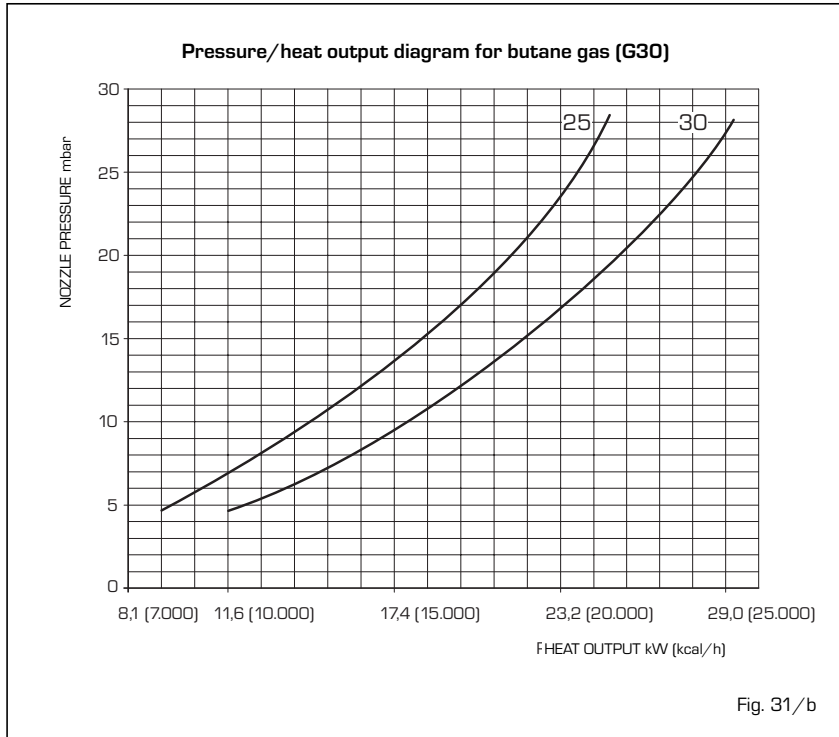

pre-setting data on the data tag.

NOTE: After assembly the sealing capacity of all the gas connections must be tested, using soapy water and special products, and avoiding the use of naked flames. The conversion must be carried out only by authorised personnel.

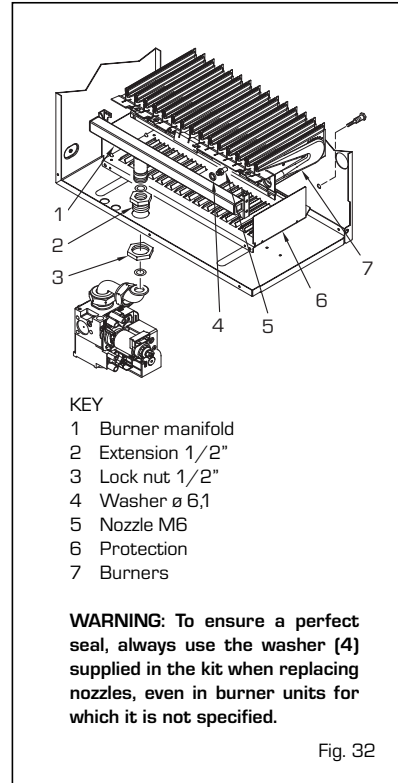

4.5 DISASSEMBLY OF EXPANSION VESSEL

To disassemble the expansion vessel proceed in the following way:

- Make sure that the boiler has been emptied of water
- Unscrew the union that connects the expansion vessel and the screws that release it from its bracket.

Before refilling the system, make sure that the expansion vessel is pre-loaded to a pressure of 0.8 ± 1 bar.

4.6 REMOVAL THE OUTER CASING

For easy maintenance of the boiler it is possible to completely dismantle the casing following these simple instructions (fig. 33):

- Pull the front panel (5) fixed with pin clutches forward.
- Unscrew the two screws that fix the control panel to the shell.
- Remove the side panel (6) by unscrewing the two screws that fix it to the upper bracket (7) and to the support control panel. Push upwards to free it from the notches in the right side.

- Close the gas tap
- Undo the burner group
- Replace the main nozzles (5) supplied in kit, and placing the copper washer (4); to carry out this operation use a \varnothing 7 wrench.
- Insert the bridge of the iMETHANE-GPLi connector of the electronic panel onto the iGPLi position (4 fig. 22).

- For the setting of the values of the maximum gas pressure and the minimum follow the indications as specified in point 4.2. Once the operating pressure changes have been carried out seal the regulators.
- The supply pressure must never be greater than 50 mbar.
- Once the operations have been finished cover, with the label supplied, the gas

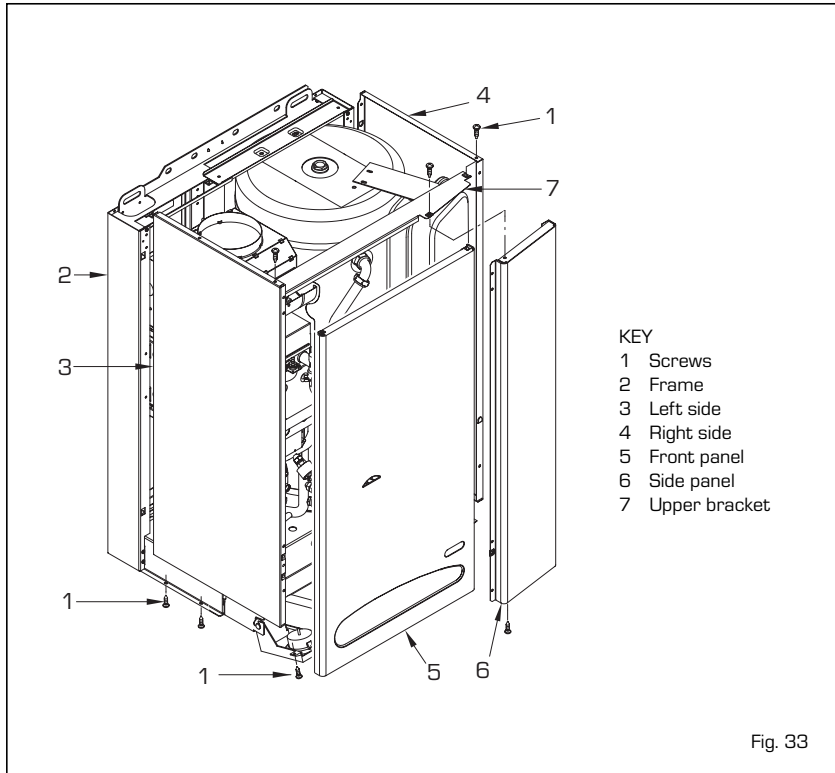

Fig. 33

- Unscrew the four lower screws that fix the sides to the support control panel and the two screws that fix it to the upper bracket (7). Push the sides (3) and (4) upwards freeing them from the notches in the frame (2).

4.7 CLEANING AND MAINTENANCE

Carry out the cleaning of the generator in the following way:

- Remove the electricity supply to the boiler and close the gas supply tap.
- Disassembly the casing as described in point 4.6.
- Disassembly the burner - gas manifold group (fig. 32).
- Clean direct a stream of air towards the inner part of the burner to blow out any dust that has accumulated.

- Then clean the heat exchanger removing dust and combustion deposits.
- In cleaning the heat exchanger and that of the burner, chemical products or steel brushes must never be used.
- Make sure that the top perforated part of the burners is free of encrustations.
- During the assembly and disassembly of the burner it is recommended that attention be paid to the ignition and detection electrodes.
- Reassemble the parts removed from the boiler, observing the succession of the phases.
- Check the functioning of the main burner.
- After the assembly all the gas connections must be checked for the seal, using soapy water or specific products, avoiding the use of naked flames.

Preventive maintenance and checking of efficient operation of equipment and

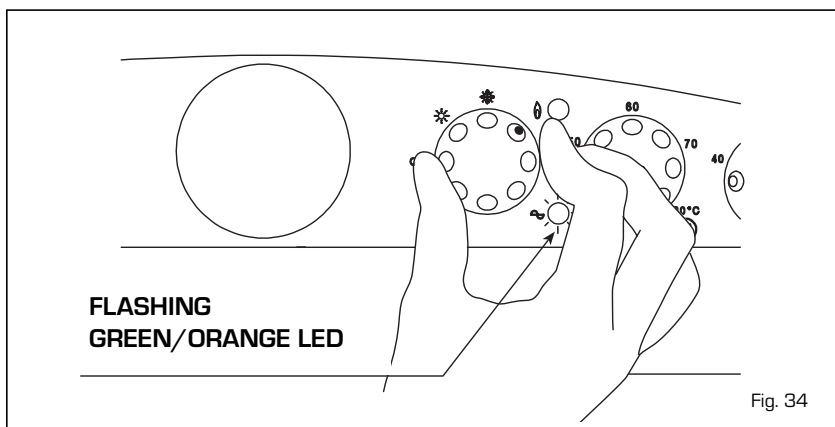

Fig. 34

safety devices must be carried out exclusively by authorized technical personnel.

4.7.1 Chimney sweep function

To carry out the verification of combustion in the boiler turn the selector and stop on the position (0) until the green/ orange led starts to flash intermittently (fig. 34).

From that moment the boiler will start functioning in heating mode at the maximum power [20,000 - 25,000 kcal/ h], with switching off at 80°C and restarting at 70°C. Before activating the chimney sweep function make sure that the radiator valves or eventual zone valves are open.

The test may be carried out also during hot-water service functioning.

To do so it is enough, after having activated the chimney sweep function, to take some hot water from one or more cocks. Even in this condition the boiler functions at the maximum temperature always with the primary controlled between 80°C and 70°C. During the entire duration of the testing the hot water taps must remain open.

After verifying the combustion the boiler should be switched off by placing the selector on the OFF position; then return the selector to the desired function.

ATTENTION:

After about 15 minutes, or once the hot water request has been fulfilled, the chimney sweep function automatically deactivates.

4.8 FAULT FINDING

The burner does not light up and the circulator functions.

- Check that the water pressure is on a value of 1 - 1.2 bar.
- The water pressure switch is faulty and needs to be replaced.

The main burner does not start either in the hot water or heating drawing.

- Check and eventually replace the water pressure switch.
- If the smoke stat has intercepted, then reinstate it.
- Check that the coils of the gas valve are receiving electricity, check the functioning and eventually replace it.
- Check the functioning of the limit stat of the smoke pressure switch (vers. "BF").
- The fan works but at a reduced number of turns and not activating the smoke manostat, it is necessary to replace it (vers. "BF").
- Replace the electronic board.

The boiler starts up but after 10 seconds it blocks.

- Check that in the electrical connection the positions of phase and neutral have been respected.
- The ignition/ detection electrode is faulty;

- it must be replaced.
- Replace the electronic board.

The gas valve does not modulate in heating and hot water phases.

- The sensor is interrupted, it needs to be replaced.
- The winding of the modulator is interrupted.
- Check that the electricity to the modulator is in compliance with the specifications.
- Substitute the panel as it is faulty.

In the exchanger of the boiler there are noises and sparking.

- Check that the circulator is not blocked, eventually unblock it.
- Remove impurities and sediment that have accumulated around the rotor of the circulator.
- The circulator is burnt or the number of turns is less than that foreseen; it must be replaced.
- Check that the power to the boiler is adequate to the actual necessities of the heating system.

The safety valve of the boiler frequently intercepts.

- Check that the filling cock is closed. If it does not close perfectly then replace it.
- Check that the filling pressure when the system is cold is not too high, keep to the given values.
- Check whether the safety valve is calibrated, eventually replace it.
- Check whether the capacity of the tank is enough to hold the quantity of water of the system.
- Check the pre-loading pressure of the expansion vessel.
- Replace the expansion vessel if faulty.

The radiators do not heat up in winter.

- The rotary switch is in the summer position, put it on the winter position.
- The room stat is regulated too low or needs to be replaced as it is faulty.
- The electrical connections of the room stat are not correct.

The principal burner burns badly: flames too high, yellow flames.

- Check that the gas pressure to the burner is normal.

- Check that the burners are clean.
- Check that the coaxial duct is correctly installed (vers. "BF").

Smell of combusted gas

- Check that the boiler is perfectly clean.
- Check that the suction is sufficient.
- Check that there is not an excessive.

The boiler is functioning but the temperature is not increasing.

- Check that the consumption of gas is not below that foreseen.
- Check that the boiler is clean.
- Check that the boiler is proportional to the system.

In the "BF" versions on request for hot water or heating the fan does not start.

- Make sure that the smoke pressure switch is functioning and that the relative contact is in rest conditions.
- Check and if necessary remove impurities or condensation from the connecting tubes of the smoke pressure switch.
- It is necessary to replace the smoke pressure switch.
- Replace the electronic board.



USER INSTRUCTIONS

IT

ES

PT

GB

RO

RUS



WARNINGS

- In case of fault and/or incorrect equipment operation, deactivate it, without making any repairs or taking any direct action. Contact the authorised technical staff.
- The installation of the boiler and any servicing or maintenance job must be carried out by qualified personnel. Under no circumstances, the devices sealed by the manufacturer can be tampered with.
- It is absolutely prohibited to block the intake grilles and the aeration opening of the room where the equipment is installed.

LIGHTING AND OPERATION

BOILER IGNITION (fig. 1)



Open the gas valve and light the appliance by turning the rotary switch to summer position . The green led indicates that electricity is being supplied to the appliance.

- With the rotary switch in the summer position , the boiler will start-up upon demand for domestic hot water, and run at full power to reach the selected temperature. The gas feeding pressure will then automatically vary to ensure that the required temperature is kept constant.
- With the rotary switch in the winter position , once the boiler has reached the value set on the heating potentiometer, it will start to modulate in automatically in

order to supply the required power output to the system.

The operation of the boiler will be stopped through the intervention of the thermostat or timer.

TEMPERATURES ADJUSTMENT (fig. 2)

- The D.H.W. temperature can be adjusted by turning the knob of the D.H.W. potentiometer  which has a range of between 40 to 60°C (fig. 2).
- The C.H. temperature can be adjusted by turning the knob of the C.H. potentiometer  which has a range of between 40 to 80°C. To ensure optimal boiler efficiency at all times, we recommend not to drop below a minimum working temperature of 50°C.

ciency at all times, we recommend not to drop below a minimum working temperature of 50°C.

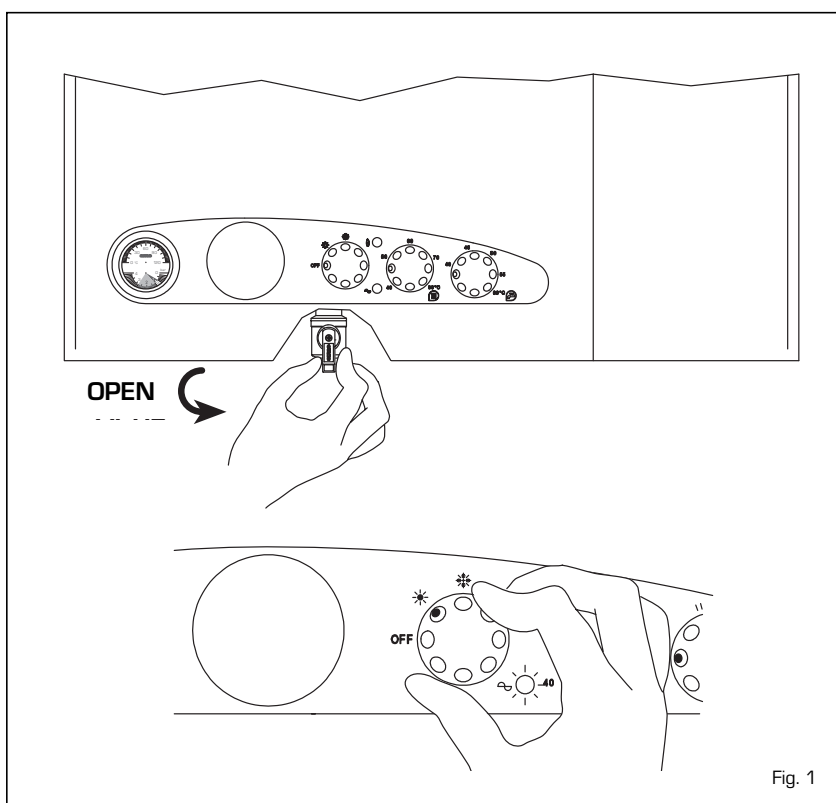
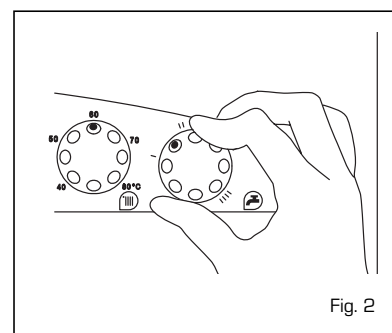

TURNING THE BOILER OFF (fig. 1)

To turn the boiler off place the rotary switch on the **OFF** position. If the boiler is not going to be used for a lengthy period it is advised to turn off the electricity supply, close the gas cock, and if low temperatures are foreseen, empty the boiler and the hydraulic system to avoid breakage in the tubes due to the freezing of the water.

GAS CONVERSION

Should it be necessary to convert the appliance to a different gas from the one for which the boiler has been equipped, approach the technical staff.

CLEANING AND MAINTENANCE

Preventive maintenance and checking of the efficient operation of the equipment and safety devices must be carried out exclusively by the authorized technical staff. The boiler is supplied with an electric cable. Should this require replacement, contact exclusively an authorised technical staff.

FAULT FINDING

- **Ignition failure/safety stat interception** (fig. 3)

If the burner fails to start the red led that signals blockage will light up. To attempt starting it again, the rotary switch must be turned to the position (OFF) and released soon after, returning to the summer (☀) or winter (❄) position.

If the failure should occur again, call the authorised technical staff to check the boiler.

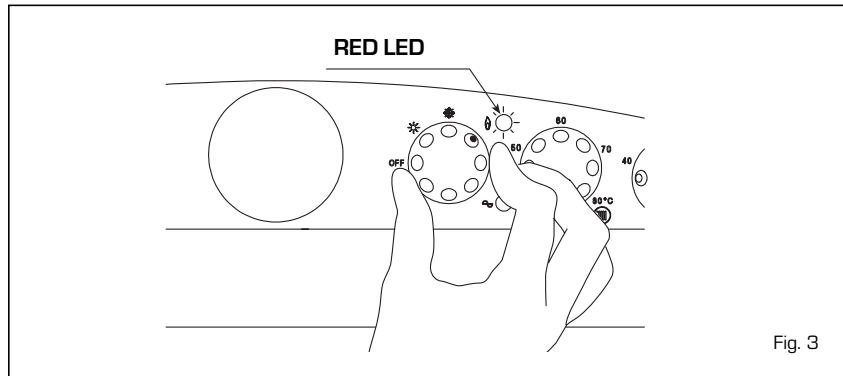

Fig. 3

- **Insufficient water pressure** (fig. 4)

In case the index of the thermomanometer is below scale of the blue colour (2) the boiler is not functioning and the orange bicolour detector is flashing. To restore functioning act on the filling cock taking the index of the manometer within the scale of the blue colour (2).

ONCE FILLED CLOSE THE FILLING TAP. The blue coloured scale (1) shows the working field with heating system functioning.

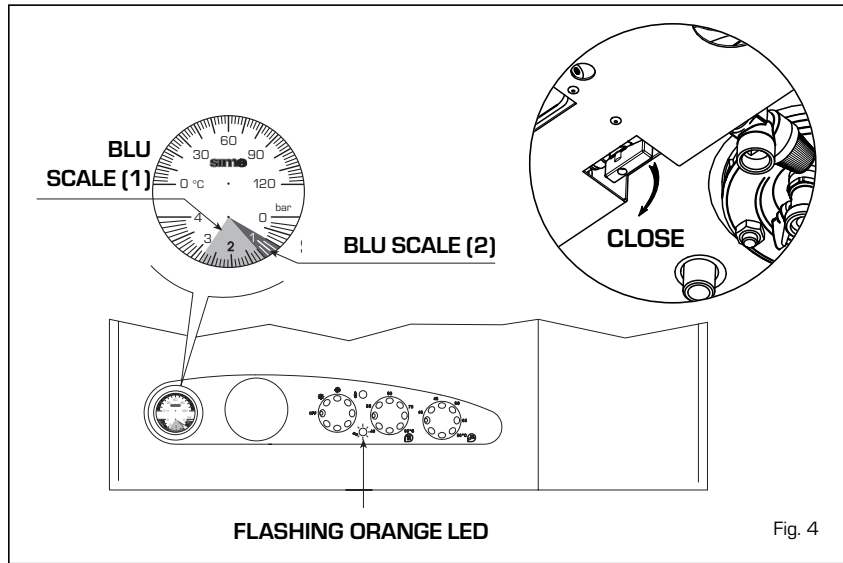

Fig. 4

- **Other faults** (fig. 5)

In the "25/60 BF - 30/60 BF" versions in case the green bicolour detector (fan/pressure switch), deactivate the boiler and call the authorised technical staff for assistance. In case the orange bicolour detector lights up (heating sensor SM failure), deactivate the boiler and call the authorised technical staff for assistance.

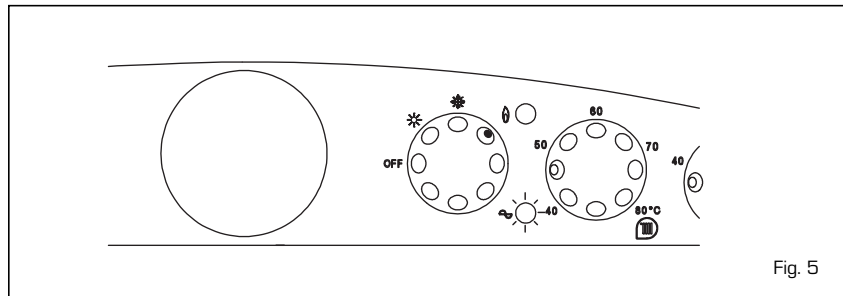

Fig. 5

- **Smoke safety device vers. "25/60"** (fig. 6)

If the green bicolour detector is flashing (fig. 5) the boiler is not functioning. To restore functioning reinstate the thermostat button.

If the failure should occur again, call the authorised technical staff for assistance.

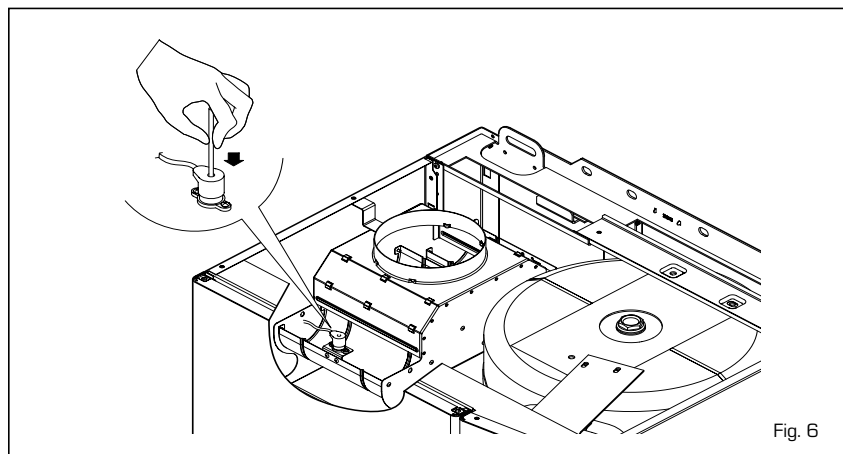

Fig. 6

TIME PROGRAMMER (optional)

With the selector in the "AUTO" position, the boiler operation is regulated according to the temperatures set for the programmed time periods.

During start-up, the second selector must be in the "RUN" position. Programming:

- Setting the time (fig. 7)

Move the selector to "☺". To change the hour on the display, press the "h" button, to change the minutes, press the "m" button.

To set the day, press button "1...7" until the arrow points to the correct day (1 = Monday 7 = Sunday).

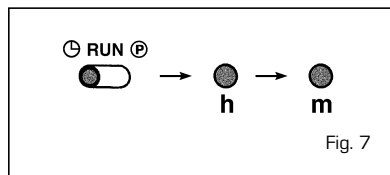

- Setting the programme (fig. 8)

The programmer has 8 start-up programmes and 8 shutdown options.

To make programming easier, 3 start-up and 3 shutdown programmes have already been set up for each day of the week, as follows:

Programa	Hora de encendido	Hora de apagado
1	06,00	-
2	-	09,00
3	12,00	-
4	-	14,00
5	18,00	-
6	-	22,00

NOTE: Programmes from 7 to 16 are not pre-set.

To select programmes other than those pre-set, move the selector to the "P" position: "0:00 1" will appear on the display: the first three figures indicate the hour and minutes, the fourth figure is the number of the programme.

Programmes with odd numbers are switch-on times (daytime temperature) and are indicated on the display by a light bulb symbol. Programmes with even numbers indicate the temperature reduction (night).

Use button "1...7" to select the day of the week (from 1 to 7), or the period (1 ÷ 5, 6 - 7; 1 ÷ 6; or every day if the programme has to be repeated every day of the week). Set the hour and minutes using buttons "h" and "m".

The operation is memorized by pressing button "P"

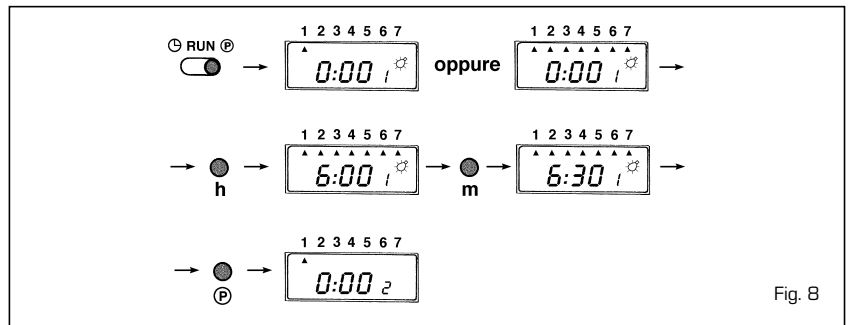

The display then changes to the further programme. Repeat the same operations to set the successive programmes. At the end of the programming. Move the selector to the "RUN" position.

appear on the clock display together with an indication of the incorrect programme. To cancel all the programmes, move the selector to the "P" position and press buttons (3) and (5) simultaneously.

- Cancelling one or more programmes (fig. 9)

The programmed switch-on time and switch-off time must be cancelled for each individual programme by moving selector (2) to the "P" position.

Select the required programme with button (3), press button (4) to cancel the settings for that day (the triangular day indicator should disappear).

If a part of the programme is cancelled, when selector (2) is returned to the "RUN" position, an error message will

- Setting the "SKIP" function (fig 9)

The SKIP function defused the programmes when going out for the day, during which no heating is required.

To start this function, press button (7); the button is only active when selector (2) is in the "RUN" position.

Once selected, the SKIP function becomes active at 0:00 of the following day and lasts for 24 hours.

Once activated, it cannot be defused. Consequently the normal programme will only be resumed after 24 hours.

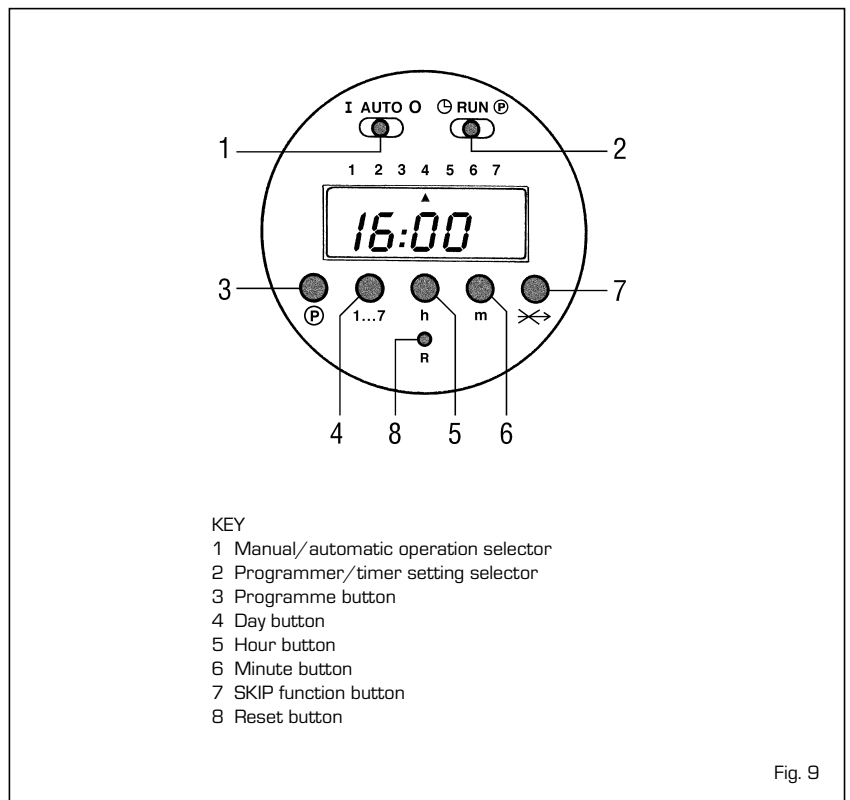

KEY

- 1 Manual/automatic operation selector
- 2 Programmer/timer setting selector
- 3 Programme button
- 4 Day button
- 5 Hour button
- 6 Minute button
- 7 SKIP function button
- 8 Reset button