

INSTALLER INSTRUCTIONS

CONTENTS

1	DESCRIPTION OF THE BOILER	pag.	41
2	INSTALLATION	pag.	43
3	CHARACTERISTICS	pag.	45
4	USE AND MAINTENANCE	pag.	47

IMPORTANT

When carrying out commissioning of the boiler, you are highly recommended to perform the following checks:

- Make sure that there are no liquids or inflammable materials in the immediate vicinity of the boiler.
- Make sure that the electrical connections have been made correctly and that the earth wire is connected to a good earthing system.
- Open the gas tap and check the soundness of the connections, including that of the burner.
- Make sure that the boiler is set for operation for the type of gas supplied.
- Check that the flue pipe for the outlet of the products of the combustion is unobstructed.
- Make sure that any shutoff valves are open.
- Make sure that the system is charged with water and is thoroughly vented.
- Check that the circulating pump is not locked.
- Purge the system, bleeding off the air present in the gas pipe by operating the pressure relief valve on the gas valve inlet.

FONDERIE SIME S.p.A. of Via Garbo 27 - Legnago (VR) - Italy declares that its hot water boilers, which bear the CE mark under Gas Directive 90/396/CEE and are fitted with a safety thermostat calibrated to a maximum of 110°C, **are not subject** to application of PED Directive 97/23/CEE as they meet the requirements of article 1 paragraph 3.6 of the Directive.

1 DESCRIPTION OF THE BOILER

1.1 INTRODUCTION

The new series of "RX" gas-fired heating boilers has been designed and manufactured to ensure maximum user-friendliness and to ease both the installation and the maintenance operations for the installer.

They comply with the european directi-

ves 90/396/CEE, 89/336/CEE, 92/42/CEE, 73/23/CEE and the european specification EN 297.

These appliances can be fired by natural gas (methane) and butane gas (G30) or propane gas (G31).

This manual contains the instructions for the following boiler models:

- "RX 19÷55 CE IONO" with electro-

nic ignition and flame ionization

- "RX 19-26 PVA CE IONO" with pump, expansion vessel, electronic ignition and flame ionization.

The instructions given in this manual are provided to ensure proper installation and perfect operation of the appliance.

1.2 DIMENSIONS

1.2.1 "RX 19-26" versions

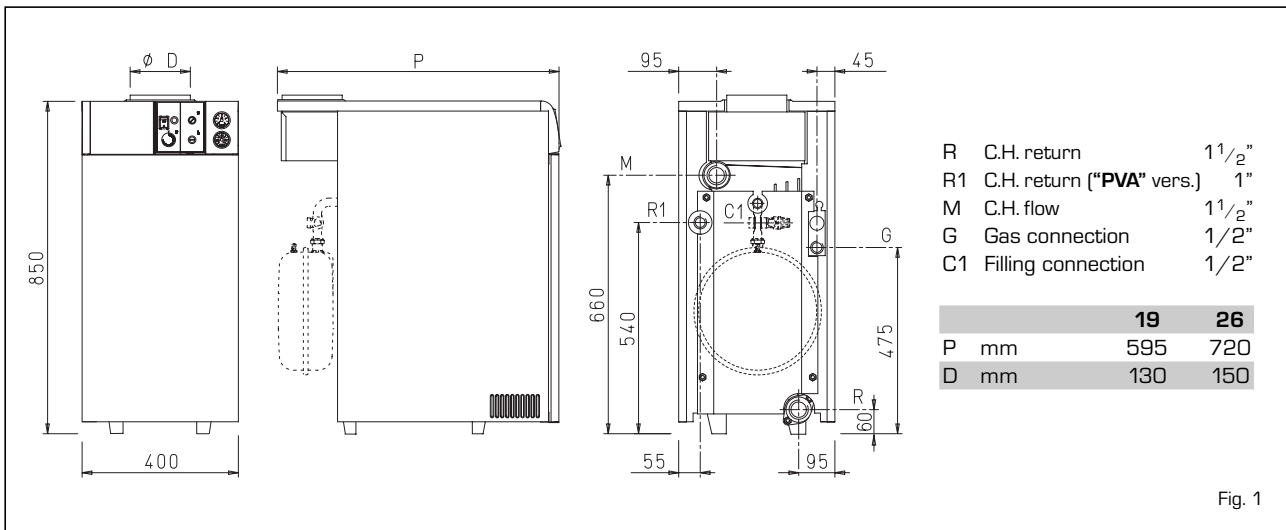

1.2.2 Versión "RX 37÷55"

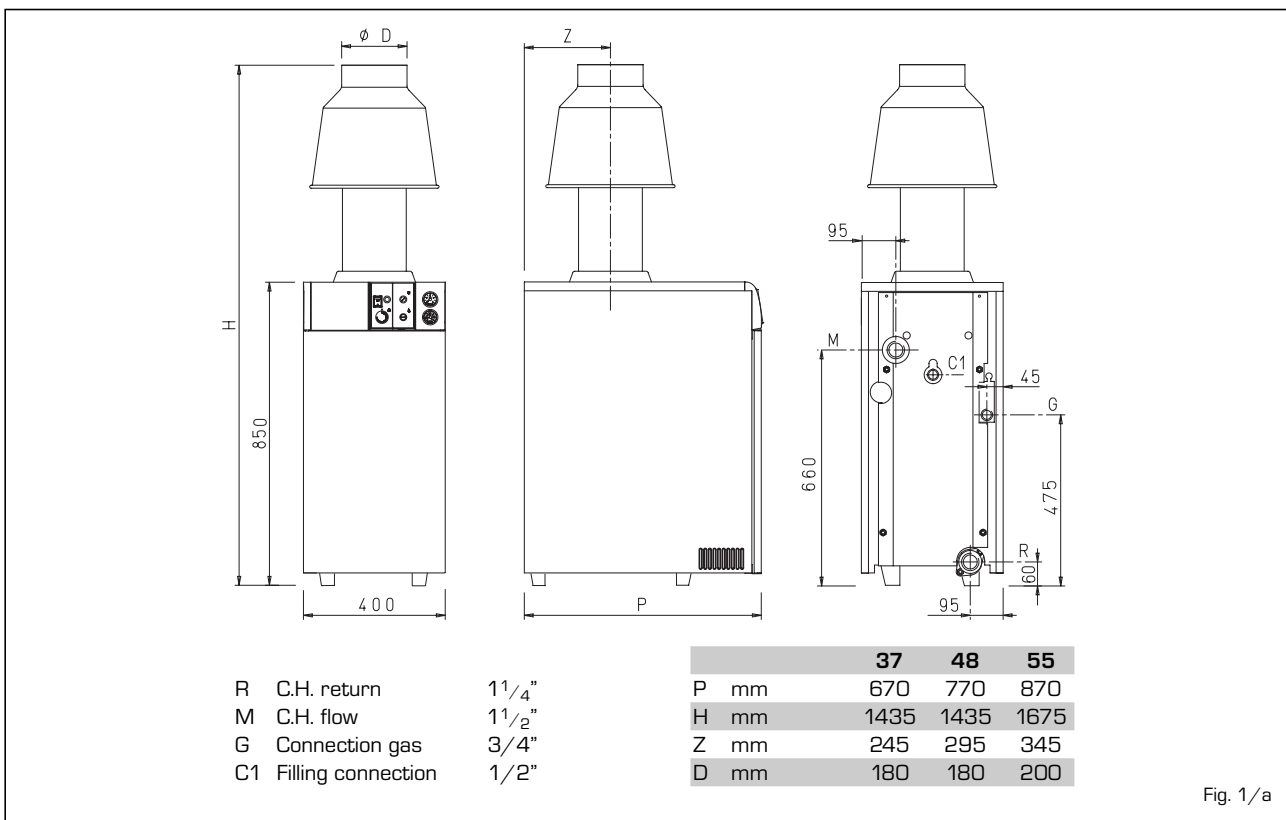

IT

ES

PT

GB

GR

RO

RUS

SCG

1.3 TECHNICAL FEATURES

		19	26	37	48	55
Heat output	kW	22,0	30,5	39,1	48,8	60,7
	kcal/h	18.900	26.200	33.600	42.000	52.200
Heat input	kW	25,0	34,8	44,8	55,0	69,2
	kcal/h	21.500	29.900	38.500	47.300	59.500
Number of sections		3	4	5	6	7
Water content	l	10	13	16	19	22
Power consumption	W	16-100*	16-100*	16	16	16
Maximum water head	bar	4	4	4	4	4
Maximum temperature	°C	95	95	95	95	95
Expansion vessel						
Water content/Preloading pressure	l/bar	8/1	10/1	-	-	-
Smokes temperature	°C	119	118	110	130	141
Smokes flow	gr/s	24,7	34,7	52,2	53,1	59,2
Category		II2H3+	II2H3+	II2H3+	II2H3+	II2H3+
Type		B11BS	B11BS	B11BS	B11BS	B11BS
Weight	kg	101-113*	126-138*	150	176	202
Main burner nozzles						
Quantity	n°	2	2	3	3	3
Methane/G30 - G31	ø mm	3,15/1,80	3,65/2,10	3,40/1,95	3,90/2,20	4,05/2,45
Gas consumption **						
Methane	m ³ /h	2,64	3,68	4,73	5,82	7,32
Butane (G30)/Propane (G31)	kg/h	1,97/1,94	2,74/2,69	3,53/3,47	4,34/4,27	5,45/5,37
Burner gas pressure						
Methane	mbar	9,8	9,6	9,6	9,1	11,5
Butane (G30)/Propane (G31)	mbar	28/35	28/35	28/35	28/35	28/35
Gas supply pressure						
Methane	mbar	20	20	20	20	20
Butane (G30)/Propane (G31)	mbar	30/37	30/37	30/37	30/37	30/37

* "PVA" vers.

** The gas consumptions refer to the calorific value at standard conditions at 15°C - 1013 mbar

1.4 MAIN COMPONENTS

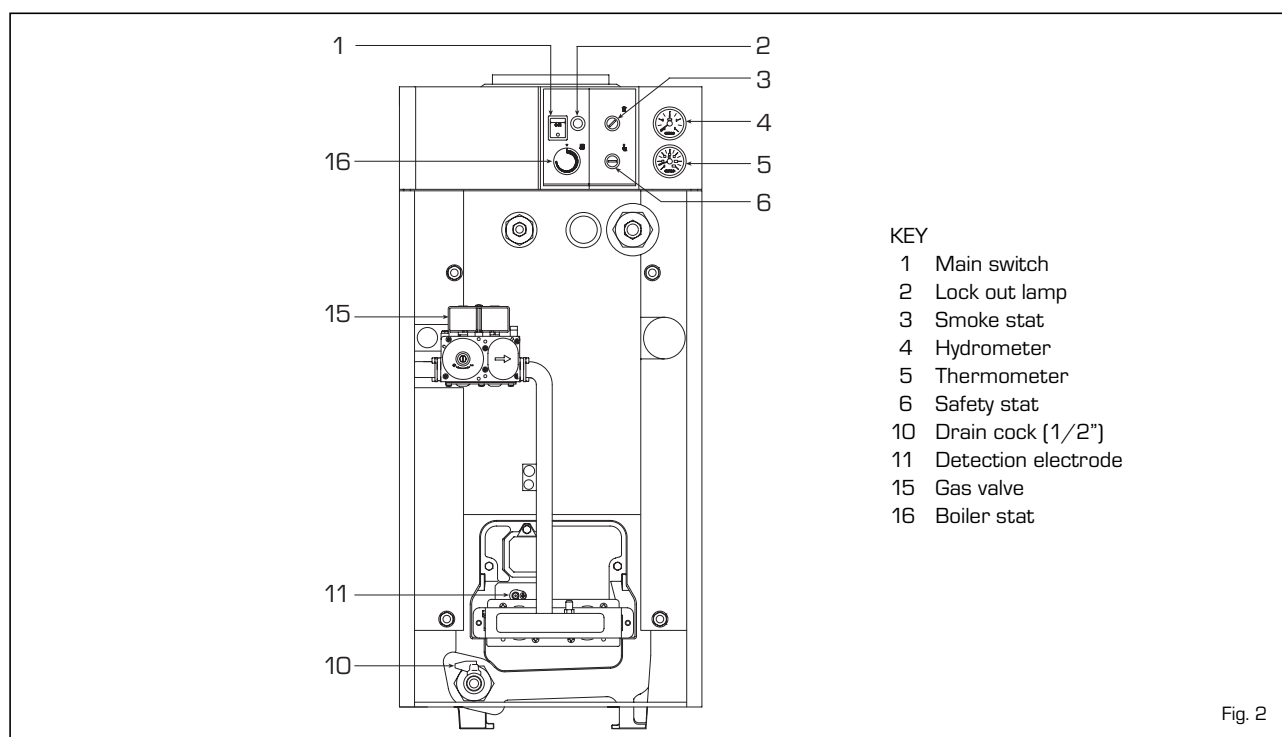

Fig. 2

1.5 BOILER CIRCUIT LOAD LOSS

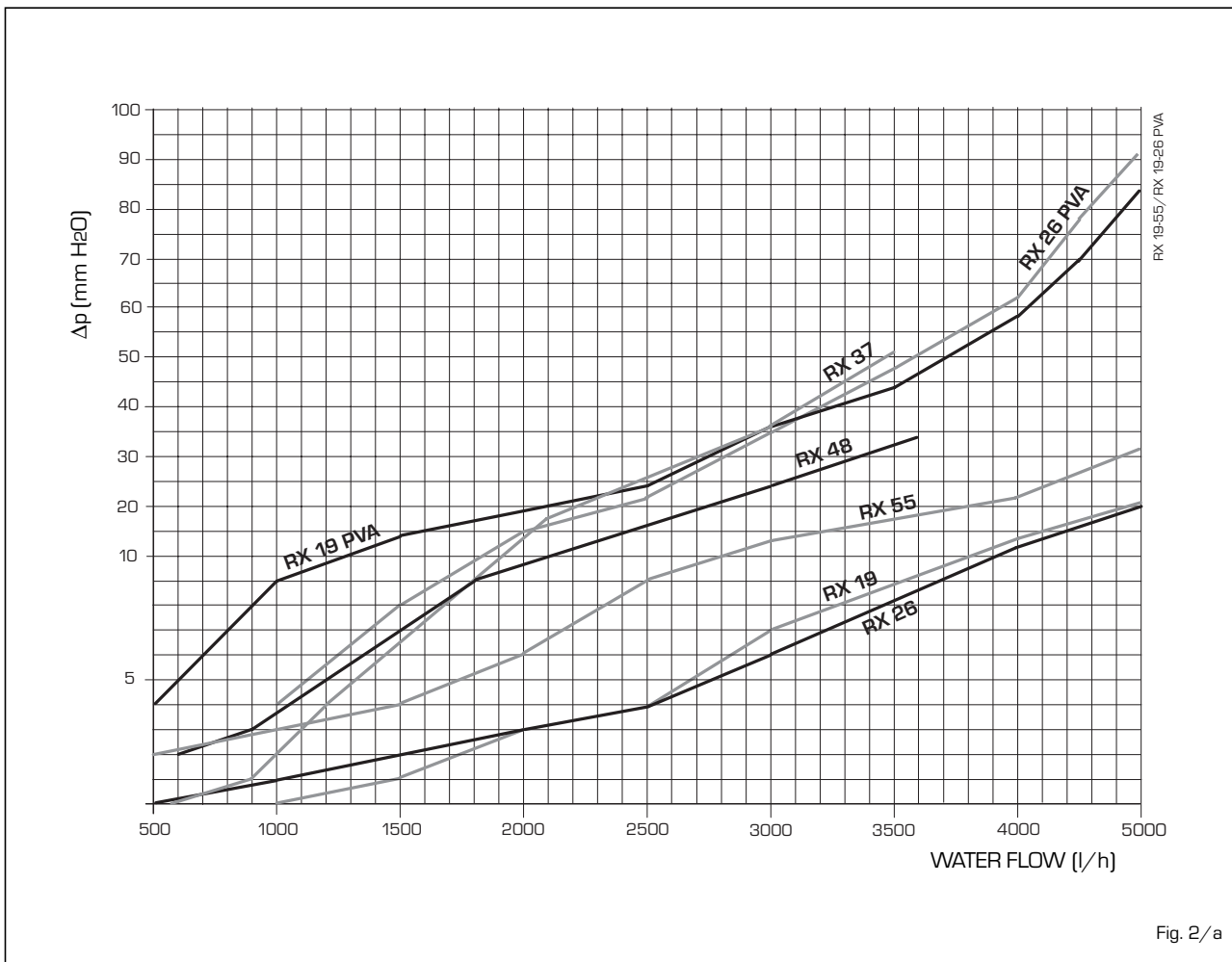

Fig. 2/a

2 INSTALLATION

The boiler should be installed in a fixed location and shall be carried out only by specialized and qualified firms in compliance with all instructions contained in this manual.

2.1 BOILER ROOM AND VENTILATION

There are no particular regulations to follow with reference to the boiler room because "RX 19-26" boilers, which do not exceed the 35 kW limit, can be installed in rooms that are sufficiently ventilated.

The rooms where the gas-fired systems are installed must receive at least the quantity of air necessary for the normal combustion of the gas used

by the various installations.

Therefore, to ensure the air circulation in the rooms, it is necessary to make some holes in the walls.

These holes must have the following characteristics:

- Have a total free surface of minimum 6 cm² for each kW of thermal capacity, for a minimum of 100 cm².
- They must be located as close as possible to floor level, not prone to obstruction and protected by a grid which does not reduce the effective section required for the passage of air.

The "RX 37÷55" models with a capacity exceeding 35 kW shall instead be installed in a boiler room that meets the existing safety regulations for

network gas-fired heating systems, where minimum distances must be observed.

2.2 BOILER CONNECTION

Before connecting the boiler circulate some water in the pipes to eliminate any foreign bodies which may prevent the equipment from working properly. When making the hydraulic connections, follow the instructions of fig. 1 carefully.

Connections shall be easily disconnected by means of unions with revolving fittings. It is always advisable to mount suitable interception gate valves on the C.H. flow and C.H. return plant pipes. The gas connection must be made

using seamless steel pipe (Mannesmann type), galvanized and with threaded joints provided with gaskets, excluding three-piece connections, except for initial and end connections. Where the piping has to pass through walls, a suitable insulating sleeve must be provided.

When sizing gas piping, from the meter to the boiler, take into account both the volume flow rates (consumption) in m³/h and the relative density of the gas in question.

The sections of the piping making up the system must be such as to guarantee a supply of gas sufficient to cover the maximum demand, limiting pressure loss between the gas meter and any apparatus being used to not greater than:

- 1.0 mbar for family II gases (natural gas);
- 2.0 mbar for family III gases (butane or propane).

An adhesive data plate is stuck inside the front panel; it contains all the technical data identifying the boiler and the type of gas for which the boiler is arranged.

2.2.1 Filter on the gas pipe

The gas valve is supplied ex factory with an inlet filter; which, however, is not adequate to entrap all the impurities in the gas or in gas main pipes.

To prevent malfunctioning of the valve, or in certain cases even to cut out the safety device with which the valve is equipped, install an adequate filter on the gas pipe.

2.3 CHARACTERISTICS OF FEEDWATER

It is absolutely essential that the water for the central heating system is to be treated in the following cases:

- Very extensive system (with high contents of feedwater).
- Frequent addition of makeup water into the system.
- Should it be necessary to empty the system either partially or totally.

2.4 SYSTEM FILLING

The filling shall be made slowly so that air bubbles are eliminated through the vents. The charge pressure, with the system cold, must be between **1** and **1,2**

bar. The system loading pipe can be connected with the 1/2" coupling on the back header or, on the "PVA" models, on the cross coupling connected to the expansion tank.

2.5 FLUE

A flue for the discharge into the atmosphere of the products of combustion of natural draught plants must have the following characteristics:

- be sealed against the products of combustion, waterproof and insulated;
- be made of materials capable of withstanding normal mechanical stresses, heat and the action of the products of combustion and their condensate;
- be vertical and with no narrowing throughout its whole length;
- be properly insulated to avoid flue gases condensing or cooling, especially if it is placed outside a building or in rooms with no heating;
- be kept at a safe distance from combustible and easily inflammable materials by an air space or any other suitable insulating material;
- have a chamber collecting solid materials and condensates below the mouth of the first flue; this chamber must be at least 500 mm high. Access to this chamber must be ensured through a hole with an airtight metal door;
- its inner section must be round, square or rectangular; if it is square or rectangular, the corners must be round and have a radius of 20 mm minimum; however, hydraulically equivalent sections are also permitted;
- be topped by a chimney pot having its outlet outside the reflux area in order to avoid back pressures which may obstruct the free discharge of

flue gas into the air;

- there must be no mechanical suction equipment at the top of the pipe;
- there must be no overpressure in stacks placed inside or adjacent to inhabited rooms.

2.5.1 Flue connection

Fig. 3 refers to the boiler connection to the flue or to the stack through flue ducts. In making the connection observe the dimensions given and use sealing materials capable of withstanding mechanical stresses and flue heat over time.

At any point of the flue the burnt gas temperature shall not exceed the dew point temperature. Maximum three changes of direction can be made, including the union to the stack/flue.

For changes of direction, use only curved components.

2.6 ELECTRIC CONNECTION

The boiler is equipped with an electric cable with plug and shall be supplied with 230 V - 50 Hz single-phase current through a fuse protected switch having a minimum distance of 3 mm between the pins.

The room thermostat (class II according to EN 60730.1), which should be installed to ensure a good temperature control, must be connected to terminals 1 and 4 after the existing bridge has been removed.

NOTA: Device must be connected to an efficient earthing system. SIME refuses all responsibility for damage to people or things due to non-earthing of the boiler. Always turn off the power supply before doing any work on the electrical panel.

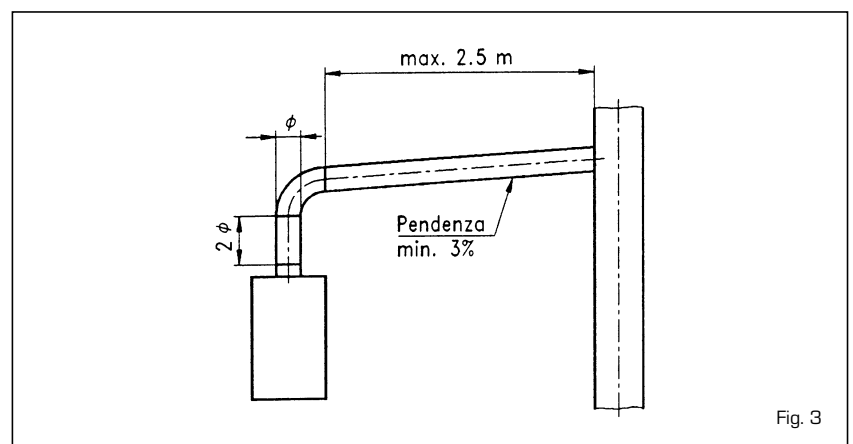

2.6.1 Wiring diagram

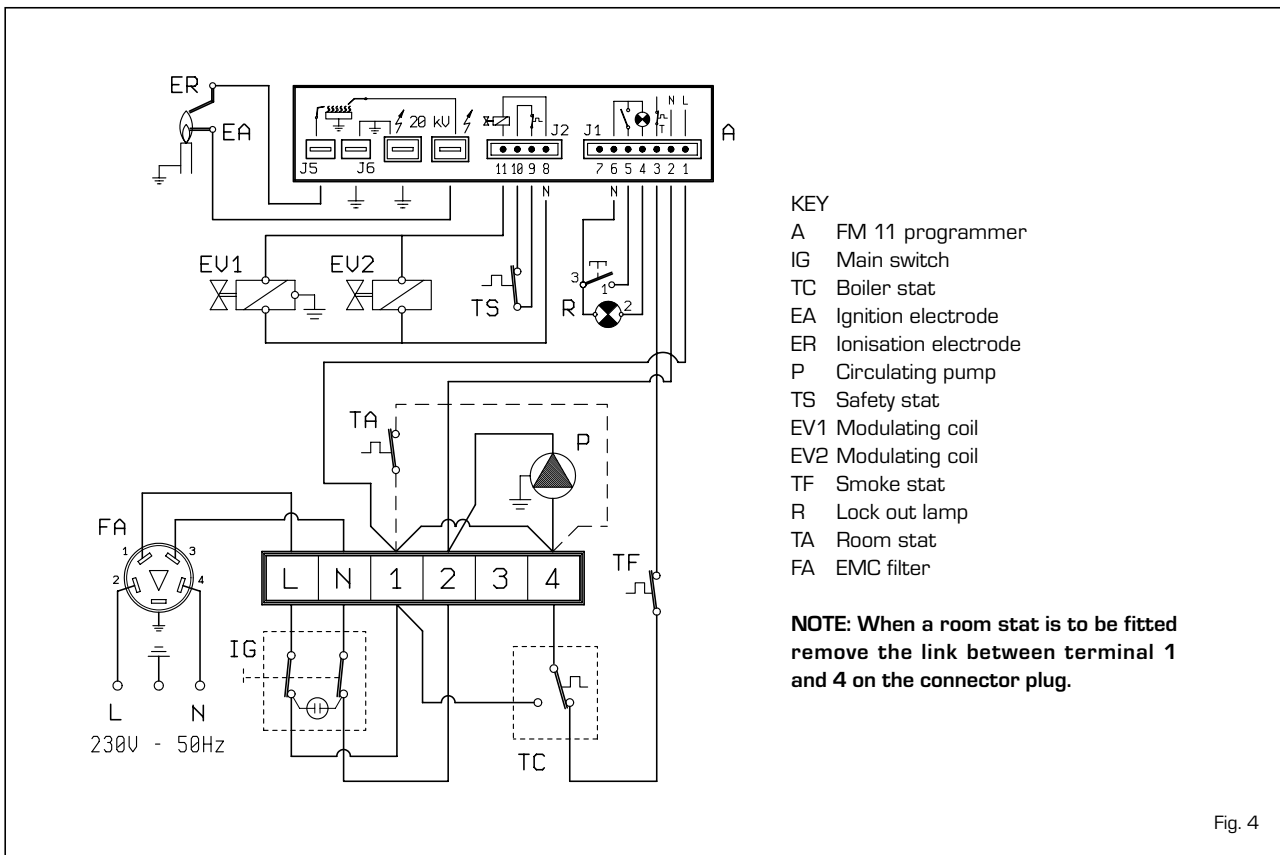

3 CHARACTERISTICS

3.1 ELECTRONIC IGNITION

The boilers are equipped with electronic ignition without pilot flame; they are therefore equipped with an electric control and protection device. An electronic programmer, model Brahma FM 11, controls the ignition and the ionisation by means of two electrodes as shown in fig. 5.

Maximum safety is guaranteed because in case of accidental extinction of the burner the gas flow is stopped within 1 second. A reference mark made on the burner ensures the proper application of the ignition electrode.

3.1.1 Working cycle

Before lighting the boiler check with a voltmeter that the electric connection to the terminal board has been properly made observing the phase and neutral positions of the wiring diagram. Press the main switch on the control

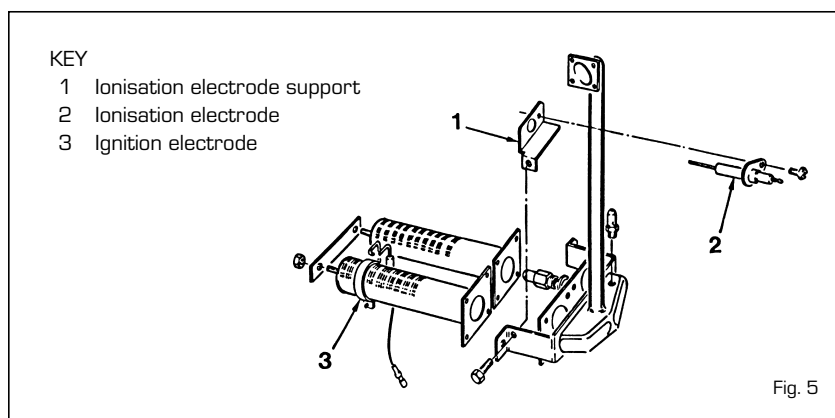

board; the lamp will light if there is power. At this stage the boiler will start to work sending, via the FM 11 programmer, a discharge current to the electrode and, at the same time, opening the gas valve. Normally the burner takes 1 or 2 seconds to light. It may however fail to light, in which case the boiler lock-out lamp will be activated. The main causes maybe:

- No gas supply

The equipment performs regularly sending voltage to the ignition electrode that continues to spark for max. 10 seconds, without detecting the burner starting, then it shuts down.

It may occur at the first starting or when the boiler has not been used for a long period of time and there is

- IT
- ES
- PT
- GB**
- GR
- RO
- RUS
- SCG

air in the pipes. It may occur if the gas cock is closed or if the winding of one of the valve coils is interrupted, thus preventing it from opening.

- There is no spark

In the boiler you will only notice the gas flow to the burner, after 10 seconds it shuts down.

It may be due to the fact that the electrode cable is disconnected or is not properly fixed to the terminal 10; or the equipment transformer is burnt.

- No ionisation

From the time of the starting you can observe the electrode continuous sparking even if the burner is on. After 10 seconds the sparking stops and so does the burner, while the lock-out lamp appears to be on.

It occurs if the phase and neutral position on the terminal board has not been observed. The detection electrode cable is disconnected or the electrode itself is earthed; the electrode is very worn-out and needs replacing.

The sudden lack of voltage causes the immediate shutdown of the burner and when the voltage is restored the boiler will automatically restart.

3.1.2 Ionization circuit

The ionization circuit shall be checked with a normal microammeter, or even better, with a digital microammeter with a 0÷50 μA range. The microammeter terminals shall be electrically connected in series to the ionisation electrode cable. Under standard conditions the value varies from 4÷6 μA . The minimum ionization current value,

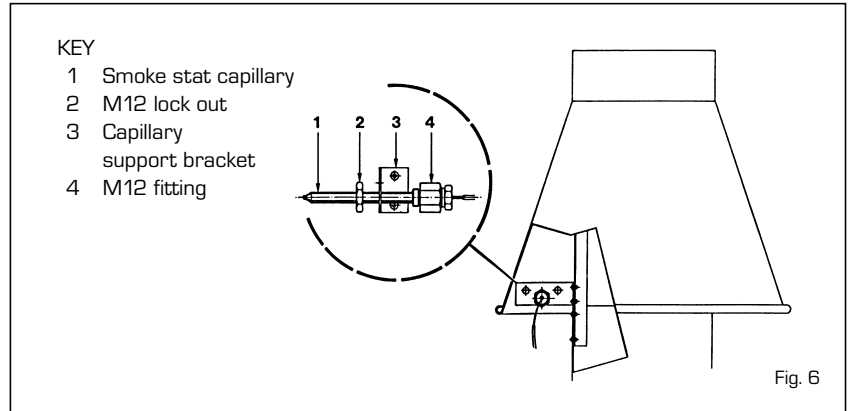

Fig. 6

at which the equipment may shut down, is approximately 1 μA . In this case it will be necessary to check that there is a good electric contact and to check the wear of the electrode tip and of its ceramic protection.

3.2 SMOKE SAFETY DEVICE

The smoke stat provides a protection against the discharge of flue gas into the atmosphere (3 fig. 2). This control device stops the gas valve if the flue gas is discharged into the boiler room in continuous way and in such quantities as to become dangerous.

To start the boiler again, switch off the power, then remove the smoke stat cover and reset the button below.

If the thermostat continues to trip off, it will be necessary to check the flue thoroughly, making all the necessary changes to ensure it works properly.

On the "RX 37÷55" models, the smoke stat capillary on the back of the boiler shall be put into the 12.5 \varnothing hole of the draught-diverter support bracket and fixed to it with the fitting and the M12 lock nut already mounted on the capillary (fig. 6).

3.3 SAFETY STAT

In case the boiler temperature exceeds 95°C the safety stat (6 fig. 2), will extinguish the pilot burner thus shutting off the gas flow to the pilot and main burner. "RX 19-26" models are equipped with safety stat with automatic resetting, and "RX 37÷55" with manual resetting. Should the stat with manual resetting trip off, it will be necessary to unscrew the cover and reset the button below for the pilot burner to restart.

3.4 CIRCULATING PUMP PERFORMANCE CURVES

The "RX PVA" boilers can be equipped with either EURAMO NYL 40/25 or GRUNDFOS UPS 25/50 circulating pumps. Both have a built-in speed selector for adjusting head and capacity. Head and capacity performance curves of the standard circulating pump, at different speeds, are given in fig. 7-8.

NOTE: Before starting the boiler check that the circulating pump is not locked.

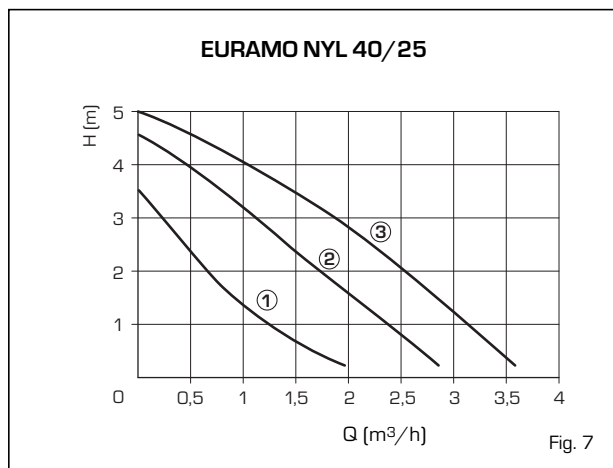

Fig. 7

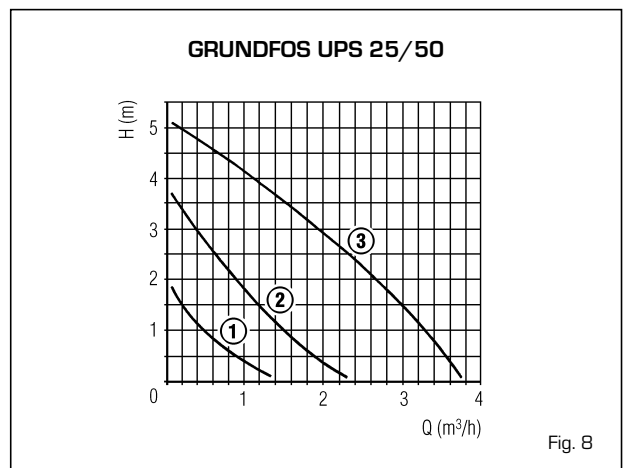

Fig. 8

4 USE AND MAINTENANCE

4.1 ADJUSTING GAS VALVE "19-26" VERSIONS

Standard "RX 19-26" boilers with electronic ignition feature a SIT 830 TANDEM gas valve (fig. 9). When the boiler is ignited for the first time, it is always better to purge the pipe through the pressure tap [3]. Remove the plug on the pressure regulator [4] to adjust the main burner gas pressure.

The regulation is made by rotating the screw under the plug: rotate the screw clockwise to increase the pressure, anticlockwise to reduce it. The valve can control a "soft" ignition of the boiler through the screw [1]. Rotate the screw anticlockwise to increase the burner "soft" ignition pressure (STEP), clockwise to reduce it. The optimum "soft" ignition values of the burner depend on the type of gas:

- Methane 3 - 4 mbar
- Butane 6 - 7 mbar
- Propane 6 - 7 mbar

4.2 ADJUSTING GAS VALVE "RX 37÷55" VERSIONS

The electronically ignited "RX 37÷55" boilers are equipped with the HONEYWELL VR4605C gas valve (fig.10). When igniting the boiler for the first time, it is always advisable to purge the pipe by opening the inlet pressure tap [3]. To adjust gas pressure to the main burner remove the plug on the pressure regulator [5].

Use a screwdriver to regulate the screw under the plug: to increase pressure screw clockwise, to reduce it screw counterclockwise.

4.3 ADJUSTING THE GAS PRESSURE TO BURNERS

Pressure calibration and gas input are carried out by the manufacturer.

During installation of the equipment, feed pressure might be different from standard values.

It is therefore necessary to check pressure and gas input when igniting the boiler for the first time.

This test should be performed with the boiler in full operation (obviously no other gas appliances should be working at the same time). Read the gas meter twice every 6 minutes. Multiply the consumption by ten to calculate the consumption per hour.

If this value does not correspond to the one in point 1.3, turn the screw of the

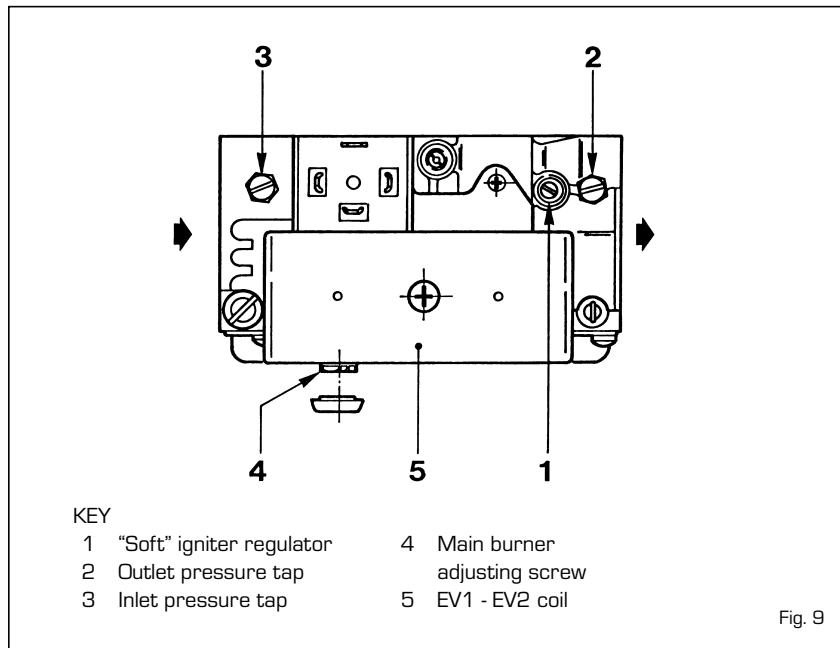

Fig. 9

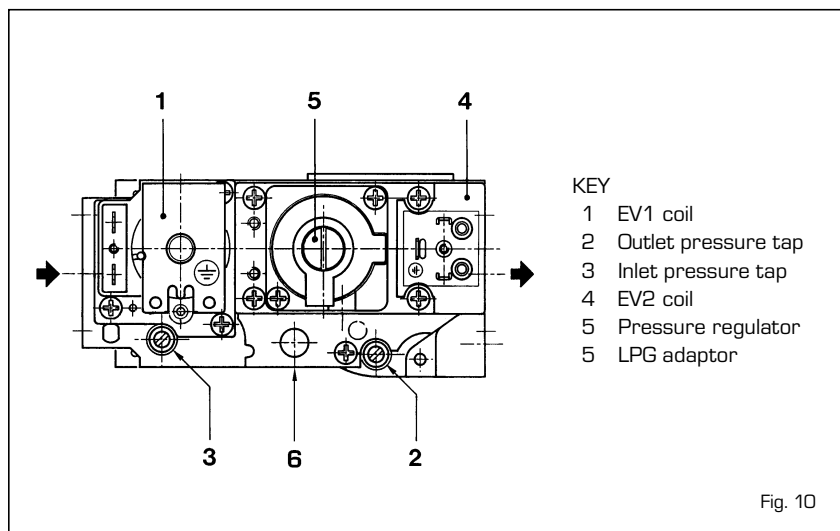

Fig. 10

pressure regulator on the valve until the exact value is obtained. Screw slowly and gradually. Read the gas meter at least thirty seconds after regulating the pressure.

4.4 GAS CONVERSION

A kit is supplied complete with the necessary change-over materials for operation with butane gas (G30) or propane gas (G31). Operate in the following manner for changing over from one gas to another:

- Replace the main nozzles and pilot nozzle supplied in a kit.
- Remove the plug on pressure regulator and tighten the adjusting screw [4 fig. 9 - 5 fig. 10].
- Apply the adaptor onto the gas valve

[6 fig. 10].

- Set valve input pressure at 30/37 mbar according to the type of gas by acting on the outer pressure reducer.
- When the working pressures have been adjusted, reseal the regulators.
- After have ultimated the conversion of the boiler, please stick onto the casing panel the plate showing the relevant feeding gas which is included into the kit.

NOTE: After assembling all the gas connections, a test for gas tightness must be carried out using soapy water or special products. Do not use naked flames. The conversion to different gas must be carried out exclusively by authorized technical personnel.



IT

ES

PT

GB

GR

RO

RUS

SCG

4.5 REMOVING THE CASING

It is possible to completely disassemble the shell for an easy maintenance of the boiler following these simple instructions:

- Remove the boiler top which is fixed with pressure plugs.
- Remove the panelboard.
- To remove the door, unscrew completely the screw fixing the top hinge and lift the door, removing it from the fixed plug of the bottom hinge.
- Remove front and back panels by loosening the four nuts which fix them to the panels side.
- Remove the sides.

4.6 CLEANING AND MAINTENANCE

When the heating is turned off at the end of the season, it is compulsory to check the boiler and clean it as follows:

- Take off the boiler top.
- Remove the smoke chamber cleaning plate by unscrewing the fastening screws in the "RX 19-26" boilers.
- Remove the smoke chamber completely unscrewing the two nuts from the back side and the nut from the front side of "RX 37÷55" boilers.
- Extract the burner assembly by unscrewing the four screws which fix it to the valve flange.
- With the appropriate brush, reach down to the rows of plugs of the cast iron exchanger from the top and scrape off any scale with vertical movements.
- Remove the burners from the nozzle

holder header and throw a jet of air inside them so that any dust can be removed. Make sure that the top drilled part of the burners has no scale left.

- When disassembling and reassembling the burners be careful not to force any delicate parts, such as the thermocouple drill or the ignition unit.
- Scrape off any scale from the boiler bottom and reassemble all the parts checking the position of the gaskets.
- Check the stack making sure the flue is clean.
- Check the correct operation of the equipment.

After assembling all the gas connections, a test for gas tightness must be carried out using soapy water or special products. Do not use naked flames.

Maintenance and check of equipment and safety devices should be carried out at the end of each season only by authorized technical personnel.

4.7 FAULT FINDING

The burner does not ignite.

- This means that the flue smoke stat has tripped off (point 3.2)
- Make sure power arrives to the gas valve.
- Replace the electric operator of the valve.
- Replace the valve.

The boiler reaches the set temperature, but the radiators do not heat up.

- Make sure there are no air bubbles in the system, if so purge from

appropriate air vents.

- The room stat is too low or must be replaced if faulty.
- The connections of the room stat are not correct. Make sure the cables are placed on terminals 1 and 4 of the boiler terminal board.
- The circulation pump is blocked, unblock it.
- The electric winding of the circulation pump is faulty, replace the pump.

The boiler pressure relief valve opens often.

- Make sure the system cold water pressure is not too high, follow the suggested values.
- If the pressure relief valve is faulty, replace it.
- Check pre-load pressure of the expansion tank.
- Replace the expansion tank if faulty.

The boiler gets dirty easily causing scaling of cast iron exchanger and cutting off of smoke stat.

- Make sure the main burner flame is well regulated and the gas consumption is proportional to the boiler output.
- The boiler is installed in a poorly ventilated room.
- Insufficient flue draught or not complying with existing standards
- The boiler operates at too low temperatures, set the boiler stat at higher temperatures.

The thermostat re-ignites with too high temperature drop.

- Replace the boiler stat which is faulty.

USER INSTRUCTIONS



WARNINGS

- In case of fault and/or incorrect equipment operation, deactivate it, without making any repairs or taking any direct action. Contact the nearest Authorised Technical Service Centre.
- The installation of the boiler and any servicing or maintenance job must be carried out by qualified personnel. Under no circumstances, the devices sealed by the manufacturer can be tampered with.
- It is absolutely prohibited to block the intake grilles and the aeration opening of the room where the equipment is installed.

LIGHTING AND OPERATION

BOILER IGNITION

To ignite the boilers "RX" it is enough to switch on the switch [1] to make the boiler operate and begin heating.

ADJUSTMENT OF HEATING TEMPERATURE

The heating temperature can be adjusted with the stat knob with a range from 45°C to 85°C (16 fig. 11). The temperature setting can be checked on the thermometer (5 fig. 11). For an always optimum operation of the boiler we recommend not to reduce the operating temperature below 60°C.

LOCK OUT RESET OF THE CONTROL BOX

If the burner does not ignite lock-out lamp will be activated (2 fig. 11). Press the resetting button to make the boiler automatically start.

If, after trying to release the boiler two or three times, this does not regularly start, call on the authorized technical personnel.

SWITCHING OFF THE BOILER

To switch off the boilers "RX" it is enough to turn off the switch [1 fig. 11] to turn off the boiler. Close the gas pipe

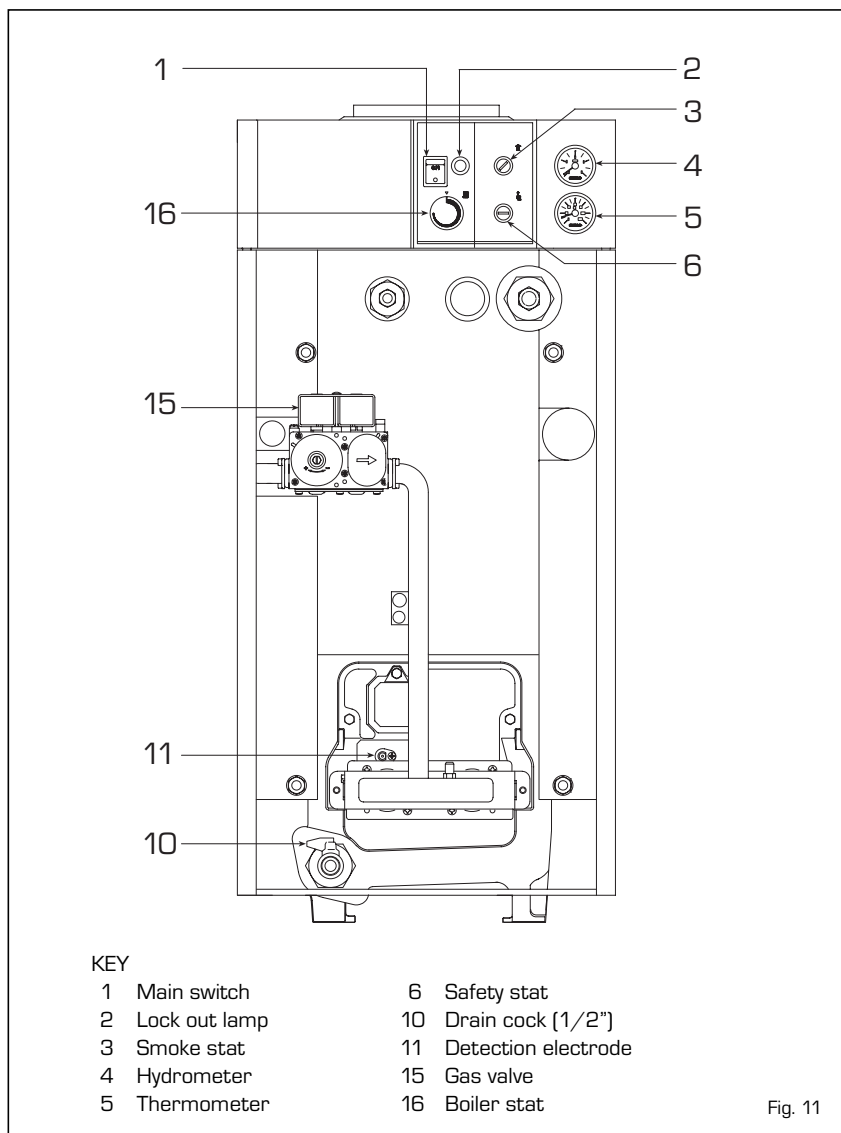

IT

ES

PT

GB

GR

RO

RUS

SCG

cock if you are not going to use the boiler for a long time.

SAFETY STAT

"RX 37+55" models are equipped with safety stat (6 fig. 11) with manual resetting. In case the boiler temperature exceeds 95°C the safety stat will extinguish the pilot burner thus shutting off the gas flow to the pilot and main burner.

Should the stat trip off, it will be necessary to unscrew the cover and reset the button below for the pilot burner to restart (fig. 12).

Should the boiler "lock out" again, you must call the authorized technical staff.

SMOKE SAFETY DEVICE

It is a safety device which controls the correct discharge of flue gas into the atmosphere (3 fig. 11).

The control device stops the gas valve if the flue gas is discharged into the boiler room in continuous way and in such quantities as to become dangerous.

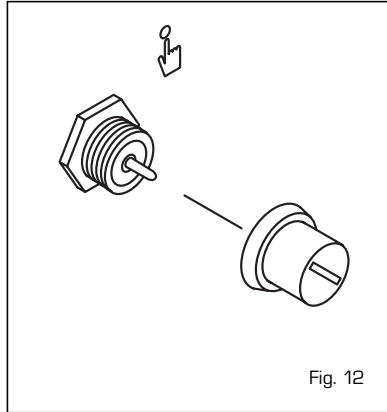

To start the boiler again, switch off the power, then remove the smoke stat cover and reset the button below (fig. 12).

If the boiler stops again, it will be necessary to call the authorized technical staff.

SYSTEM FILLING

Check periodically that the hydrometer (4 fig. 11) has pressure values at a switched-off system of **1 - 1,2 bar**.

If the pressure is less than 1 bar, re-

charge it rotating the knob anti-clockwise. After the operation check that the tap is properly closed.

Should the pressure exceed the foreseen limit, discharge the superfluous amount by operating on the vent knob of any radiator.

GAS CONVERSION

Should a gas other than that for which the boiler is equipped be used, the conversion has to be carried out by technical personnel authorized by the manufacturer.

CLEANING AND MAINTENANCE

When the heating is turned off at the end of the season, it is compulsory to check the boiler and clean it.

Maintenance and check of equipment and safety devices shall be carried out only by authorized technical personnel. The boiler is supplied with an electric cable. Should this require replacement, get in touch exclusively with the authorized technical staff.