



Fitting Instructions Grande Combi Floor Standing

7.3 Grande Combi Floor Standing Balance Flue

Step 1:

- a). Fitting to a rear wall only. See Fig 41.
- b). Fitting to left side wall only. See Fig 42.
- c). Fitting to a right side wall only. See Fig 43.

Fig 41 Fitting a REAR balanced-flue

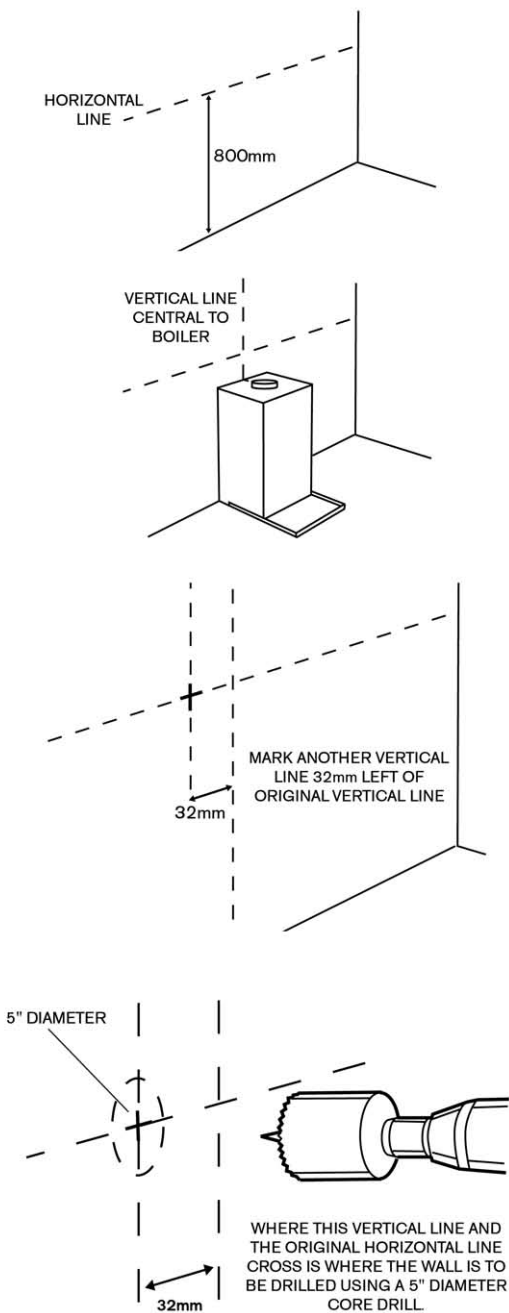
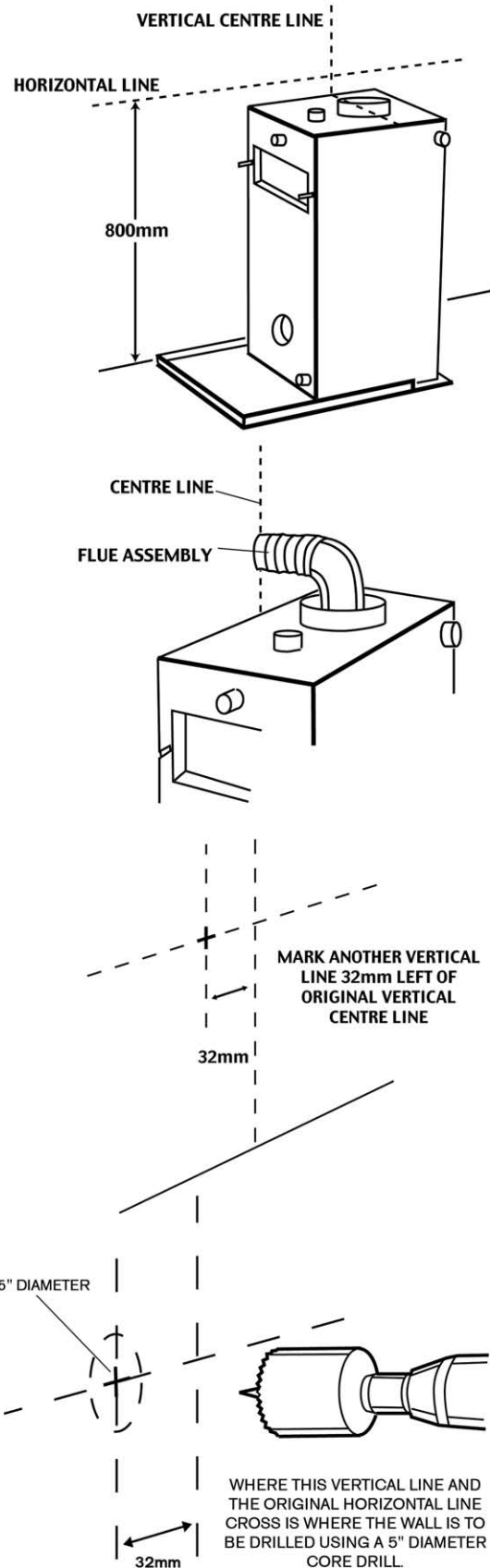
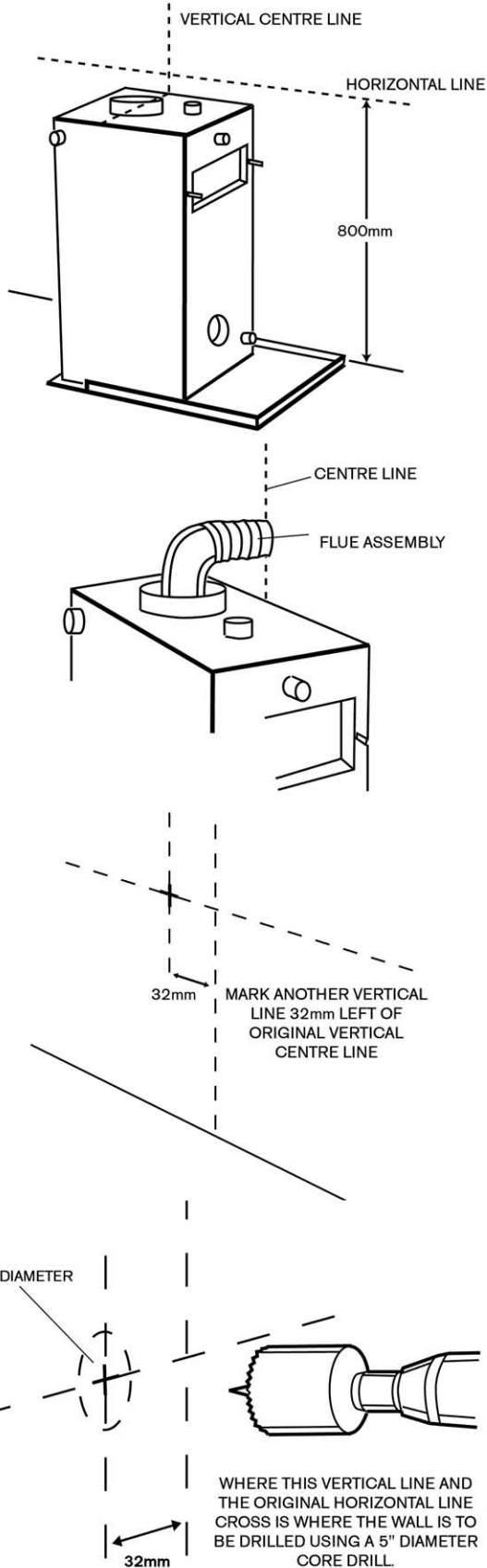

Fig 42. Fitting a LEFT-HAND balanced-flue



COMBI

Fig 43 Fitting a RIGHT-HAND balanced-flue



Step 2:

From the outside of the dwelling offer the flue assembly through the 5" hole making sure the assembly is square and flat against the wall.

Mark the flue assembly fixing holes. See Fig 44.

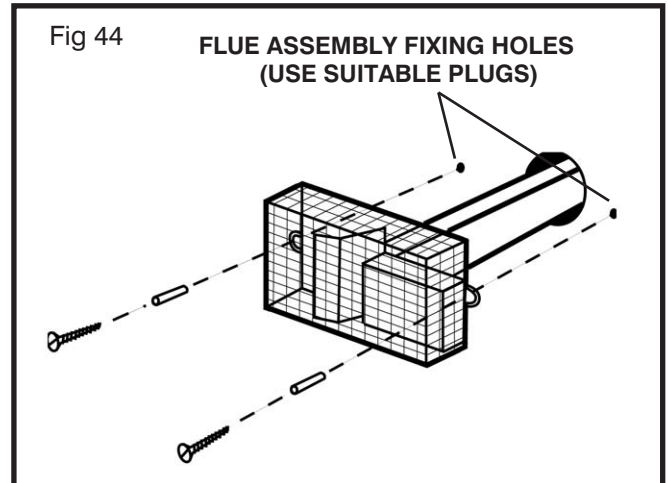

Step 3:

Leaving the assembly in its final position (but not fastened to the wall) go into the dwelling to the inside protruding flue and air ducts and mark 30mm protrusion into the dwelling - that is, beyond the inside wall.

See Fig 45

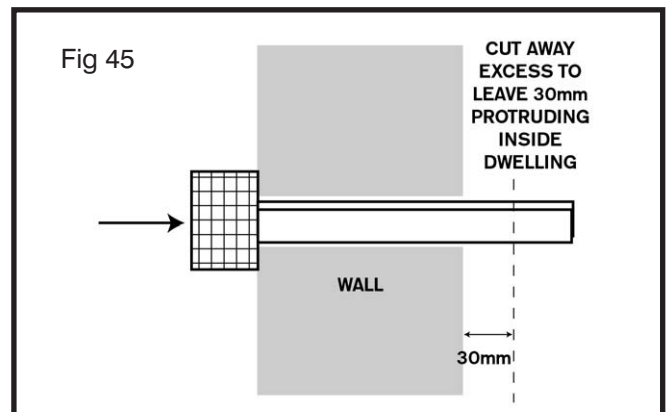

Step 4:

Remove the flue assembly kit from outside and cut the air and flue ducts to the correct length as marked.

Step 5:

Drill and plug the flue assembly holes. See Fig 44.

Step 6:

From outside reposition the flue assembly holes and fasten to wall. Your exterior work is now complete.

Step 7:

Return to inside the dwelling and slide wall plate over the protruding air and flue ducts. You may, if preferred, first make good the cavity between the ducts and the hole. Screw wall plate to inner wall. See Fig 46.

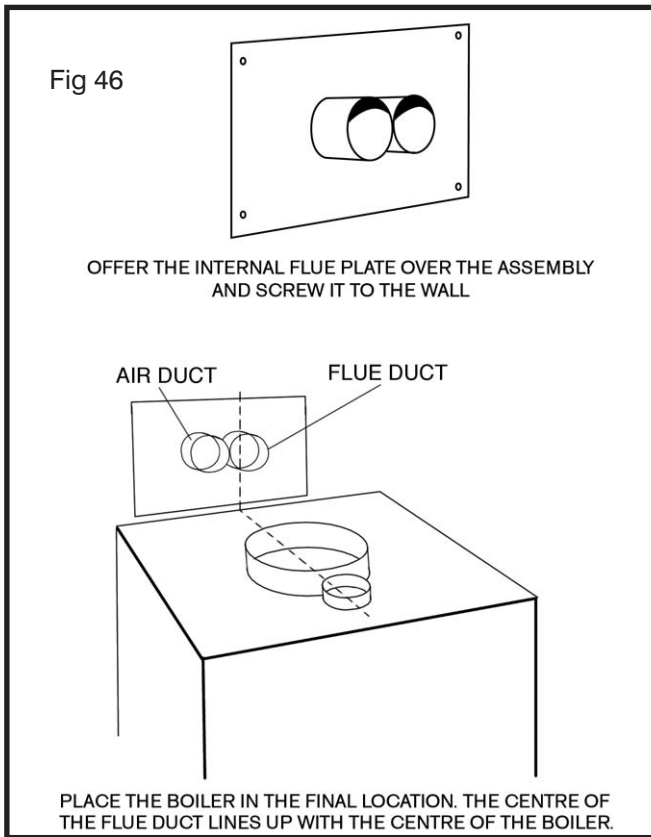

Step 8:

Place the boiler in its eventual location making sure to line up the centre of the flue with the centre of the flue duct. **NOTE: THIS IS THE RIGHT HAND DUCT.** The air duct is offset to the left. See Fig 46.

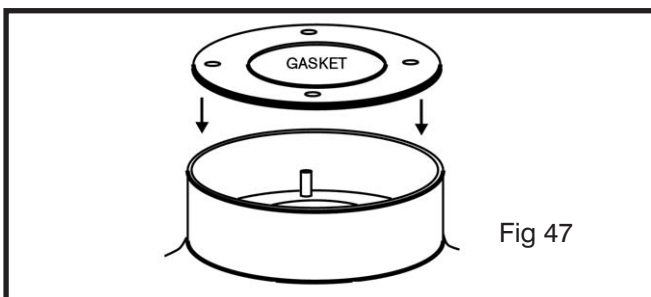

Step 9:

Place the large circular gasket provided inside the collar on the top of the boiler. See Fig 47.

Step 10:

Using the heat resistant hose provided, couple up the flue to

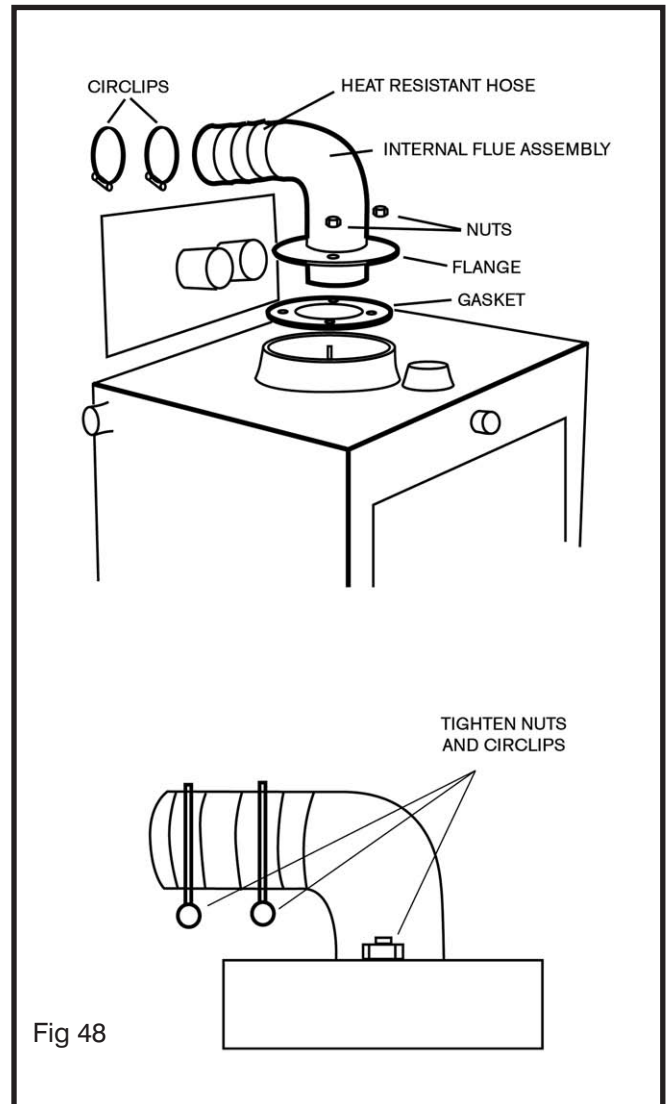

the internal flue assembly using circlips. Some twisting may be necessary to ensure a proper coupling. Tighten flue flange, using the gasket provide, onto the boiler to make a proper seal. If in doubt, apply fire cement as necessary. See Fig 48.

Step 11:

Cut the flexible air inlet tube to suit and fix onto air inlet and tighten with circlip.

NOTE: The air inlet tube to the burner is deliberately oversized to provide adequate length for handed flues. Cut to length as appropriate.

- a). Fitting to a rear wall only. See Fig 49.
- b). Fitting to left side wall only. See Fig 50.
- c). Fitting to a right side wall only. See Fig 51.

IMPORTANT NOTE: Ensure the plastic air inlet hose does not come into contact with the hot flue assembly.



Fitting Instructions Grandee Combi Floor Standing

COMBI

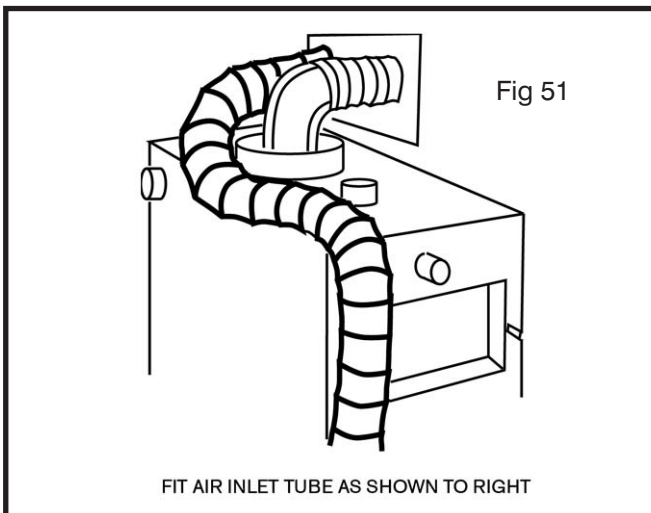
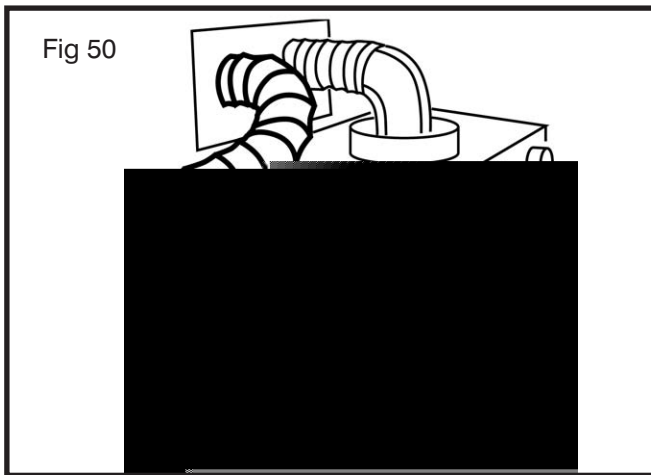
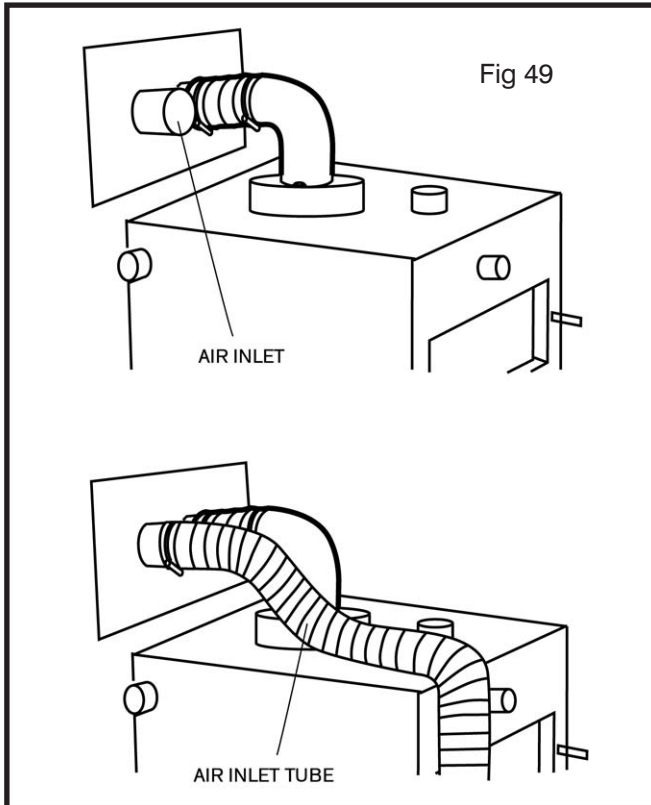

Step 12:

Make primary flow and return, oil and electric connections as appropriate.

Step 13:

For left or right handed boilers only

Detach removable access panel from left or right side of boiler casing as appropriate. Fig 52.

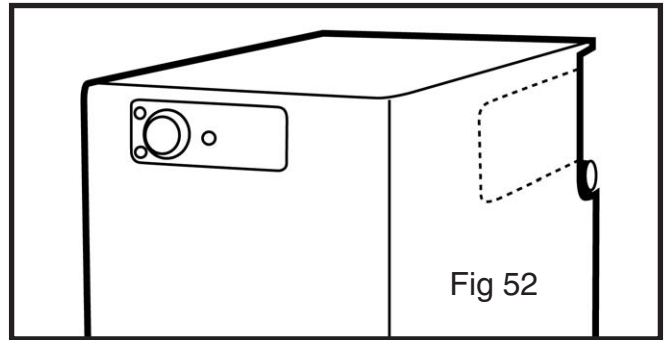

7.4 Grandee Combi Floor Standing Conventional Flue

Step 1:

Use suitable flue pipe and ensure complete seal either within or outside the flue spigot. See Fig 53.

Step 2:

Using a sharp knife carefully cut the insulation on the inside of the casing around the louvres to enable the passage of air for combustion which in turn, will flood through the louvred air inlet. See Fig 53.

Step 3:

Check that free air is available in the room and fit an air brick if necessary.

