

INSTALLATION AND SERVICING

Flexicom

12hx

G.C. No. 41-315-28

15hx

G.C. No. 41-315-29

18hx

G.C. No. 41-315-42

24hx

G.C. No. 41-315-61

**High Efficiency
Condensing
Boilers**

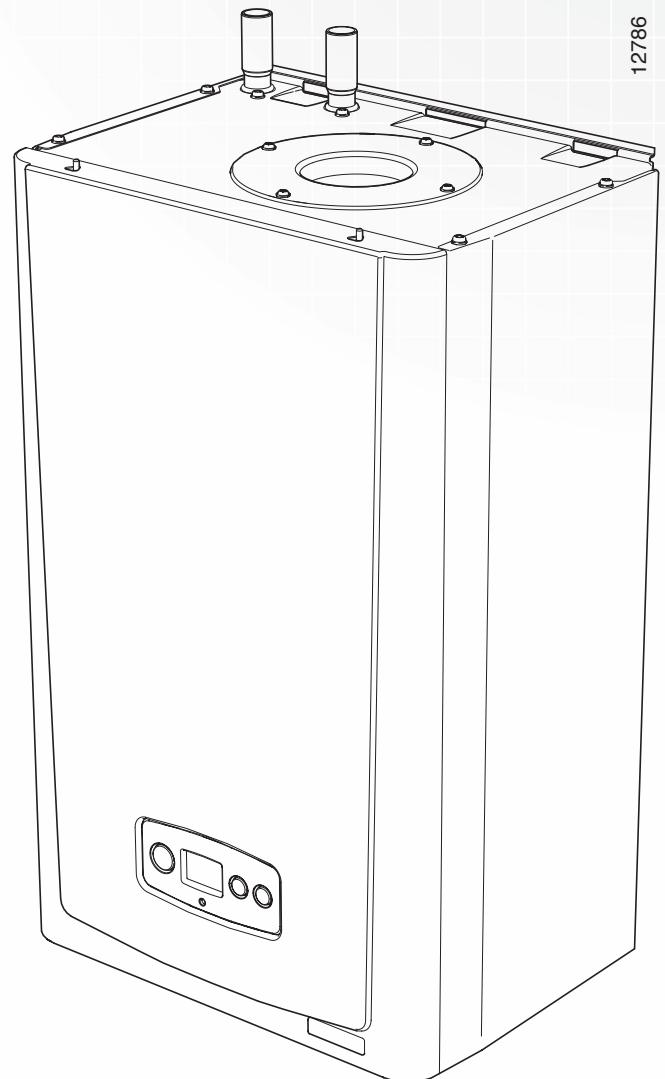

Glow-worm, Nottingham Road, Belper, Derbyshire. DE56 1JT

www.glow-worm.co.uk

Guarantee Registration

Thank you for installing a new Glow-worm appliance in your home.

Glow-worm appliances are manufactured to the very highest standard so we are pleased to offer our customers a Comprehensive Guarantee.

This product is guaranteed for 24 months from the date of installation or 30 months from the date of manufacture, whichever is the shorter, for parts. In addition this product is guaranteed for 12 months from the date of installation or 18 months from the date of manufacture, whichever is the shorter, for labour.

The second year of the parts guarantee, from the beginning of the 13th month onwards after installation or manufacture, is conditional upon the boiler having been serviced by a CORGI registered gas installer,

in accordance with the manufacturer's recommendations. We strongly recommend regular servicing of your gas appliance, but where the condition is not met, any chargeable spare parts or components issued within the applicable guarantee period still benefit from a 12 month warranty from the date of issue by the manufacturer.

We recommend you complete and return as soon as possible your guarantee registration card. If your guarantee registration card is missing you can obtain a copy or record your registration by telephoning the Glow-worm Customer Service number 01773 828100.

Customer Service:

01773 828100

Technical Helpline:

01773 828300

General and Sales enquiries:

Tel. 01773 824639

Fax: 01773 820569

**To register your Glow-worm appliance
call:**

0800 0732142



*The code of practice for the installation,
commissioning & servicing of gas central heating*

The instructions consist of two parts, Installation and Servicing Instructions. The instructions are an integral part of the appliance and must, to comply with the current issue of the Gas Safety (Installation and Use) Regulations, be handed to the user on completion of the installation.

CONTENTS	DESCRIPTION	SECTION	PAGE
INTRODUCTION	Warnings		4
	Important Information		4
	General Information		5
	Appliance Safety Devices		6
	Maintenance and Servicing		6
INSTALLATION INSTRUCTIONS	Technical Information	1	7
	Boiler Location and Ventilation	2	9
	Flue Options & Terminal Clearances	3	10
	Water System	4	12
	Installation Preparation	5	15
	Boiler Fixing	6	16
	Gas/Water & Appliance Connection	7	17
	Condensate Connection	8	18
	Flue Preparation and Installation	9	20
	Electrical Connection	10	33
	Commissioning	11	35
	Servicing	12	36
	Fault Finding	13	40
	Replacement of Parts	14	46
	Spare Parts	15	52
	Manual Handling	16	53

WARNINGS

Gas Leak or Fault

Turn off the gas emergency control valve immediately. Eliminate all sources of ignition, i.e. smoking, blowlamps, hot air guns etc. Do not operate electrical lights or switches either on or off. Open all doors and windows, ventilate the area.

Sheet Metal Parts

This boiler contains metal parts (components) and care should be taken when handling and cleaning, with particular regard to edges.

Sealed Components

Under no circumstances must the User interfere with or adjust sealed parts.

Important Information

Gas Category

This boiler is for use only on G20 natural gas.

Gas Safety (Installation and Use) Regulations

In your own interests and that of safety, it is the Law that ALL gas appliances are installed by a competent person in accordance with the current issue of the above regulations.

Testing and Certification

This boiler is tested and certificated for safety and performance. It is, therefore, important that no alteration is made to the boiler, without permission, in writing, by Glow-worm. Any alteration not approved by Glow-worm, could invalidate the certification, boiler warranty and may also infringe the current issue of the statutory requirements.

CE Mark

This boiler meets the requirements of Statutory Instrument, No. 3083 The Boiler (Efficiency) Regulations, and therefore is deemed to meet the requirements of Directive 92/42/EEC on the efficiency requirements for new hot water boilers fired with liquid or gaseous fuels.

Type test for purposes of Regulation 5 certified by: Notified body 0087.

Product/production certified by: Notified body 0086.

The CE mark on this appliance shows compliance with:

1. Directive 90/396/EEC on the approximation of the laws of the Member States relating to appliances burning gaseous fuels.
2. Directive 73/23/EEC on the harmonisation of the Laws of the Member States relating to electrical equipment designed for use within certain voltage limits.
3. Directive 89/336/EEC on the approximation of the Laws of the Member States relating to electromagnetic compatibility.

Control of Substances Hazardous to Health

Under Section 6 of The Health and Safety at Work Act 1974, we are required to provide information on substances hazardous to health.

The adhesives and sealants used in this appliance are cured and give no known hazard in this state.

Electrical Supply

The boiler must be earthed.

All system components shall be of an approved type and all wiring to current I.E.E. wiring regulations.

External wiring must be correctly earthed, polarised and in accordance with the relevant standards.

In GB this is BS 7671.

In IE this is the current edition of I.S.813 "Domestic Gas Installations".

The boiler must be connected to a permanent 230V ac, 50Hz supply.

Connection of the whole electrical system of the boiler, including any heating controls, to the electrical supply must be through one common isolator and must be fused 3 Amp maximum.

Isolation should be by a double pole switched fused spur box, with a minimum gap of 3mm for both poles. The fused spur box should be readily accessible and preferably adjacent to the appliance. It should be identified as to its use.

Alternatively connection can be made through an unswitched shuttered socket and 3A fused 3-pin plug both to the current issue of BS 1363, provided they are not used in a room containing a bath or shower.

Wiring to the boiler must be PVC 85°C insulated cable, not less than 0.75mm² (24/0.20mm).

IMPORTANT NOTE

ALL electrical connections to the boiler must be permanently fixed to a wall or a sturdy support feature in a tidy manner.

General Information

General Note

Once the controls are set the boiler operates automatically. Please read these instructions and follow them carefully for the correct installation and economical use of your boiler.

Water Treatment

In the case of an existing system, it is ESSENTIAL that prior to installing the new boiler the system is thoroughly flushed. For optimum performance after installation of a new system, the boiler and its associated central heating system should also be flushed. Flushing should be carried out in accordance with BS7593: 1992 using a cleanser such as Sentinel X300 or X400, Fernox Restorer or Salamander corrosion guard cleaner.

For long-term corrosion protection, after flushing, a suitable inhibitor should be used, refer to the current issue of BS 5449 and BS 7593 on the use of inhibitors in central heating systems. Examples are Sentinel X100, Fernox Protector or Salamander corrosion guard inhibitor.

Compartment or Cupboard Installations

If the boiler is fitted into a compartment or cupboard it does not require ventilation openings.
Do not use the compartment or cupboard for storage.

Clearances

If fixtures are positioned close to the boiler, space must be left as shown in diagram 2.1.

Condensate Drain

The condensate drain, see diagram 8.2, must not be modified or blocked.

Plumbing from flue terminal

Like all condensing boilers this appliance will produce a plume of condensation from the flue terminal in cool weather. This is due to the high efficiency and hence low flue gas temperature of the boiler. It is normal and not a fault indication.

Electrical Supply

If the mains electricity and gas are to be turned off for any long periods during severe weather, it is recommended that the whole system, including the boiler, should be drained to avoid the risk of freezing. Make sure that, if fitted, the immersion heater in the cylinder is switched off.

NOTE: If you have a sealed water system contact your installation/servicing company as draining, refilling and pressurising MUST be carried out by a **competent person**.

Manual Handling

IMPORTANT: With regards to the "Manual Handling Operations, 1992 Regulations", the appliance is deemed to be a one person lift.

Appliance Safety Devices

Electrical Supply Failure

The boiler will not work without an electrical supply. Normal operation of the boiler should resume when the electrical supply is restored. Reset any external controls, to resume normal operation of the central heating. If the boiler does not resume normal operation press reset button on fascia.

Overheating safety

In the event of the boiler overheating the safety devices will cause a safety shutdown. If this happens, press the reset button before calling your Installation/Service company.

Frost protection

The appliance has a built in frost protection device that protects the boiler from freezing. With the gas and electric supplies ON and irrespective of any room thermostat setting, the frost protection device will operate the pump when the temperature of the boiler water falls below 8°C.

A timer is used so that the temperature can be checked periodically. After 10 minutes the pump will be stopped if the temperature is higher than 10°C or has already reached 35°C.

The burner will activate if the boiler temperature does not reach 10°C after 30 minutes or at any time if the temperature drops to 5°C.

The burner will switch off when the temperature reaches 35°C.

Condensate Drain Blockage

As a safety feature the boiler will stop working if the condensate drain becomes blocked. During freezing conditions this may be due to the forming of ice in the condensate drain external to the house. Release an ice blockage by the use of warm cloths on the pipe. The boiler should then restart. Contact your installation/service company if the fault persists.

Maintenance and Servicing

Maintenance and Servicing

To ensure the continued efficient and safe operation of the appliance it is recommended that it is checked and serviced as necessary at regular intervals. The frequency of servicing will depend upon the particular installation conditions and usage.

If this appliance is installed in a rented property there is a duty of care imposed on the owner of the property by the current issue of the Gas Safety (Installation and Use) Regulations, Section 35.

Servicing/maintenance should be carried out by a **competent person** in accordance with the rules in force in the countries of destination.

To obtain service, please call your installer or Glow-worm's own service organisation using the telephone number on the inside front cover of this literature.

Please be advised that the 'Benchmark' logbook, located at centre of the literature, should be completed by the installation engineer on completion of commissioning and servicing.

Spare Parts

Remember, when replacing a part on this appliance, use only spare parts that you can be assured conform to the safety and performance specification that we require. Do not use reconditioned or copy parts that have not been clearly authorised by Glow-worm.

If a part is required contact Glow-worm's own service organisation using the telephone number on the inside front cover of this booklet.

Please quote the name of the appliance, this information will be on the name badge on the front of the appliance.

If in doubt seek advice from the local gas company or Glow-worm's own service organisation using the telephone number on the inside front cover of this booklet.

1 Technical Information

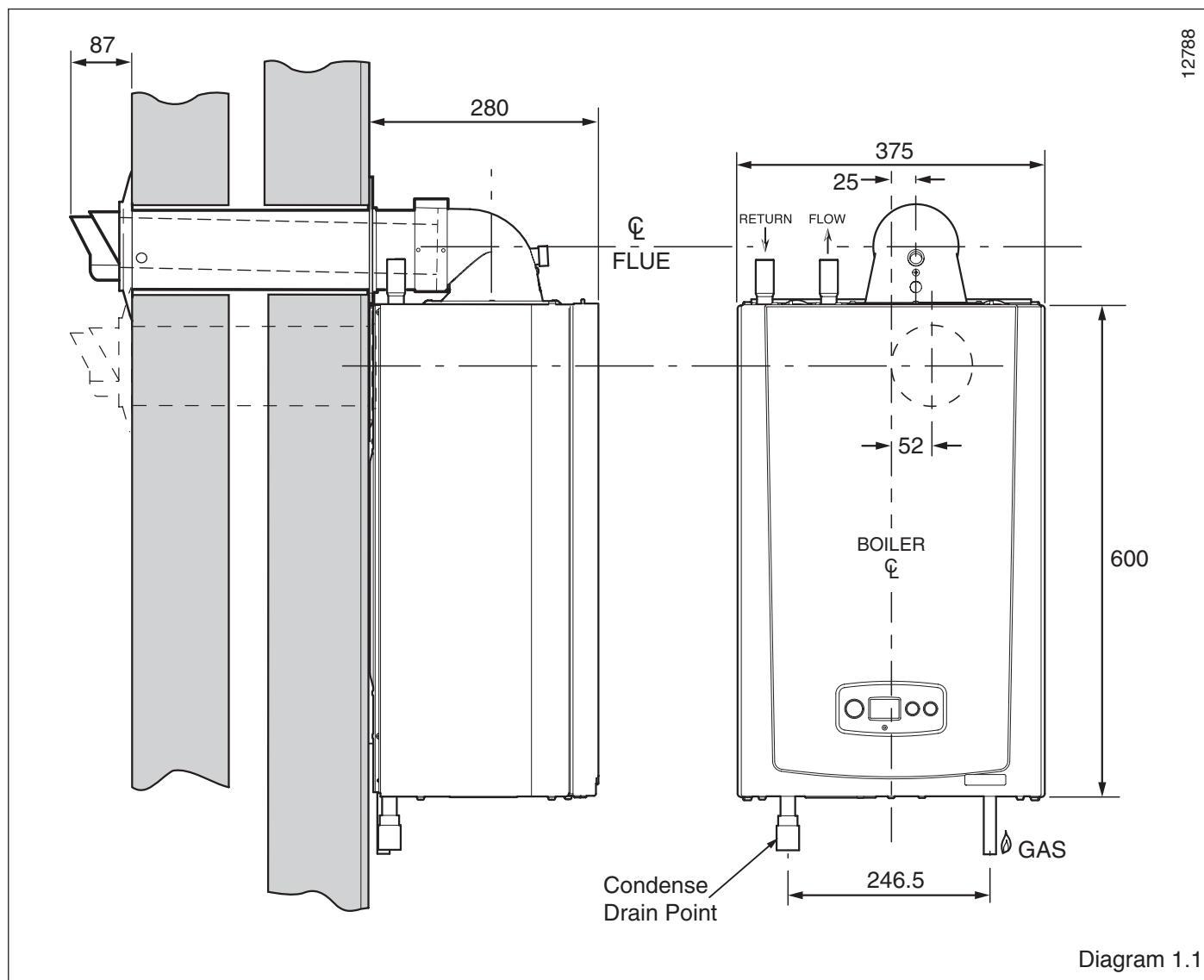

1.1 IMPORTANT

The boiler is supplied in one carton, which includes the appliance fixings and fittings, see diagram 5.1.

The flue is supplied separately.

This boiler is for use only on G20 natural gas.

Where no British Standards exists, materials and equipment should be fit for their purpose and of suitable quality and workmanship.

The installation of this boiler must be carried out by a **competent person** in accordance the rules in force in the countries of destination.

Manufacturer's instructions must not be taken as overriding statutory requirements.

1.2 Statutory Requirements

In GB the installation of the boiler must be carried out by a **competent person** as described in the following regulations:

The manufacturer's instructions supplied.

The Gas Safety (Installation and Use) Regulations.

The appropriate Buildings Regulations either The Building Regulations, The Building Regulations (Scotland), The Building Regulations (Northern Ireland).

The Water Fittings Regulations or Water byelaws in Scotland.

The Health and Safety at Work Act, Control of Substances Hazardous to Health (COSHH).

The Current I.E.E. Wiring Regulations.

Where no specific instructions are given, reference should be made to the relevant British Standard Code of Practice.

In IE, the installation must be carried out by a **competent person** and installed in accordance with the current edition of I.S.813 "Domestic Gas Installations", the current Building Regulations and reference should be made to the current ETCI rules for Electrical Installation.

In GB the following Codes of Practice apply:

BS4814, BS6798, BS5440 Part 1 and 2, BS5546 Part 1, BS5449, BS6891, BS6700, BS7074 Part 1 and 2, BS7593, BS7671.

In IE: I.S.813, BS5546, BS 5449, BS 7074, BS 7593.

Manufacturer's instructions must not be taken as overriding statutory requirements.

NOTE: For further information, see the current issue of the Building Regulations, approved document L1 (in the UK) and the references:

- 1) Central heating system specification (CheSS) and
- 2) Controls for domestic central heating system and hot water. BRECSU.

1 Technical Information

1.3 Technical Data

All dimensions are given in millimetres (except as noted).
See diagrams 1.1 and 1.2.
The data label is positioned on the base of the boiler.

1.4 Gas Supply

The gas installation must be in accordance with the relevant standards.

In GB this is BS6891.

In IE this is the current edition of I.S.813 "Domestic Gas Installations".

The supply from the governed meter must be of adequate size to provide a steady inlet working pressure of 20mbar (8in wg) at the boiler.

On completion, test the gas installation for soundness using the pressure drop method and suitable leak detection fluid, purge in accordance with the above standard.

1.5 Condensate Drain

A plastic drain pipe must be fitted to allow discharge of condensate to a drain.

Condensate should, if possible, be discharged into the internal household draining system. If this is not practical, discharge can be made externally into the household drainage system or a purpose designed soak away, see section 8 for more details.

BOILER SPECIFICATION		12hx to 24hx			
Lift weight		25kg (55lb)			
Total weight (installed)		28kg (62lb)			
Gas connection Ø O.D.		15mm. copper			
Heating Flow & Retrn connection Ø O.D.		22mm. copper			
Condensate connection Ø I.D.		21.5mm. plastic			
Electrical supply		230V~50Hz			
Electrical rating		60W fused 3A			
IP classification		X4D			
Internal fuse rating on main PCB		2A			
Gas supply (governed metre only)		I ₂ H G20 natural gas			
Inlet gas working pressure		20mbar			
Burner % CO ₂ case on		9.3 nominal			
Burner % CO ₂ case off		9.3 nominal			
		12hx	15hx	18hx	24hx
Approximate max. gas rate after 10 mins. from cold	m ³ /h	1.28	1.60	1.93	2.58
	ft ³ /h	45	56.5	68.1	90.9
Approximate min. gas rate after 10 mins. from cold	m ³ /h	0.99	0.99	0.99	0.99
	ft ³ /h	35.1	35.1	35.1	35.1
Heat input NETT Q = kW	max.	12.1	15.1	18.2	24.4
	min.	9.4	9.4	9.4	9.4
Heat output P = kW	max.	12	15	18	24
	min.	9.3	9.3	9.3	9.3
Flue type (all models)		C ₁₃ , C ₃₃ , C ₅₃			
NO _x (all models)		Class 5			

13214

Diagram 1.2

3 Flue Options and Terminal Clearances

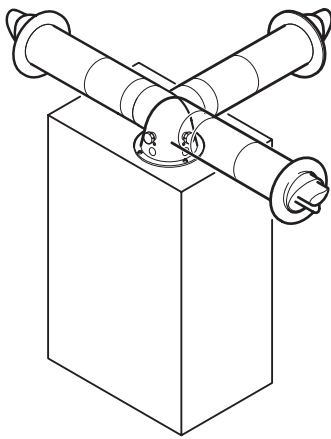

Top horizontal telescopic flue Ø60/100
Part No. A2043600

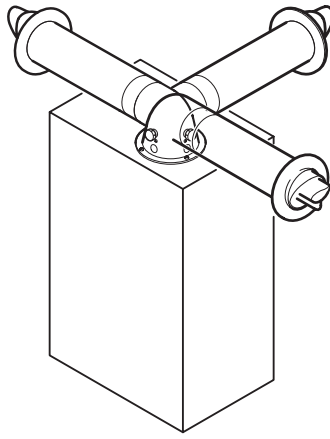

Top horizontal standard flue Ø60/100
Part No. A2043400

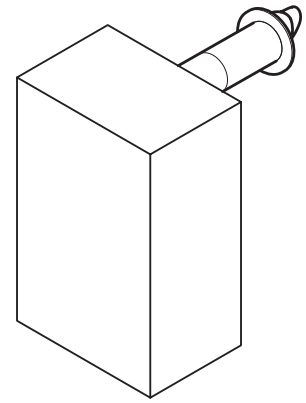

Rear telescopic flue Ø60/100
Part No. A2043500

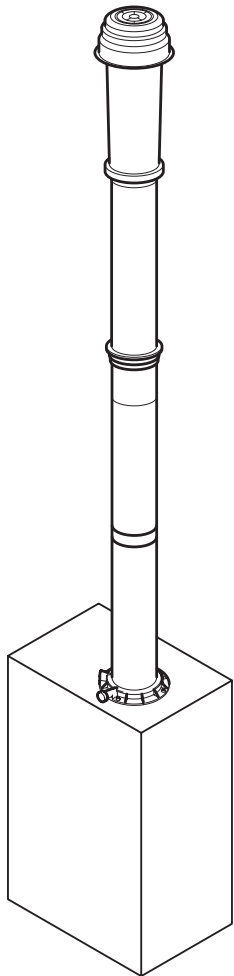

Vertical Flue
Vertical Flue Adapter, concentric flue Ø60/100
Part No. A2024600
Vertical flue terminal kit, concentric flue Ø60/100
Part No. 2000460480

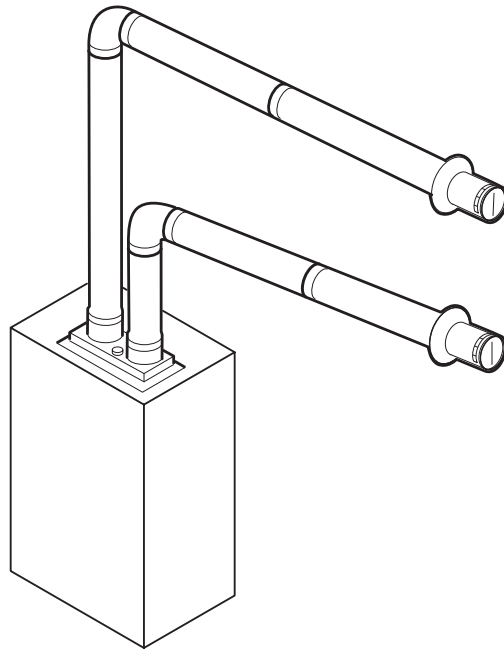

Twin Flue
Twin Flue Adapter, concentric flue Ø80
Part No. A2011000

Flue Accessories

Black Horizontal Terminal Kit, for use with
A2043500; A2043600; A2043400
Black Horizontal Terminal Kit,
concentric flue Ø60/100 - Part No. A2043700

Plume Management Kit, for use with
A2043500; A2043600; A2043400
Plume Management Kit, basic set, white,
concentric flue Ø60/100 - Part No. A2044100
1m extension, white - Part No. A2044300
87° elbow, white - Part No. A2044700
45° bend (2), white - Part No. A2044500
Plume Management Kit, basic set, black,
concentric flue Ø60/100 - Part No. A2044000
1m extension, black - Part No. A2044200
87° elbow, black - Part No. A2044600
45° bend (2), black - Part No. A2044400

Concentric Flue Ø60/100 accessories:
2 metre extension kit, concentric flue
Ø60/100 - Part No. 2000460483
1 metre extension kit, concentric flue
Ø60/100 - Part No. 2000460482
0.5 metre extension kit, concentric flue
Ø60/100 - Part No. 2000460481
Adjustable flue pipe 0-50mm kit,
concentric flue Ø60/100 - Part No. 2000460487
90° flue elbow pack,
concentric flue Ø60/100 - Part No. 2000460484
45° flue bend pack,
concentric flue Ø60/100 - Part No. 2000460485
Flue support clips (3),
concentric flue Ø60/100 - Part No. A2043900

Additional accessories are available.
See Glow-worm "Flexicom Range Guide" for
configurations available.

Diagram 3.1

3 Flue Options and Terminal Clearances

3.1 Flue Options

There are various flue options to choose from as illustrated in diagram 3.1. The flue lengths and installation are described in section 9.

3.2 Flue Terminal Position

The minimum acceptable siting dimensions for the terminal from obstructions, other terminals and ventilation openings are shown in diagram 3.2. For Ireland the minimum distances for flue terminal positioning must be those detailed in I.S.813 "Domestic Gas Installations".

The terminal must be exposed to the external air, allowing free passage of air across it at all times.

Being a condensing boiler some plumbing may occur from the flue outlet. This should be taken into consideration when selecting the position for the terminal.

NOTE: If necessary it is permitted to increase the terminal protrusion through the outside wall to greater than the minimum dimension of 87mm but no more than 600mm, see diagram 1.1. Carports or similar extensions of a roof only, or a roof and one wall, require special consideration with respect to any openings, doors, vents or windows under the roof. Care is required to protect the roof if made of plastic sheeting. If the carport comprises of a roof and two or more walls, seek advice from the local gas supply company before installing the boiler.

H* and J* See diagram 3.2. These dimensions comply with the building regulations, but they may need to be increased to avoid wall staining and nuisance from plumbing depending on site conditions.

Plume Management Kit: Part No.A2044100 (white) or A2044000 (black) can be used to overcome many site issues.

3.3 Terminal Guard

A terminal guard is required if persons could come into contact with the terminal or the terminal could be subject to damage.

If a terminal guard is required, it must be positioned to provide minimum of 50mm clearance from any part of the terminal and be central over the terminal.

The guard should be similar to that shown in diagram 3.3.

A suitable guard is manufactured by: -

Tower Flue Components

Morley Rd.

Tonbridge

Kent

TN9 1RA.

Size: 280mm x 280mm x 270mm.

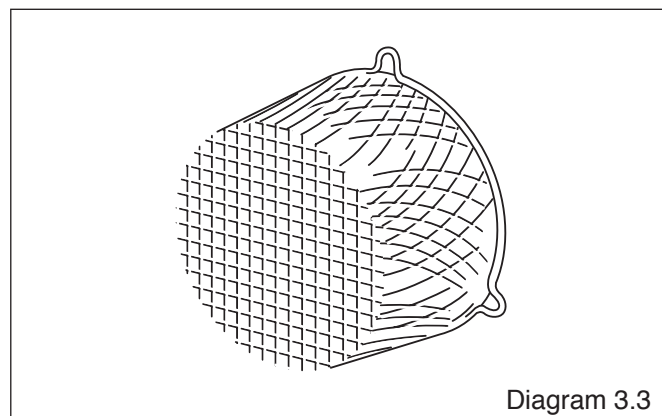
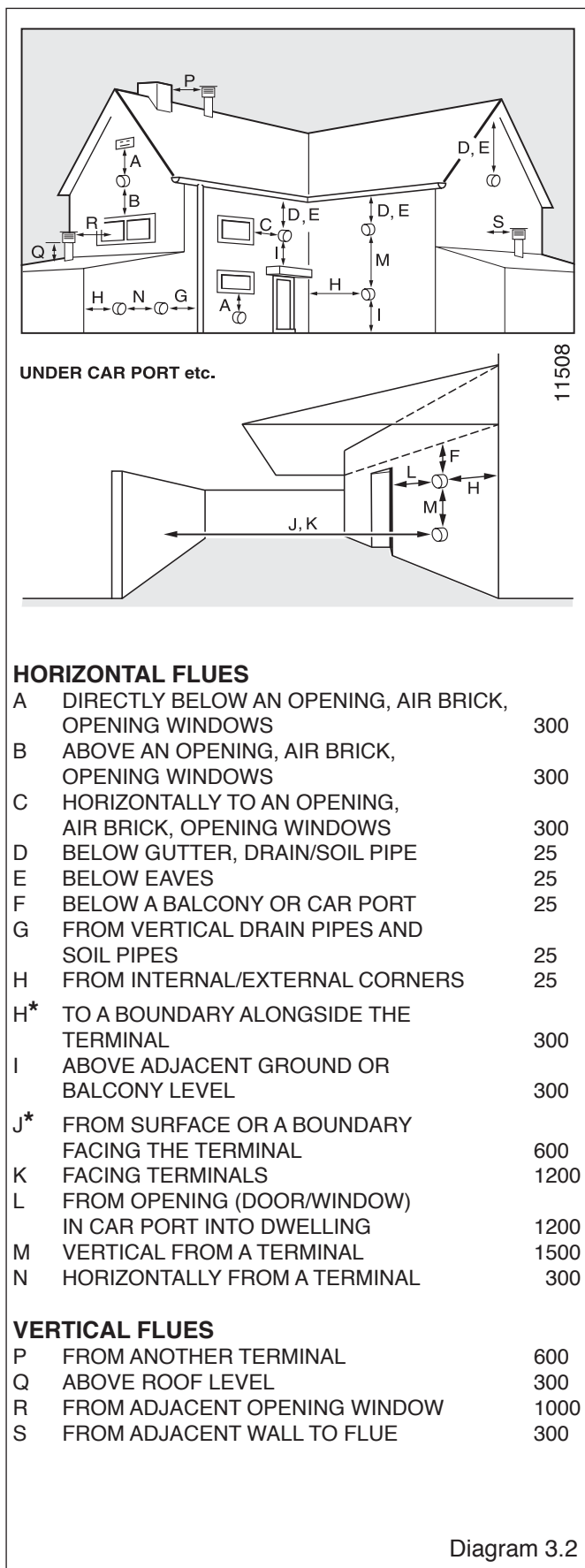

4 Water System

4.1 Safety Valve

A safety valve need not be fitted to an open-vented system.

4.2 Pump

The pump should be fitted on the flow pipe from the boiler and have isolating valves each side.

A variable duty pump should be set to give a temperature difference of no greater than 20°C between the flow and return, with the thermostat set at "MAX", which is about 80°C, to give a flow rate as shown in table 3.

See chart for pressure loss of the boiler, diagram 4.1.

High resistance microbore systems may require a higher duty pump.

4.3 Flow Rate

If it is necessary to alter the flow rate, the system can be fitted with a lockable balancing valve in the main flow or return pipes shown in diagram 4.3. The flow rate through the boiler must not be allowed to fall below that given in diagram 4.1.

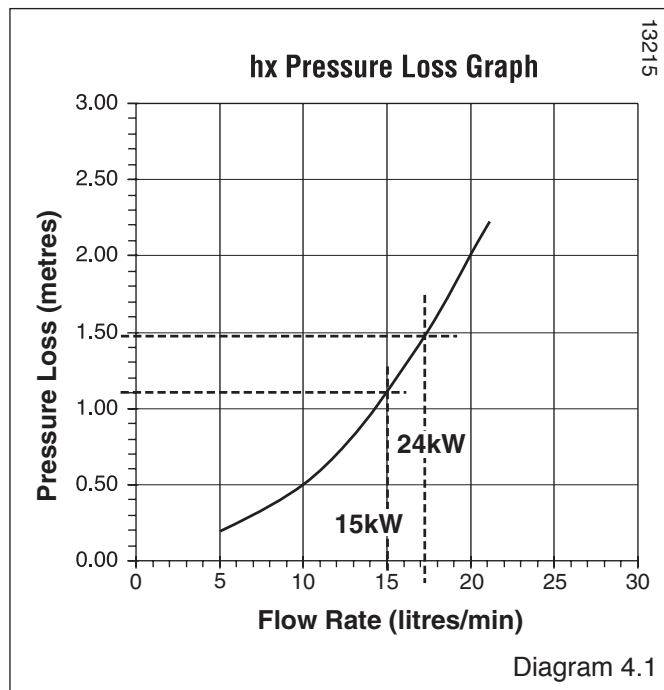

4.4 Bypass

A bypass is not required on the central heating system unless the system controls could allow the boiler and pump to operate when there is no flow.

Where a bypass has to be fitted, the bypass must be placed at least 1.5 metres away from the boiler.

4.5 Water Treatment

In the case of an existing system, it is ESSENTIAL that prior to installing the new boiler the system is thoroughly flushed. For optimum performance after installation of a new system, the boiler and its associated central heating system should also be flushed. Flushing should be carried out in accordance with BS7593: 1992 using a cleanser such as Sentinel X300 or X400, Fernox Restorer or Salamander corrosion guard cleaner.

For long-term corrosion protection, after flushing, a suitable inhibitor should be used, refer to the current issue of BS 5449 and BS 7593 on the use of inhibitors in central heating systems. Examples are Sentinel X100 Fernox Protector or Salamander corrosion guard inhibitor.

4.6 Open (Vented) Water System

The boiler must be supplied from an unrestricted water supply taken from a feed and expansion cistern situated at a maximum height of 27 metres (90ft) above the boiler.

The cold feed must be 15mm minimum size.

The vent must rise continuously and be unrestricted.

It is important that the relative positions of the pump, cold feed and open vent are as shown in diagram 4.2.

4.7 Combined Feed and Vent

For combined feed and vent, a 22mm pipe must be fitted in accordance with BS 5449.

4.8 Domestic Hot Water Cylinder

SINGLE FEED INDIRECT CYLINDERS ARE NOT SUITABLE

The domestic hot water cylinder must be of the double feed fully indirect coil type.

4 Water System

4.9 Draining Points

Draining taps must be provided at the lowest points of the system, which will allow the entire system to be drained. A Draining point for the appliance is provided at the position shown in diagram 4.2.

4.10 Domestic Hot Water System - unvented

General - All domestic hot water circuits, connections, fittings must be in accordance with the relevant standards and water supply regulations.

For GB: Guidance G17 to G24 and recommendation R17 to R24 of the Water Regulations Guide.

For IE: The current edition of I.S.813 "Domestic Gas Installations".

Where a storage system will not have a vent to atmosphere the installation must comply with the building regulations and local Water Company bylaws, see also the current issue of BS5546 and BS6700.

If fitting to an existing system the local authority should be informed.

4.11 Sealed Water Systems

The installation must comply with the appropriate requirements of the current issue of BS4814, BS5449, BS6759, BS6798 and BS7074 Part 1 and 2.

See diagram 4.3 for a suggested layout.

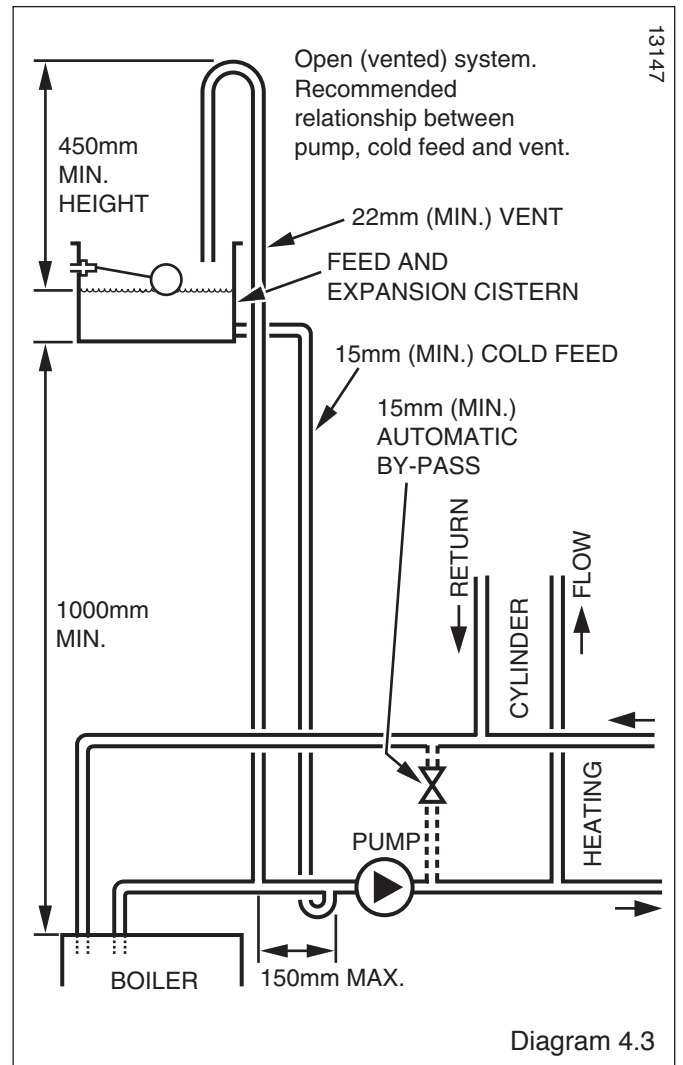
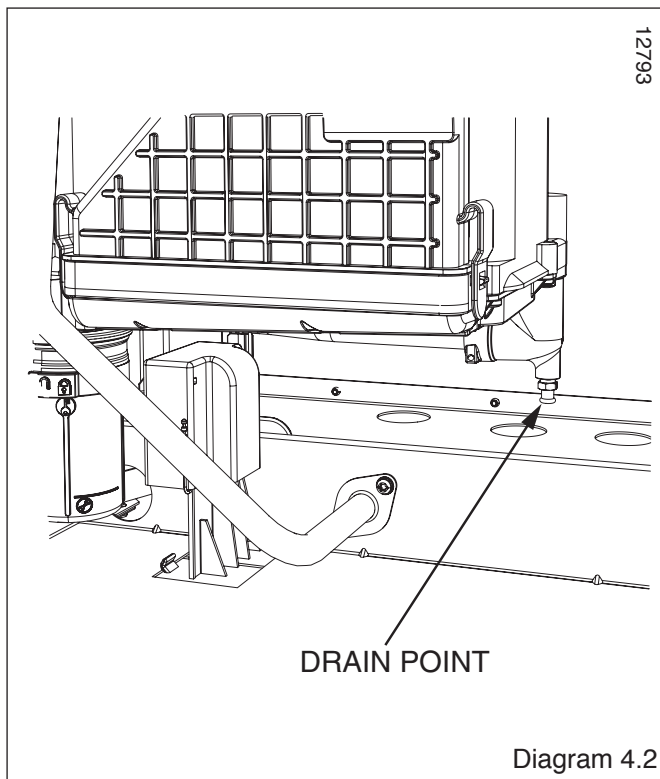

4 Water System

4.12 Safety Valve

A safety valve must be fitted to a sealed system. It shall be preset, non-adjustable with a lift pressure of 3 bar, incorporating seating of a resilient material, a test device and a connection for drain. The drain from the safety valve must be routed outside the building, must not discharge above an entrance or window or any type of public access area, be clear of any electrical fittings and positioned so that any discharge can be seen.

4.13 Expansion Vessel

A diaphragm type expansion vessel, conforming to the current issue of BS4814 (see also BS7074 Part 1 and 2) must be connected at a point close to the inlet side of the circulating pump, see the diagrammatic layout, diagram 4.3 unless laid down differently by the manufacturer. The expansion vessel volume depends on the total water system volume and the initial system design pressure. For any system an accurate calculation of vessel size is given in the current issue of BS5449 and BS7074 Part 1. Example: For an initial design pressure of 0.7 bar, the minimum total vessel volume required is $0.063 \times \text{Total System Volume}$.

NOTE: A higher initial design pressure requires a larger volume expansion vessel. Guidance on vessel sizing is also given in the current issue of BS5449 and BS7074 Part 1, for IE refer to the current edition of I.S.813 "Domestic Gas Installations". The charge pressure must not be less than the static head of the system, that is, the height of the highest point of the system above the expansion vessel.

4.14 Pressure Gauge

A pressure gauge with a set pointer and covering at least 0 to 4 bar (0 to 60 lb/in²) shall be fitted permanently to the system in a position where it can be seen when filling the system.

4.15 Domestic Hot Water Cylinder

SINGLE FEED INDIRECT CYLINDERS ARE NOT SUITABLE. The domestic hot water cylinder must be of the double feed fully indirect coil type. It must be suitable for working at a gauge pressure of 0.35 bar above the safety valve setting.

4.16 Water Makeup

Provision should be made for replacing water loss from the system using a make up bottle mounted in a position higher than the top point of the system, connected through a non-return valve to the return side of either the heating circuit or the hot water cylinder. Alternatively, provision for make up can be made using a filling loop.

4.17 Filling a Sealed Water System

Provision for filling the system at low level must be made, see diagram 4.4. There must be no permanent connection to the mains water supply, even through a non-return valve.

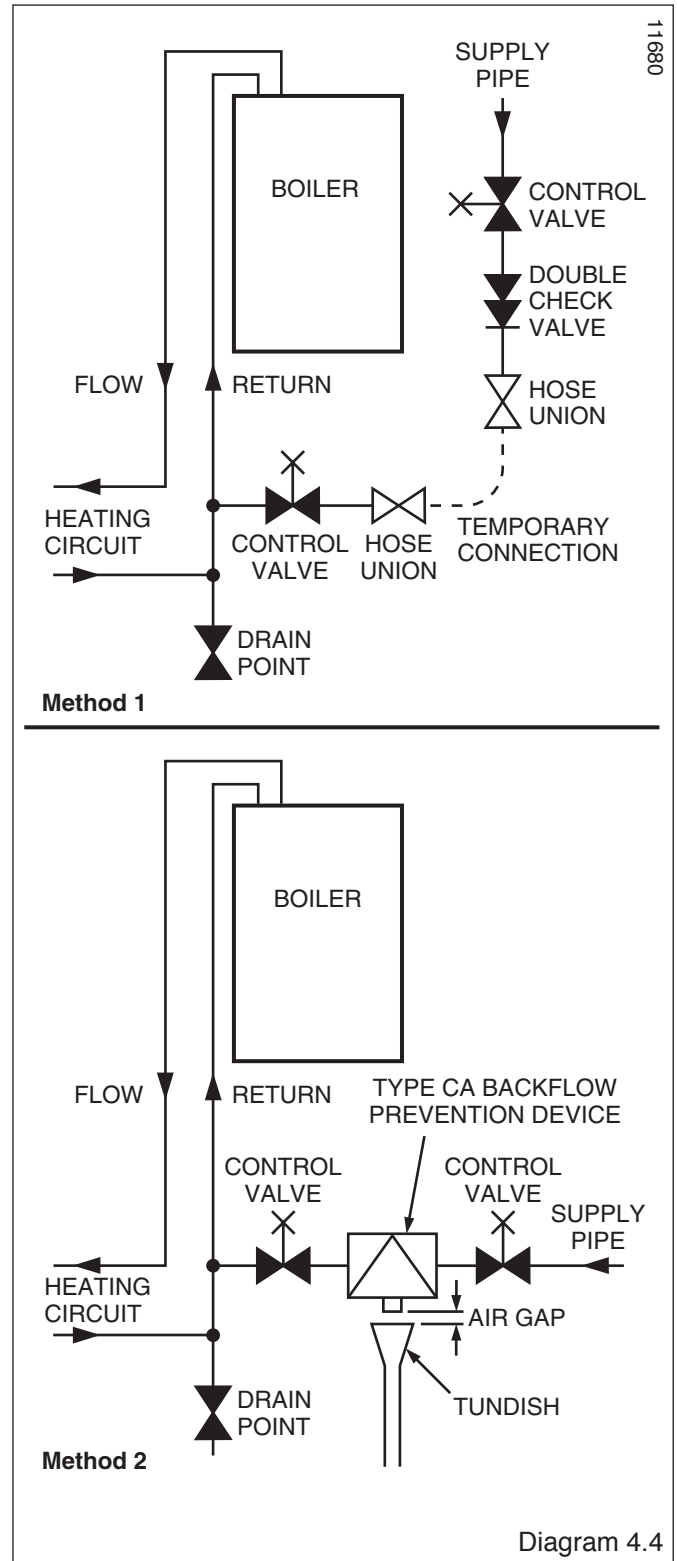

5 Installation Preparation

5.1 Appliance Fixings and Fittings

IMPORTANT: With regards to the Health and Safety Manual Handling requirements, the following lift operation is deemed to be a one person lift, refer to section 16 Manual Handling. The fixings, fittings and documentation pack are contained in the top polystyrene packing and should be as shown in diagram 5.1.

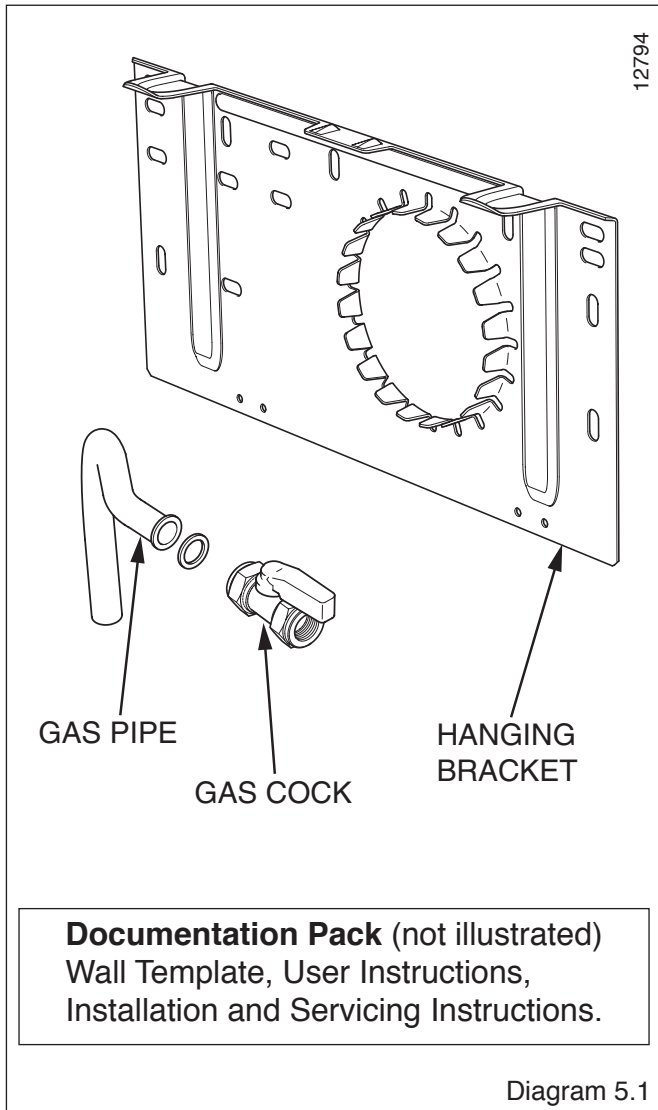

5.2 Wall Template

Take the wall template from the documentation pack located within the top polystyrene packing and place in the desired position on a flat wall, giving due consideration to boiler clearances, see section 2, and the flue you are fitting.

5.3 Flue Hole Cutting

External access flue installation can use a 105mm diameter core drill.

Internal access only flue installation will need a 125mm diameter core drill.

If flue extension pipes are to be used then a core drill size of 125mm is required. This will allow the extension pieces to slope at 44mm/metre (2.5°) towards the boiler.

Top horizontal flue - (standard and telescopic)

The standard horizontal flue is designed with an internal fall of 44mm/metre (2.5°) towards the boiler for disposal of condensate therefore the hole can be drilled horizontally. If the standard flue length alone is being used then the flue hole of diameter 105mm can be cut in the position marked on the wall template.

For standard side flues the horizontal flue centre line on the wall template should be extended to the side wall, and the vertical centre of the flue hole marked at 176mm from the back wall.

For extended side flues, the flue hole centre should be determined by extending the dashed inclined line on the template to the side wall. This dashed line is drawn at 44mm/metre (2.5°) rise from the boiler. Where this line reaches the side wall, a horizontal line should be marked. The vertical centre line of the flue should then be marked at 176mm from the back wall.

To allow for the flue passing through the wall at this angle a 125mm hole should be drilled irrespective of internal or external installation.

Remove the wall template whilst drilling the flue hole.

5.4 Flue Hole Cutting (rear flue - telescopic)

The rear flue is designed with an internal fall of 44mm/metre towards the boiler for disposal of condensate therefore the hole can be drilled horizontally. For installations with external access, a 105mm diameter core drill can be used.

6 Boiler Fixing

6.1 Hanging Bracket

Reposition the wall template over the flue hole and mark the position of the fixing holes for the hanging bracket, see diagram 6.1.

NOTE: Due to the varied site conditions we do not supply fixings and advise that the installer should supply those which are suitable.

Drill fixing holes and insert suitable wall plugs.

Rear Flue only - If external access is not available the flue to be used should be assembled as described in section 9 and inserted through the hole in the wall before fitting the wall hanging bracket.

6.2 Boiler Fixing

IMPORTANT: With regards to the Manual Handling Operations, 1992 regulations, the following lift operation is deemed to be a one person lift, refer to section 16 Manual Handling.

NOTE: If fitting a rear flue this must be fitted before hanging the boiler, refer to section 9.15.

Lift the boiler and position onto the mounting lugs.

Push the boiler firmly towards the wall to locate over the retaining bosses at the top centre of the fixing plate, see diagram 6.2.

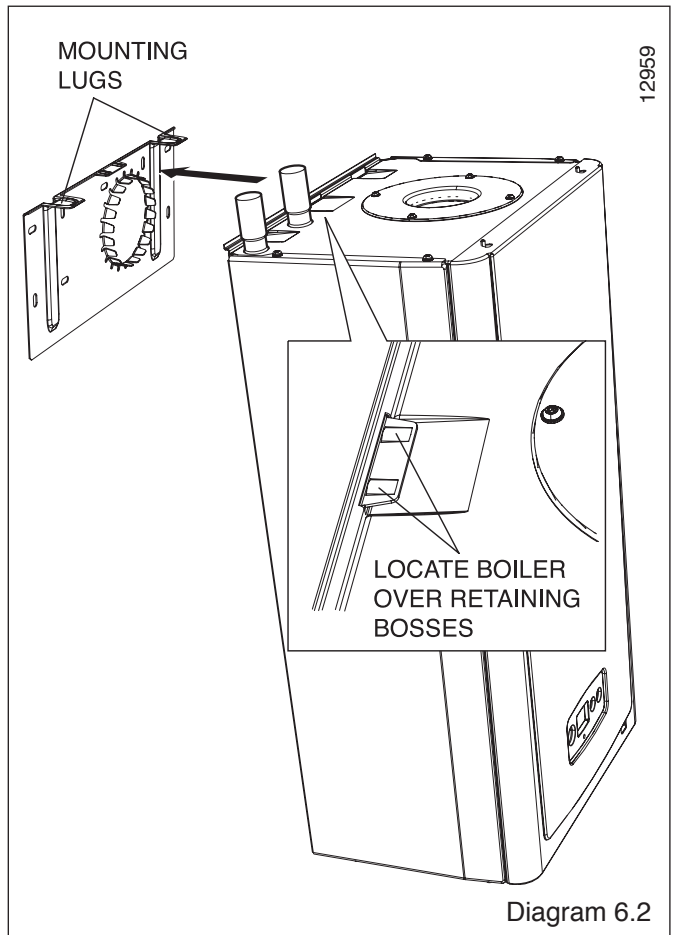
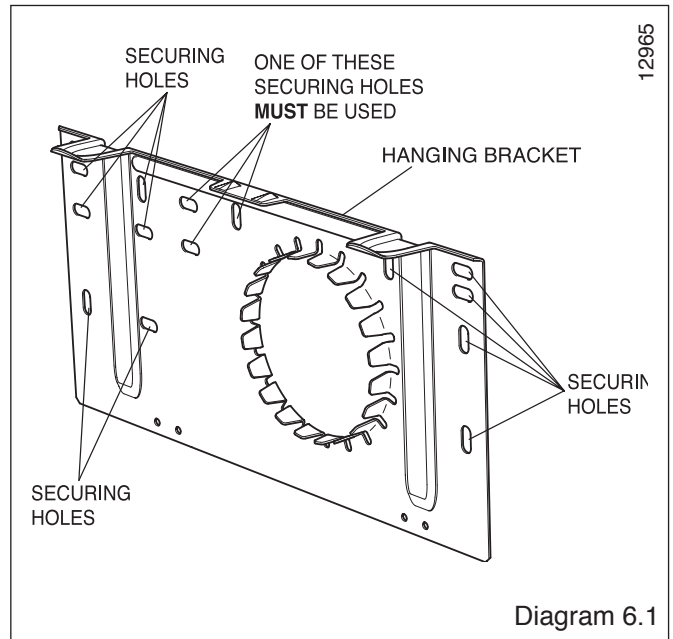

7 Gas / Water & Appliance Connection

7.1 Gas Connection

Before connection check the supply of local gas.
The gas supply can be connected from below, see diagram 7.1. or through the wall at the rear of the boiler.
Refer also to section 1.2 and 1.3.
The whole of the gas installation, including the meter, should be inspected, tested for soundness and purged in accordance with the current issue of BS6891 and in IE the current edition of I.S.813 "Domestic Gas Installations".

7.2 Water Connections

Provision is made for the water connections to be made from above the boiler, see diagram 7.1. The position is shown on the wall template.
Flush out the domestic hot water and the heating systems before connecting to the boiler.

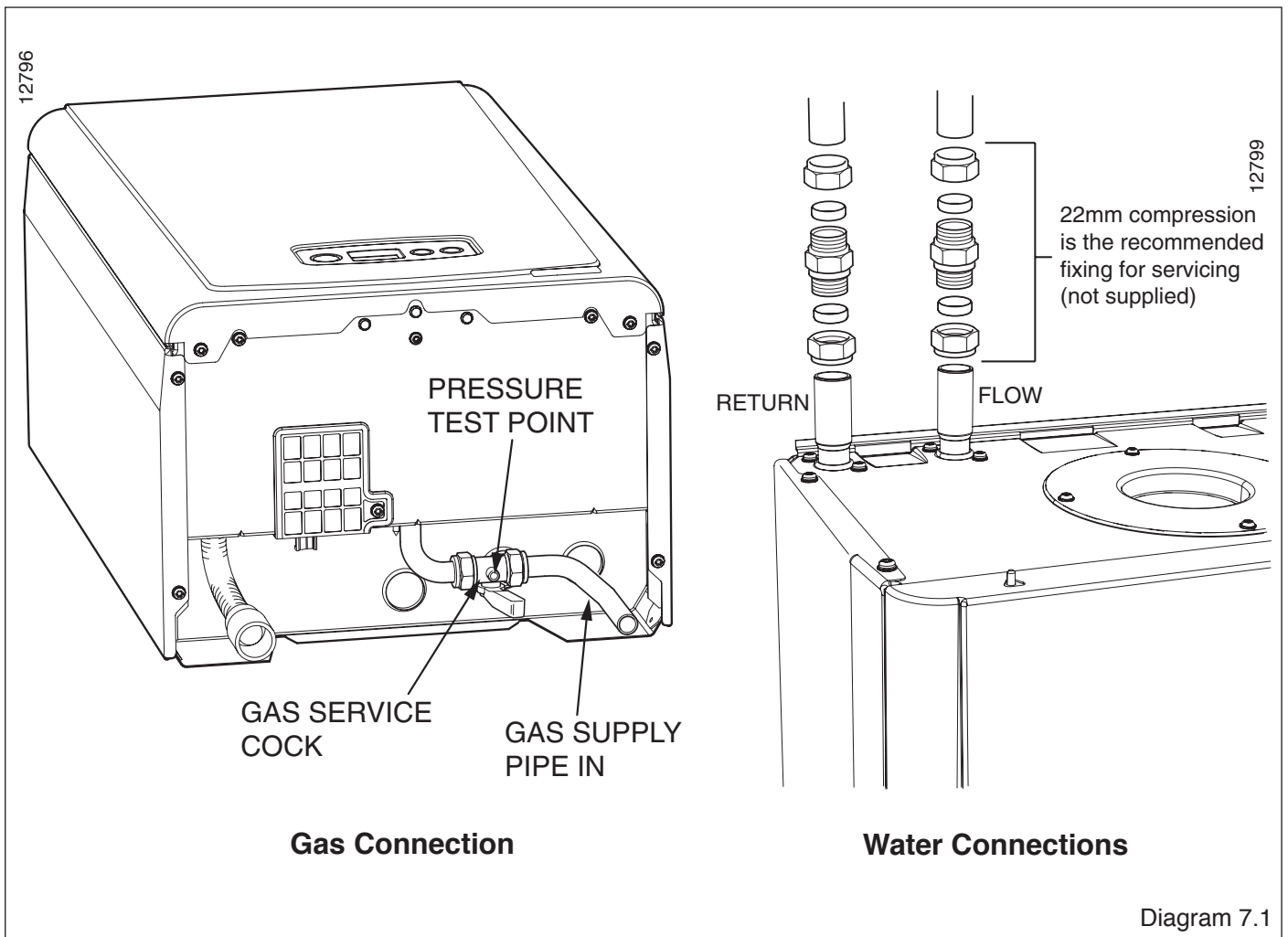

Diagram 7.1

8 Condensate Connections

8.1 Condensate Drain Connection

For condensate drain connection, see diagram 8.1. To discharge condensate to a drain, the drain pipe should have a fall of a least 44mm/metre (2.5°) away from the boiler.

Condensate should, if possible be discharged into the household internal drainage system. If this is not practicable, discharge can be allowed into the external household drains or a purpose designed soak away, refer to diagram 8.2.

It is recommended that any external condensate drain pipe is insulated and also preferably of 32mm diameter, to prevent freezing in adverse weather conditions.

The condensate is discharged periodically in 'slugs' by siphonic action.

It is not necessary to provide air breaks or extra traps in the discharge pipe as there is already a trap inside the boiler.

Fitting an extra trap may cause the boiler siphon to work incorrectly.

Refer to BS5546 or BS6798 for advice on disposal of boiler condensate.

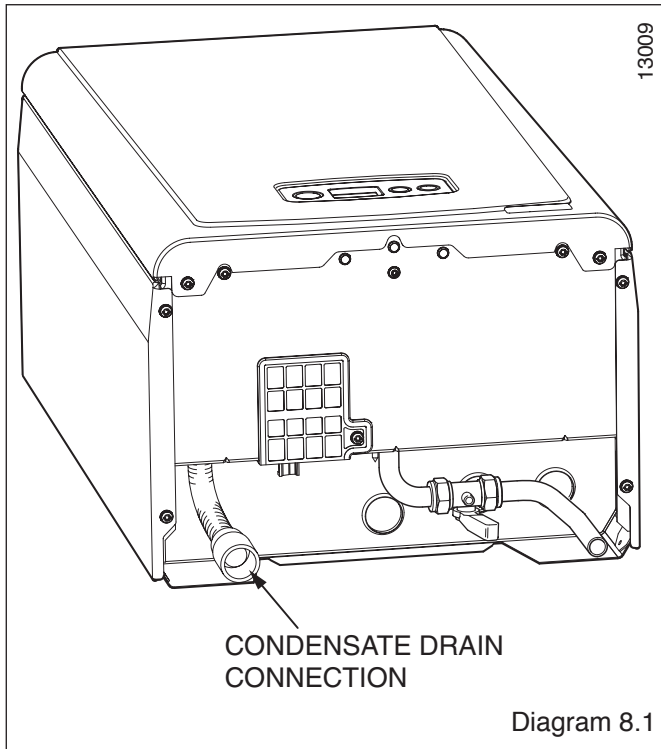

8 Condensate Connections

12333

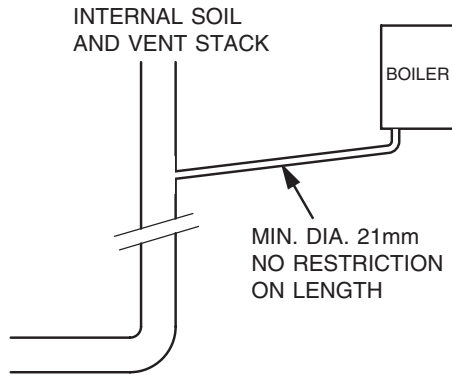

Internal Soil and Vent Pipe

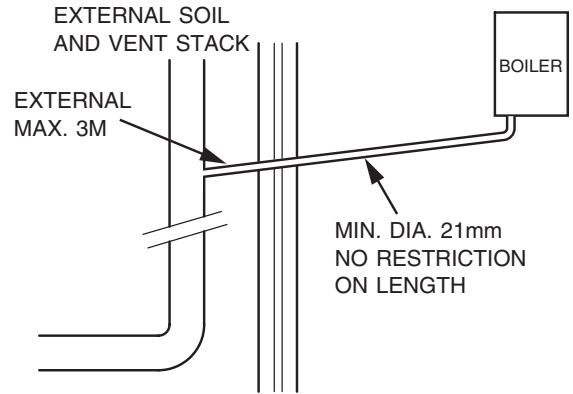

External Soil and Vent Pipe or Rainwater Pipe

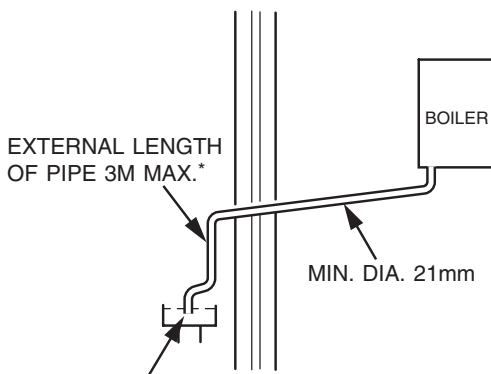

OPEN END OF PIPE DIRECT INTO GULLEY BELOW GROUND BUT ABOVE WATER LEVEL

*NOTE: FOR EXTENDED PIPE RUNS 32mm DIA. PIPE SHOULD BE USED.

External Termination to a Gully or Hopper

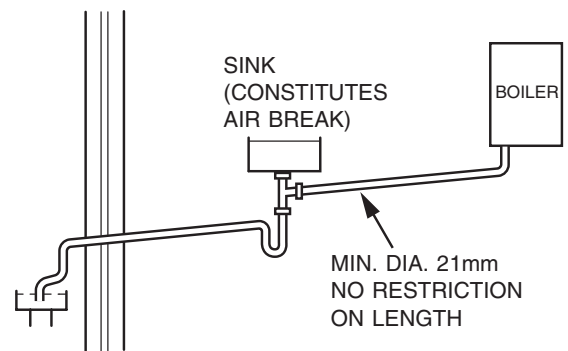

Internal Termination into Combined Sink Waste

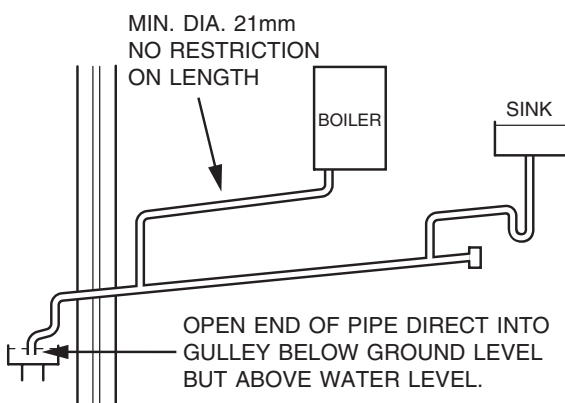

Internal Termination Downstream of Sink Waste

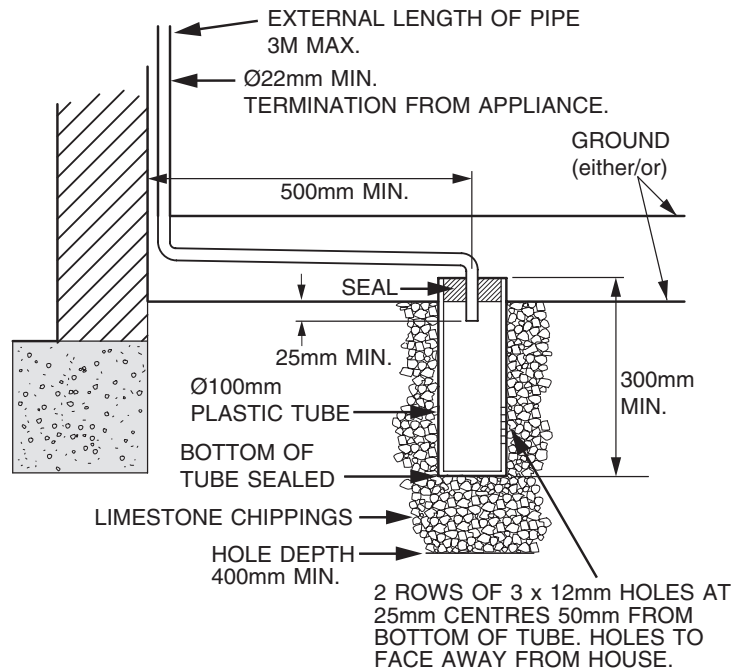

External Termination into Soakaway

NOTE: PIPEWORK SHOULD ALWAYS FALL AWAY FROM BOILER BY AT LEAST 2.5°
44mm FOR EVERY 1M.

Diagram 8.2

9 Flue Preparation and Installation

9.1 Top Horizontal Rear flue - Telescopic Part No. A2043600. Refer to diagram 9.1 for kit contents.

9.2 Flue Length

If a wall thickness of 232 min. to 437 max. is available the Top horizontal rear flue - telescopic can be used without extensions.

If the wall thickness is greater than 437 then using extensions a maximum horizontal flue length of 8 metres plus the Top horizontal rear flue - telescopic can be achieved. However, for every 90° or 45° elbows used the flue length MUST be reduced by 1 metre.

When extension pipes are used the flue system must be designed to have a continuous fall to the boiler of at least 44mm/metre (2.5°) to allow condensate to run back into the boiler and out via the drain.

9.3 Preparation

Remove the top flue outlet cover secured with four screws, see diagram 9.2.

Temporarily fit the flue elbow, measure the distance from the outside wall to flue elbow. If the measurement 'Y' exceeds 525mm, see diagram 9.3 then the appropriate length of extension pipe is required. If the dimension is less than 320mm DO NOT cut the flue, it can project beyond the outside wall face, see diagrams 9.4. If this is not desirable then a Top horizontal rear flue - standard MUST be used and cut to length.

9.4 Flue Fitting

Set the flue to the required length 'Y', ensure the air duct seams line up.

Remove the flue elbow.

Mark the securing hole position in the air duct. Drill a 3mm diameter hole at this position, take care not to pierce the inner flue duct. Secure with screw provided and tape the joint, see diagram 9.5.

Fit the sealing collar onto the locating ring on the flue terminal, see diagram 9.6.

Push the flue assembly into the wall, externally or internally, until the end of the assembly protrudes a short way from the inside face of the wall. This will enable the internal trim ring (if required) to be positioned and allow the flue assembly to be drawn back up to the flue elbow.

Secure the flue elbow in position on top of the boiler with four torque headed screws supplied.

Draw the flue assembly from wall and engage the flue duct into the elbow and butt fit between the air duct and flue elbow.

Ensure the correct alignment of the flue.

Fit the securing collar in position, mark through two of the pre drilled holes in the securing collar. Remove securing collar and drill two 3mm diameter holes one in the elbow and one in the air duct, take care not to pierce the inner flue duct. Fit the securing collar and secure with screws provided, see diagram 9.7.

Slide the internal trim ring back against the wall, securing in place with a small amount of sealant if required.

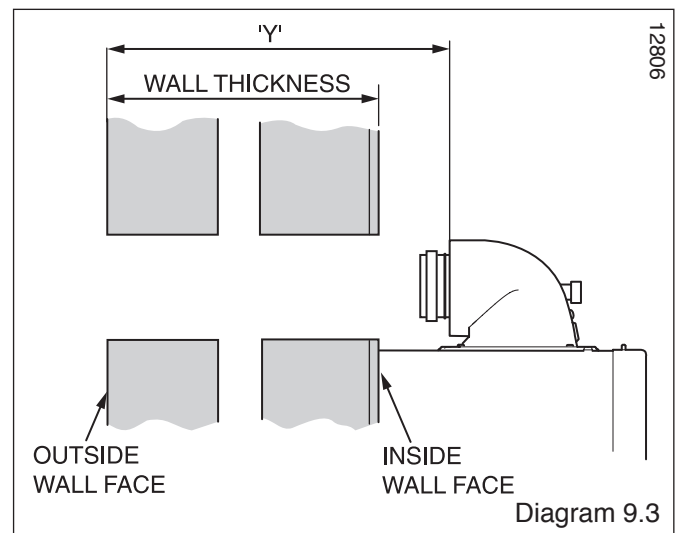
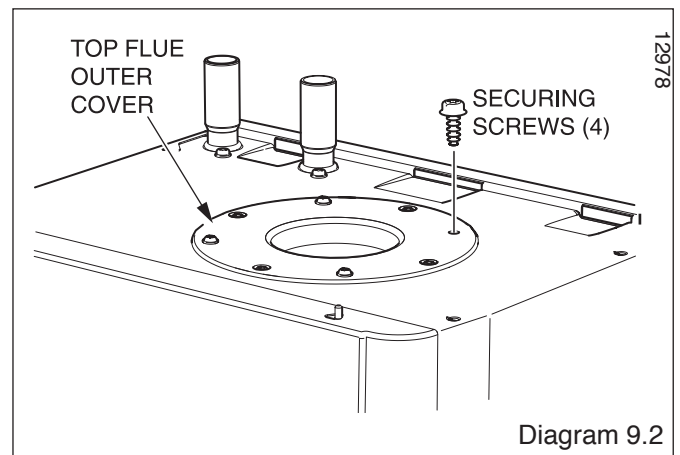
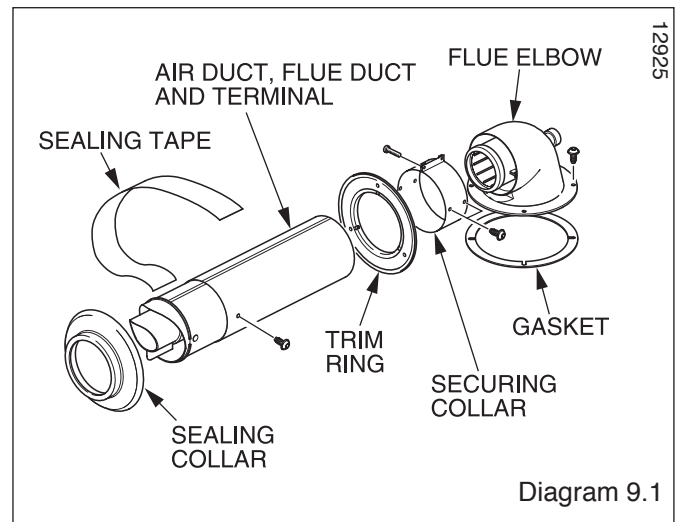

9 Flue Preparation and Installation

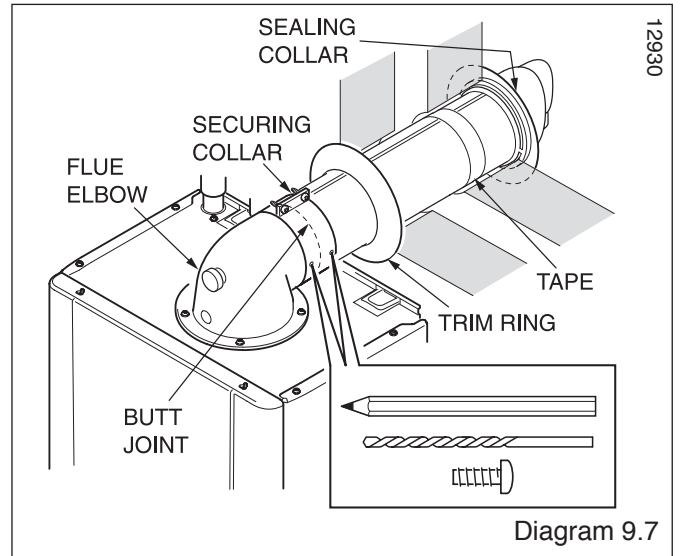
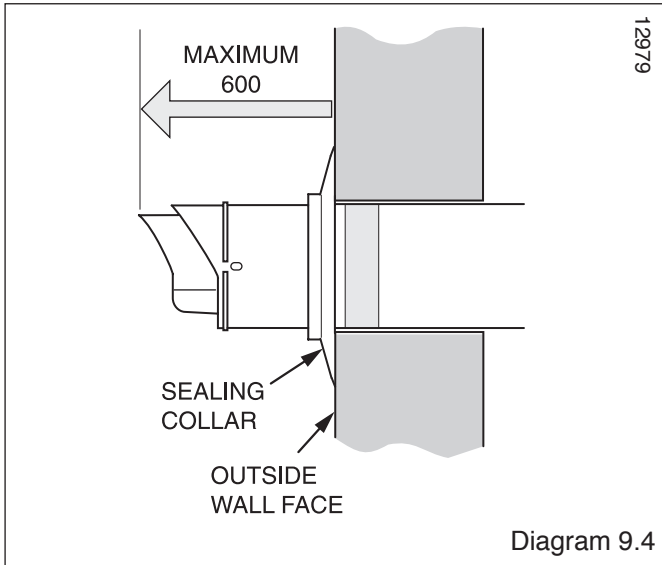

9.5 Top Horizontal Rear flue - Standard Part No. A2043400. Refer to diagram 9.8 for kit contents.

9.6 Flue Length

If a wall thickness of 75 min. to 507 max. is available the Top horizontal rear flue - standard can be used without extensions.

If the wall thickness is greater than 507 then using extensions a maximum horizontal flue length of 8 metres plus the Top horizontal rear flue - standard can be achieved. However, for every 90° or 45° elbows used the flue length MUST be reduced by 1 metre.

When extension pipes are used the flue system must be designed to have a continuous fall to the boiler of at least 44mm/metre (2.5°) to allow condensate to run back into the boiler and out via the drain.

Remove the top flue outlet cover secured with four screws, see diagram 9.2.

Temporarily fit the flue elbow, measure the distance from the outside wall to flue elbow. If the measurement 'Y' exceeds 652mm, then the appropriate length of extension pipe is required. The minimum dimension is 187 to suit a 75 min. wall thickness, see diagram 9.3.

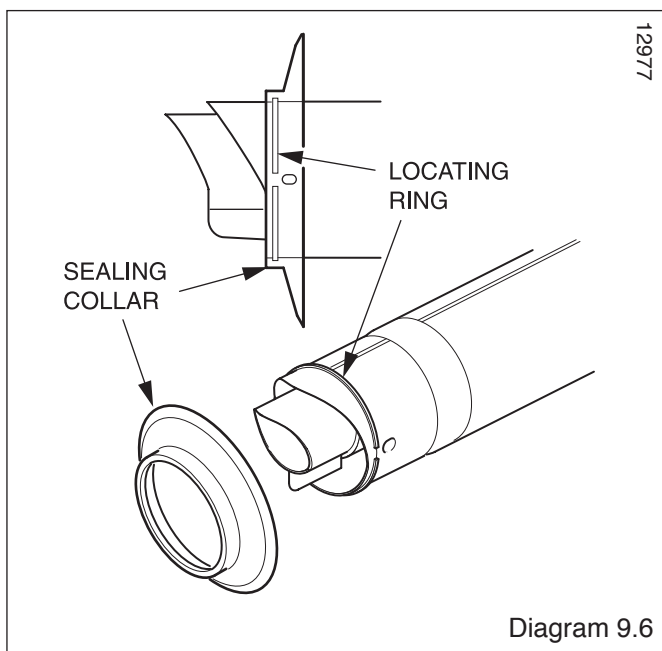
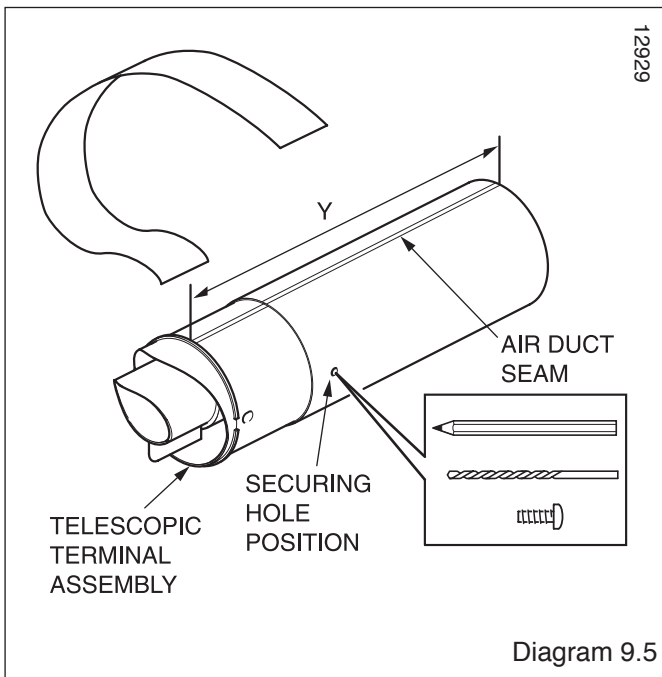

9.7 Flue Fitting

Remove the flue elbow.

Separate the flue duct from the terminal by twisting to release the terminal catch, then pull out of the retaining seal, refer to diagram 9.9.

The flue duct cutting length (L + 11mm.) is shown in diagram 9.9.

The air duct should be cut at the opposite end to the terminal

The plastic flue duct MUST be cut at the opposite end to the terminal catch.

The plastic flue duct extensions MUST be cut at the opposite end to the seal.

9 Flue Preparation and Installation

The cut ducts must be de-burred and all filings and debris removed.

Insert the flue duct into the air duct terminal assembly, remembering to engage the catch within the terminal.

NOTE: If you require to lubricate the seals to ease installation, please do not use a mineral oil based grease, we would recommend the use of water.

Fit the sealing collar onto the locating ring on the flue terminal, see diagram 9.6.

Push the flue assembly into the wall, externally or internally, initially until the end of the assembly protrudes a short way from the inside face of the wall. This will enable the internal trim ring (if required) to be positioned and allow the flue assembly to be drawn back into the flue elbow.

Secure the flue elbow in position on top of the boiler with four torque headed screws supplied.

Draw the flue assembly from wall and engage the flue duct into the elbow and butt fit between the air duct and flue elbow.

Ensuring the correct alignment of the terminal.

Fit the securing collar into position, mark through two of the pre drilled holes in the securing collar. Remove securing collar and drill two 3mm diameter holes one in the elbow and one in the air duct, take care not to pierce the inner flue duct. Fit the securing collar and secure with screws provided, see diagram 9.10.

Slide the internal trim ring back against the wall, securing in place with a small amount of sealant if required.

NOTE: If the air and flue ducts have been correctly cut to the instructions given, the sealing collar should fit flush with the outside wall, check this.

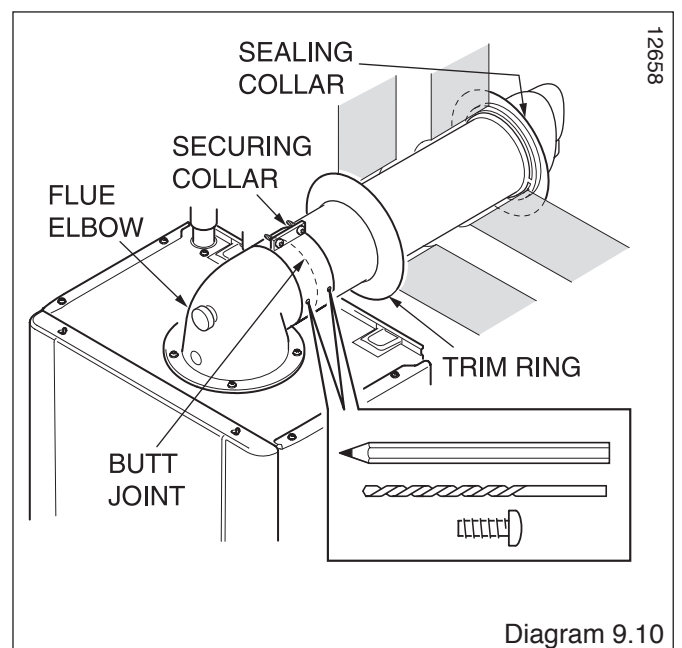
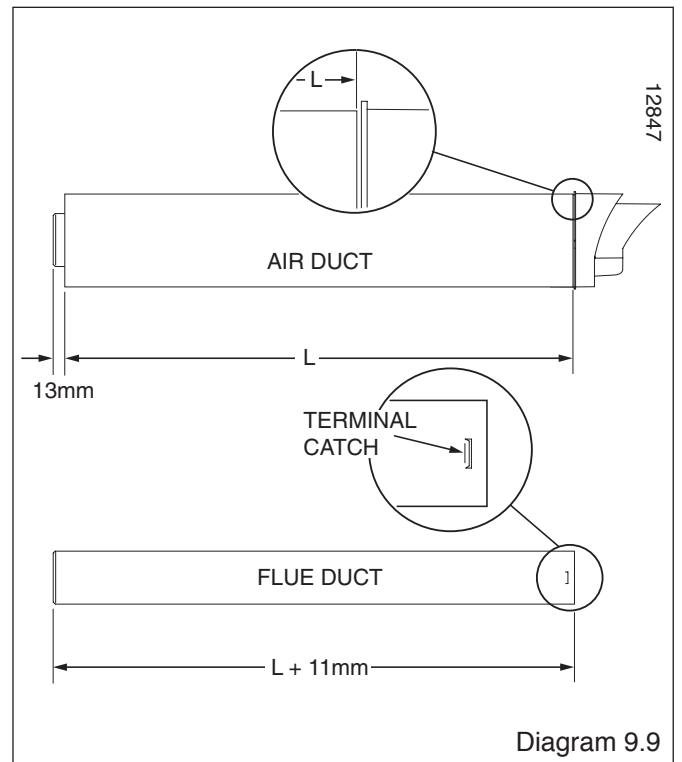
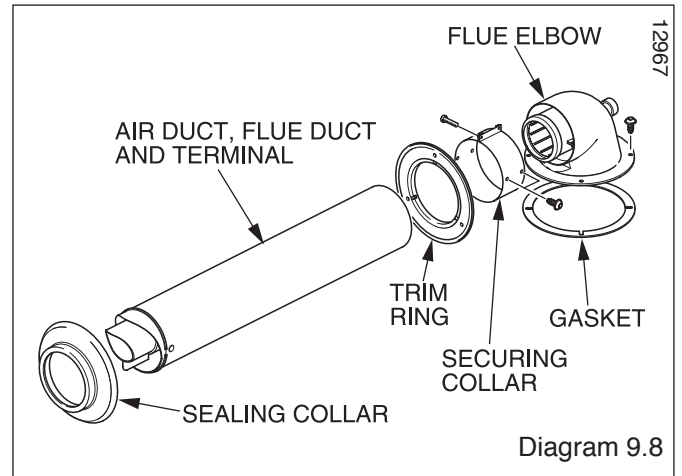

9 Flue Preparation and Installation

9.8 Top Horizontal Side flue - Telescopic Part No. A2043600. Refer to diagram 9.1 for kit contents.

9.9 Flue Length

The maximum permissible horizontal flue length is 8 metres plus the Top horizontal side flue - telescopic. This can be achieved by the use of the extensions, however, for every 90° or 45° elbows used the flue length MUST be reduced by 1 metre.

When extension pipes are used the flue system must be designed to have a continuous fall to the boiler of at least 44mm/metre (2.5°) to allow condensate to run back into the boiler and out via the drain.

9.10 Preparation

Remove the top flue outlet cover secured with four screws, see diagram 9.2.

Temporarily fit the flue elbow, measure the distance from the outside wall to flue elbow. If the measurement 'Y' exceeds 525mm, see diagram 9.11 then the appropriate length of extension pipe is required. If the dimension is less than 320mm DO NOT cut the flue, it can project beyond the outside wall face, see diagrams 9.4. If this is not desirable then a Top horizontal side flue - standard MUST be used and cut to length.

9.11 Flue Fitting

Set the flue to the required length 'Y', ensure the air duct seams line up.

Remove the flue elbow.

Mark the securing hole position in the air duct. Drill a 3mm diameter hole at this position, take care not to pierce the inner flue duct. Secure with screw provided and tape the joint, see diagram 9.5.

Fit the sealing collar onto the locating ring on the flue terminal, see diagram 9.6.

Push the flue assembly into the wall, externally or internally, until the end of the assembly protrudes a short way from the inside face of the wall. This will enable the internal trim ring (if required) to be positioned and allow the flue assembly to be drawn back up to the flue elbow.

Secure the flue elbow in position on top of the boiler with four torque headed screws supplied.

Draw the flue assembly from wall and engage the flue duct into the elbow and butt fit between the air duct and flue elbow.

Ensure the correct alignment of the flue.

Fit the securing collar in position, mark through two of the pre drilled holes in the securing collar. Remove securing collar and drill two 3mm diameter holes one in the elbow and one in the air duct, take care not to pierce the inner flue duct. Fit the securing collar and secure with screws provided, see diagram 9.12.

Slide the internal trim ring back against the wall, securing in place with a small amount of sealant if required.

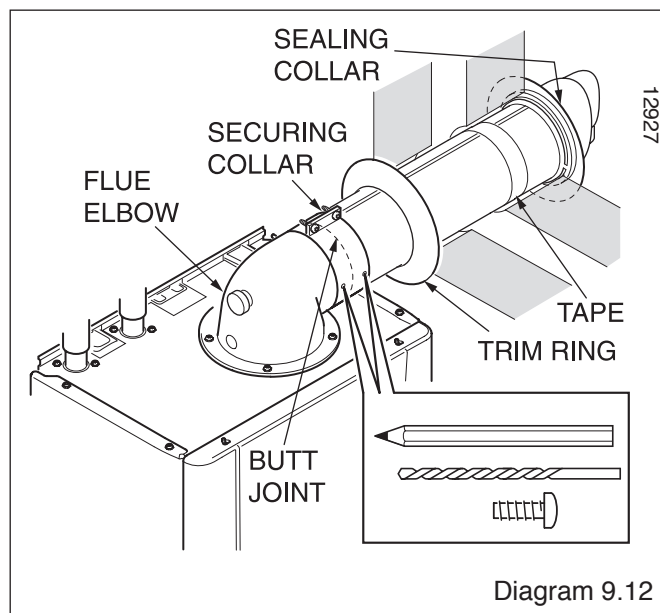
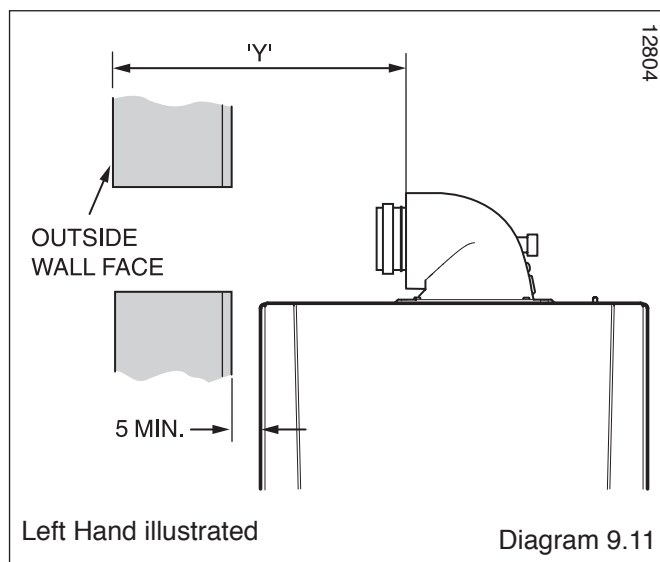

9 Flue Preparation and Installation

9.12 Top Horizontal Side flue - Standard Part No. A2043400. Refer to diagram 9.8 for kit contents.

9.13 Flue Length

Remove the top flue outlet cover secured with four screws, see diagram 9.2.

Temporarily fit the flue elbow, measure the distance from the outside wall to flue elbow. If the measurement 'Y' exceeds 652mm, then the appropriate length of extension pipe is required. The minimum dimension for LH is 270 and RH 242 to suit a minimum wall thickness of 75mm, see diagram 9.11.

9.14 Flue Fitting

Remove the flue elbow.

Separate the flue duct from the terminal by twisting to release the terminal catch, then pull out of the retaining seal, refer to diagram 9.9.

The flue duct cutting length ($L + 11\text{mm.}$) is shown in diagram 9.9.

The air duct should be cut at the opposite end to the terminal

The plastic flue duct **MUST** be cut at the opposite end to the terminal catch.

The plastic flue duct extensions **MUST** be cut at the opposite end to the seal.

The cut ducts must be de-burred and all filings and debris removed.

Insert the flue duct into the air duct terminal assembly, remembering to engage the catch within the terminal.

NOTE: If you require to lubricate the seals to ease installation, please do not use a mineral oil based grease, we would recommend the use of water.

Fit the sealing collar behind the locating lugs on the flue terminal, see diagram 9.6.

Push the flue assembly into the wall, externally or internally, initially until the end of the assembly protrudes a short way from the inside face of the wall. This will enable the internal trim ring (if required) to be positioned and allow the flue assembly to be drawn back into the flue elbow.

Secure the flue elbow in position on top of the boiler with four torque headed screws supplied.

Draw the flue assembly from wall and engage the flue duct into the elbow and butt fit between the air duct and flue elbow.

Ensuring the correct alignment of the terminal.

Fit the securing collar into position, mark through two of the pre drilled holes in the securing collar. Remove securing collar and drill two 3mm diameter holes one in the elbow and one in the air duct, take care not to pierce the inner flue duct. Fit the securing collar and secure with screws provided, see diagram 9.12.

Slide the internal trim ring back against the wall, securing in place with a small amount of sealant if required.

NOTE: If the air and flue ducts have been correctly cut to the instructions the sealing collar should fit flush with the outside wall, check this.

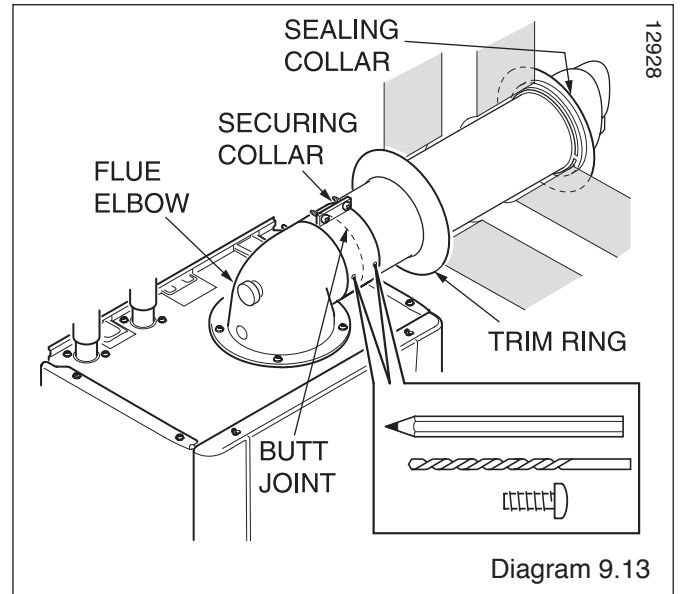

9 Flue Preparation and Installation

9.15 Rear flue - Telescopic Part No. A2043500. Refer to diagram 9.14 for kit contents.

9.16 Flue Length

Measure the distance from the outside wall to the inside wall face. This measurement must not exceed 512mm. if the dimension is less than 291mm DO NOT cut the flue, it can project to its maximum.

9.17 Flue Fitting

Set the flue to the required length 'Y' plus 24mm MIN to 28mm MAX, see diagram 9.16, ensure the air duct seams line up. Mark the securing hole position in the air duct. Drill a 3mm diameter hole at this position, take care not to pierce the inner flue duct. Secure with screw provided and tape the joint, see diagrams 9.14 and 9.15.

Fit the sealing collar onto the locating ring on the flue terminal, see diagram 9.6.

Push the telescopic terminal assembly into the wall, externally or internally, initially.

Draw the telescopic flue through the wall and engage the telescopic terminal assembly into the clamping band grips. The telescopic terminal assembly must be pulled forward of the clamping band grips by the dimension shown in diagram 9.16 to ensure a good seal when the boiler is located onto the fixing plate.

Ensuring the correct alignment of the terminal.

Secure the telescopic terminal assembly using the clamping band supplied. The position of the clamping band securing screw is important, refer to label and wall template.

IMPORTANT: CHECK THE CLAMPING BAND IS SUFFICIENTLY TIGHTENED TO AVOID ANY MOVEMENT OF THE FLUE WHEN FITTING THE BOILER.

Remove the rear flue outlet cover secured with four screws.

Fix the boiler to the wall, refer to Section 6 Boiler Fixing.

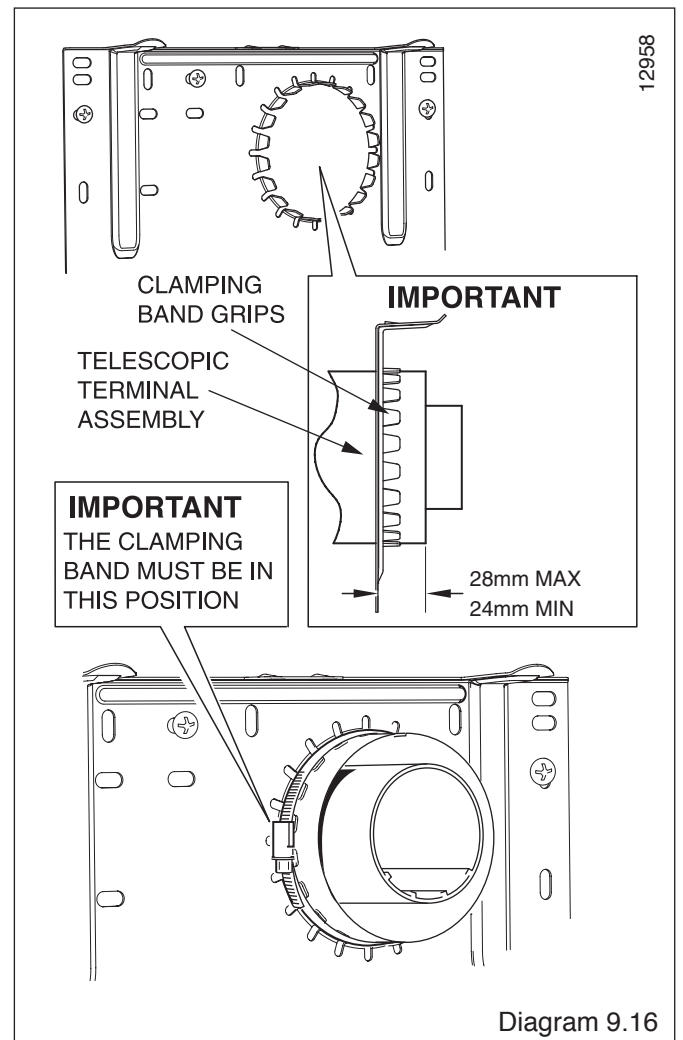
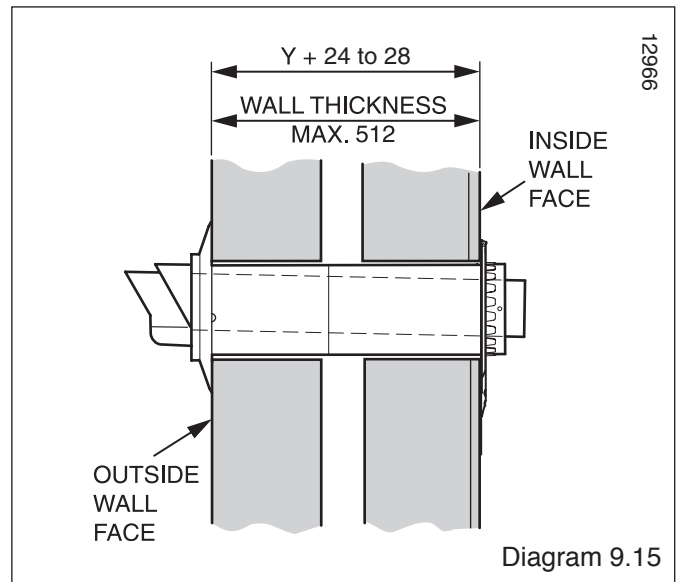
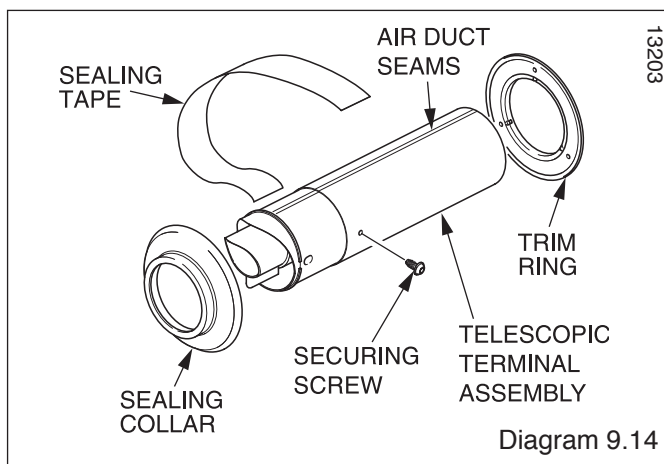

9 Flue Preparation and Installation

9.18 Vertical flue

The vertical flue system is available as an option where the boiler position does not permit the use of the top horizontal or rear flue system.

The system is made up of accessories. The accessories include terminal assembly, bends 45° and 90°, flue extensions, fixing bracket and appropriate weather collar, see diagram 9.17.

The maximum permitted straight flue length is 8 metres plus the terminal. for each 90° or 2x45° bends fitted, the maximum length must be reduced by 1 metre, see diagram 9.22.

NOTE: 2x45° bends can replace 1x90° bend if necessary. When using 90° bends any horizontal extension pipe should be inclined by a minimum of 44mm/metre (2.5°) towards the boiler to facilitate condense removal, see (a) in diagram 9.22.

Alternatively use 45° bends to avoid horizontal runs, see (b) in diagram 9.22.

The terminal should be positioned at least 600mm from any opening into the building, refer to diagram 3.2.

Measure the distance of flue length required for the installation.

The flue must be designed with a continuous fall towards the boiler.

Remove the top flue outlet cover secured with four screws, see diagram 9.2.

Refer to diagram 9.18. Secure the flue adapter in position on top of the boiler with four torx headed screws supplied, making sure the nib fits into the locating slot in the boiler casing to ensure correct orientation.

The rubber 'O' rings of each section should be lubricated prior to assembly.

NOTE: Do not use mineral oils or grease, silicon grease or water is recommended.

Secure the first extension pipe to the flue adapter with the securing collar supplied by positioning the collar centrally over the joint, then tighten the two screws on the securing collar, see diagram 9.19.

Fit more extension pipes as required using the collar and screws supplied with each extension pipe. To fit position the collar centrally over the joint, tighten the two screws on the securing collar. Using the holes provided in the securing collar drill and insert the two self tapping screws supplied, see diagram 9.20.

The rubber 'O' rings of each section should be lubricated prior to assembly.

NOTE: Do not use mineral oils or grease, silicon grease or water is recommended.

When building the flue up it is recommended that it is supported every 2 metres and at every bend by a fixing bracket.

Project the rise of the flue pipe to roof level and cut a 150mm hole in the roof.

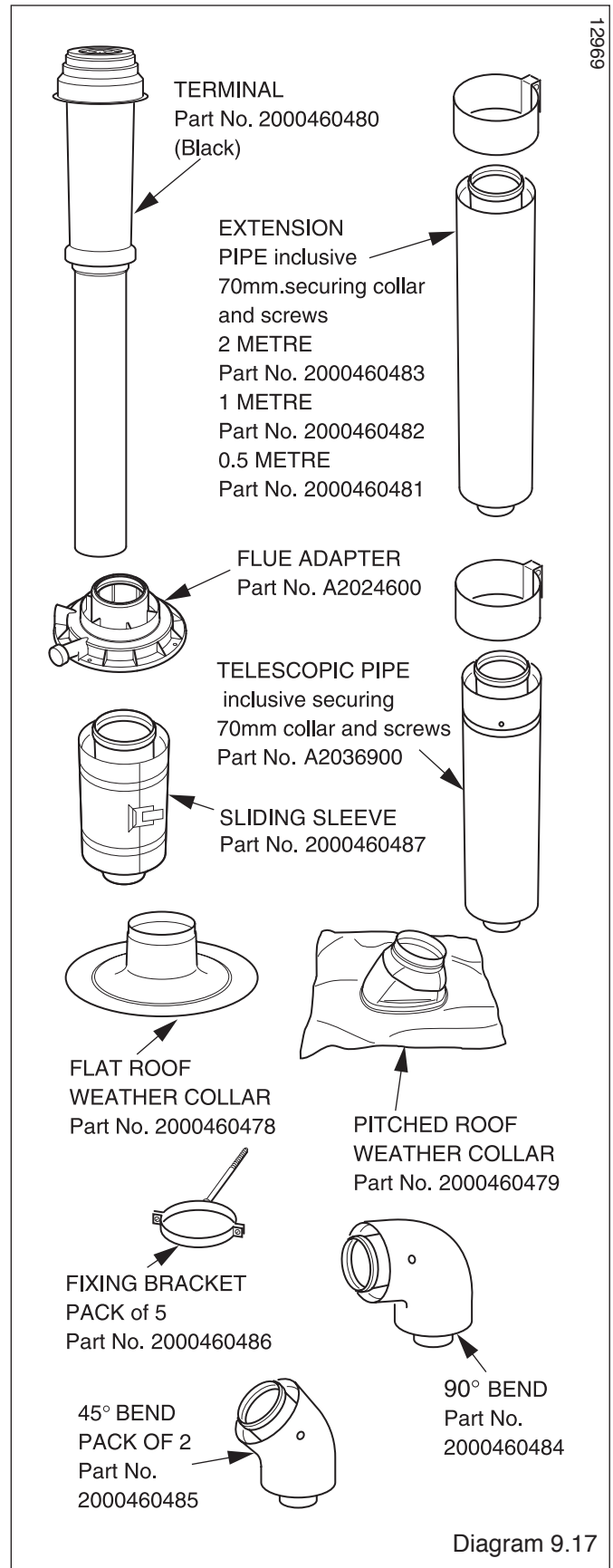

9 Flue Preparation and Installation

Flue Terminal Installation

(a) Pitched Roof

Fit the required pitched roof weather collar over the 150mm hole in the roof. Make good the tiling or slating around the collar incorporating the flashing of the weather collar. Position the angle cap over the weather collar in the correct orientation to attain the correct angle for your roof.

(b) Flat Roof

Fit the aluminium weather collar over the 150mm hole in the roof ensuring a weather tight seal.

From above carefully place the flue terminal through the weather collar.

Completion of Installation

With the flue terminal positioned in the roof the length of the final pipe can be determined. If a telescopic length cannot be used, then a standard flue length can be cut to make the correct length. Cut the flue to the desired length measuring from the 'O' ring end and discard the plain end of the tube. The cuts must be square and made free of burrs to allow correct assembly. (**NOTE:** The flue pipe is 10mm longer than the air pipe), see diagram 9.21. Carefully push the terminal assembly upwards to allow room for fitting the final flue piece. Fit a fixing bracket to the terminal assembly. Pull the terminal assembly down and join to the flue system. Ensure that the terminal is making a weather tight seal on the weather collar. Secure the fixing bracket fitted to the terminal to the roofing struts or a purpose made baton.

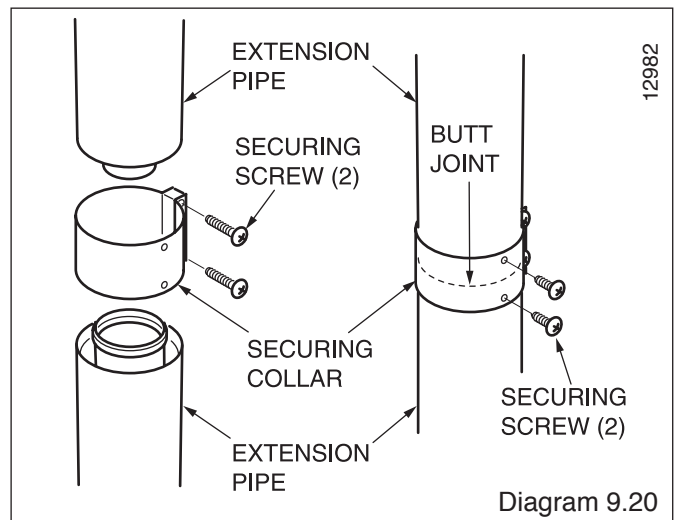
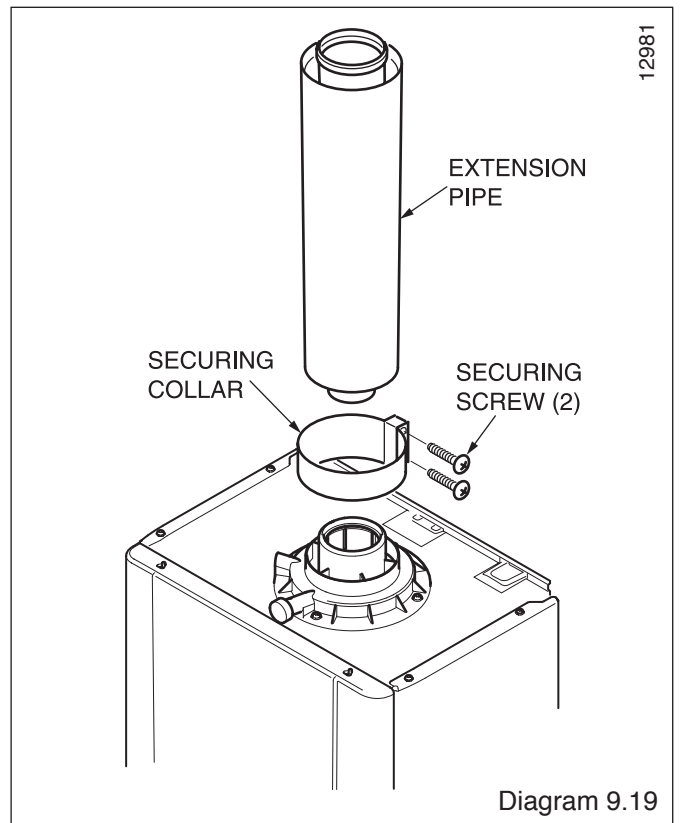
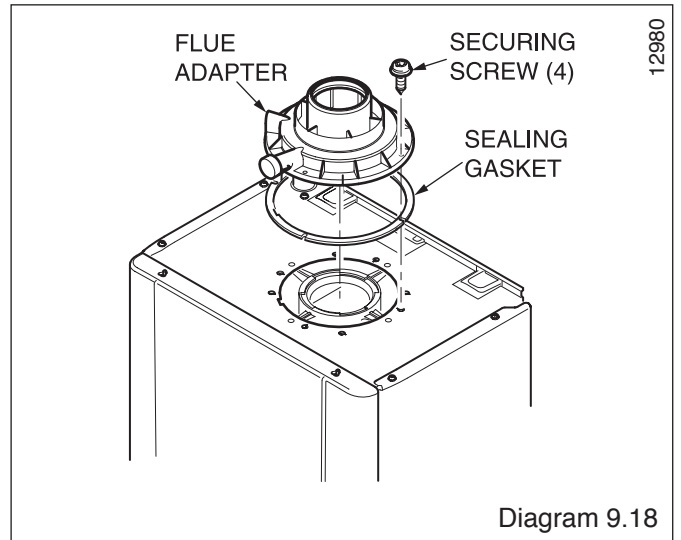

9 Flue Preparation and Installation

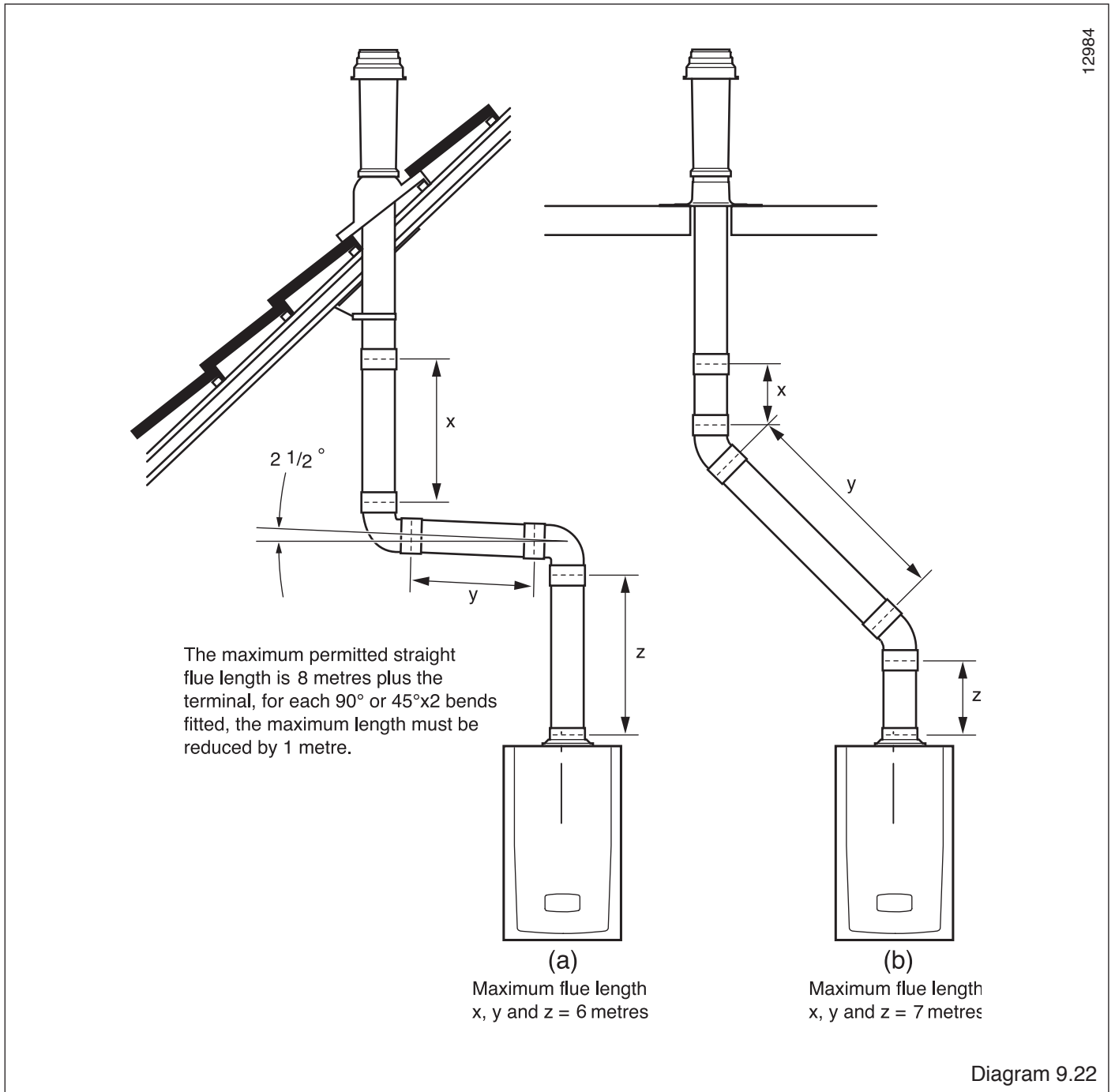
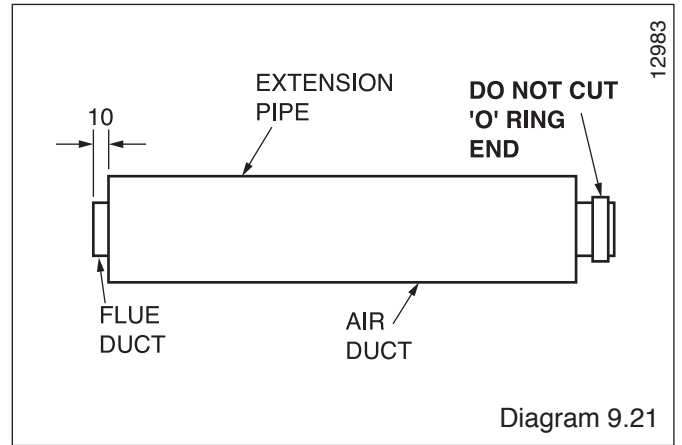

9 Flue Preparation and Installation

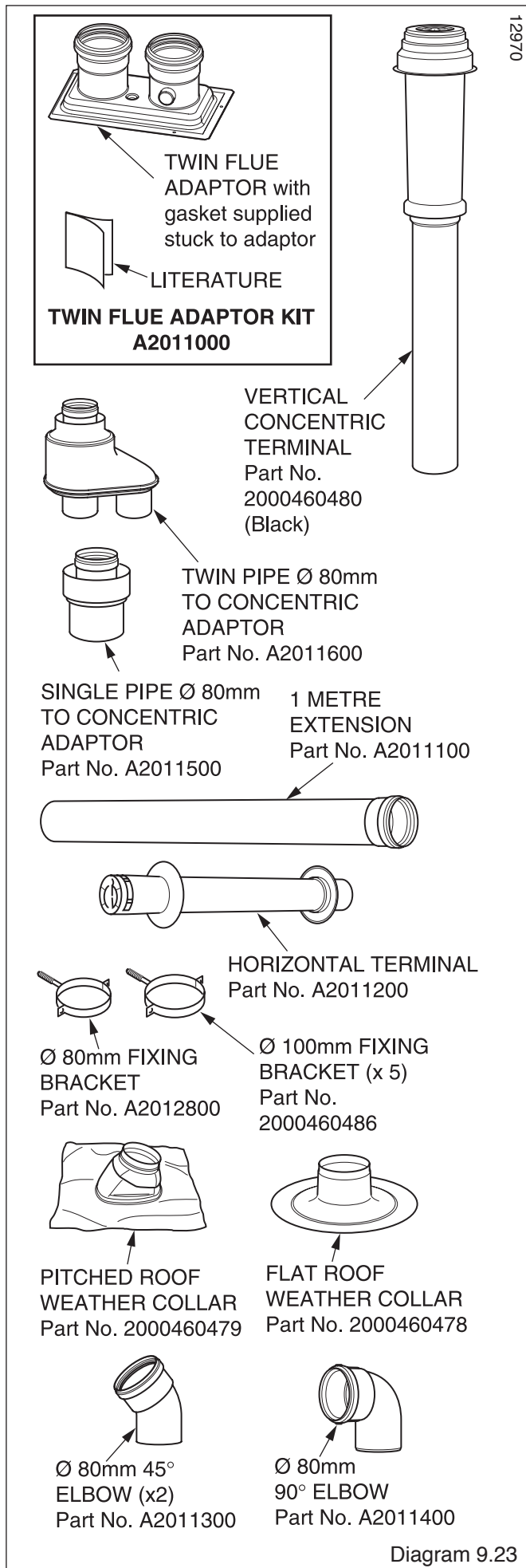

Diagram 9.23

9.19 Twin flue

The twin flue system is available as an option when the top horizontal, rear or vertical flue system is not appropriate.

The system can provide an independent horizontal air inlet and flue outlet, horizontal air inlet and vertical flue outlet or vertical air inlet and flue outlet via a concentric terminal.

NOTE: The air and flue outlets do not have to be equal lengths. 2x45° bends can replace 1x90° bend if necessary.

The maximum permitted straight pipe length is 20 metres plus terminal assemblies, for each 90° or 45° x 2 bends fitted, the maximum length must be reduced by 1 metre.

NOTE: When using 90° bends any horizontal run should be inclined by a minimum of 44mm/metre (2.5°) towards the boiler to facilitate condensate removal.

Alternatively use 45° bends to avoid horizontal runs in the flue pipe.

Terminal Position

The clearances for a flue outlet are given in the "Flue Location and Ventilation" section.

In addition the horizontal air inlet must not be closer than 300 mm from a flue outlet on the same wall or 1200mm from an opposing flue outlet.

Installation Details

The parts available for a twin flue system installation are shown in diagram 9.23.

Boiler Connection

Remove the top flue outlet cover secured with four screws, see diagram 9.2.

Push the twin flue adaptor onto the outlet of the boiler with the air inlet to the left hand side. Secure the adaptor to the top panel with the screws provided. Care should be taken when inserting the screw through the hole in adaptor top.

To facilitate engagement, it is recommended that the rubber 'O' rings are lubricated with silicone grease or water prior to assembly.

See diagram 9.24.

Air and Flue Pipe Installation

The air and flue pipes can now be built up from the boiler.

The flue must be designed with a continuous fall towards the boiler. If using the horizontal flue pipe or 90° bends the pipe must be inclined at 44mm/metre (2.5°) minimum, see diagram 9.25.

Alternatively if space allows, use 45° bends in place of 90° bends.

The rubber 'O' rings of each section should be lubricated prior to assembly with silicone grease.

When building the flue up it is recommended that it is supported every 2 metres and at every bend by a fixing bracket.

9 Flue Preparation and Installation

Horizontal Terminal Installation

With due consideration to terminal clearances mentioned in Section 3.2 drill the one or two holes as required with a 90mm core drill.

Push the horizontal terminal through the wall allowing approx. 100mm to protrude outside.

Push a grey rubber wall seal onto either side of the wall ensuring that both wall seals are pushed up to the wall surface, see examples (b) and (c) diagram 9.25.

Vertical Terminal Installation

With due consideration to terminal clearances mentioned in Section 3.2, project the rise of the flue pipe to roof level and cut 150mm hole in the roof.

(a) Pitched Roof

Fit the required pitched roof weather collar over the 150mm hole in the roof. Make good the tiling or slating around the collar incorporating the flashing of the weather collar. Position the angle cap over the weather collar in the correct orientation to attain the correct angle for your roof. One way round gives a pitch of 25°-38° and the other gives 37°- 50°.

(b) Flat Roof

Fit the aluminium weather collar over the 150mm hole in the roof ensuring a weather tight seal.

Horizontal Pipes-Completion of Installation

Having built the pipe(s) from the boiler to the terminal(s), the length of the final pipe piece can be determined. Cut pipes at the opposite end to the 'O' ring seal making square and free from burrs. Push the horizontal terminal through the wall to engage the final pipe piece and pull back ensuring the grey wall seals are fully pulled up to the outside and inside wall faces.

Vertical Pipes-Completion of Installation

Refer to diagram 9.25.

For installation of (a), attach the twin pipe to concentric flue adaptor, part number A2011600, to the base of vertical terminal assembly. For installation of (b), attach the single pipe to concentric adaptor, part number A2011500, to the base of vertical terminal assembly.

With the vertical terminal assembly positioned in the roof, the length of the final pipe can be determined. Cut the flue to the desired length measuring from the 'O' ring seal end and discard the plain end of the tube. The cut end should be square and free from burrs. Carefully push the terminal assembly upwards to allow room for fitting the final flue piece(s). Fit a 100mm fixing bracket to the terminal assembly Part No2000460486. Pull the terminal assembly down and join to the flue system. Ensure that the terminal is making a weather tight seal on the weather collar. Secure the fixing bracket fitted to the terminal to the roofing struts or a purpose made batton.

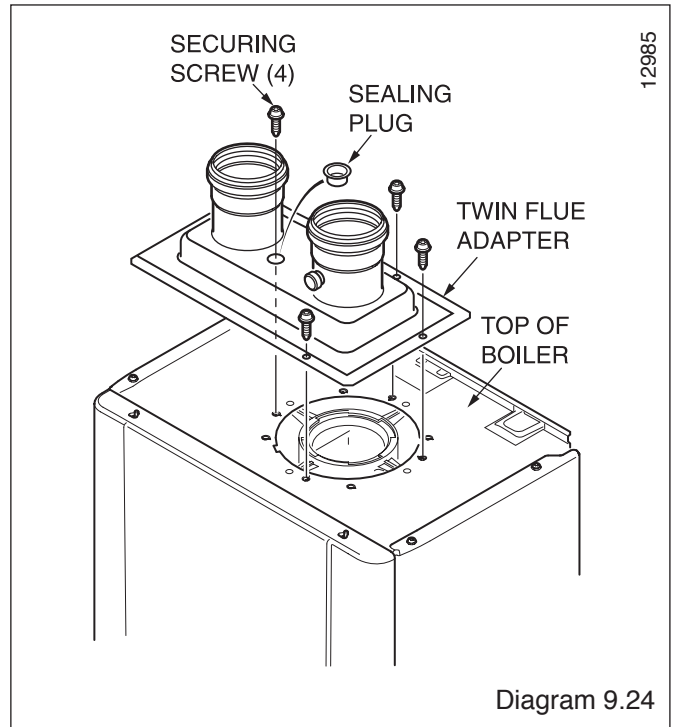

9 Flue Preparation and Installation

12987

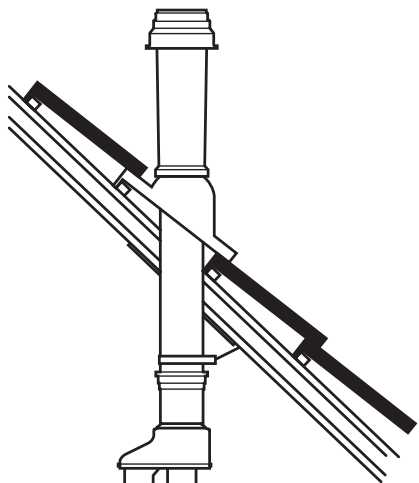

(a)

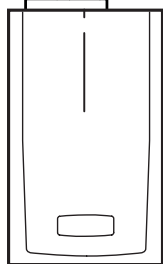

100 mm.
APPROX.

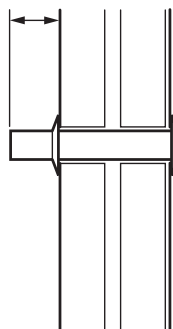

(b)

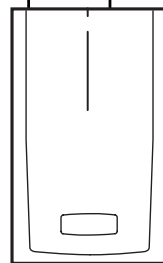

100 mm.
APPROX.

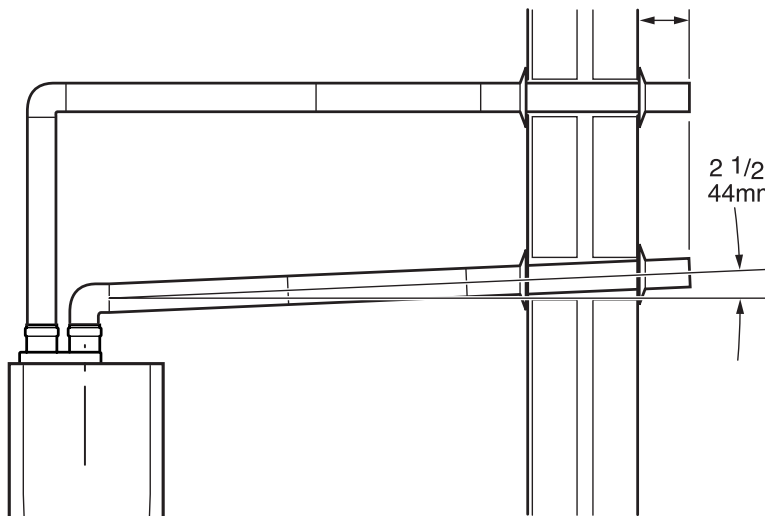

(c)

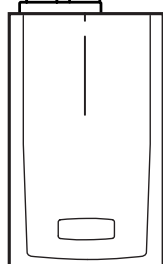

Diagram 9.25

9 Flue Preparation and Installation

12997

IMPORTANT: The flue outlet must not be positioned within 300mm from an opening, air brick or opening windows.

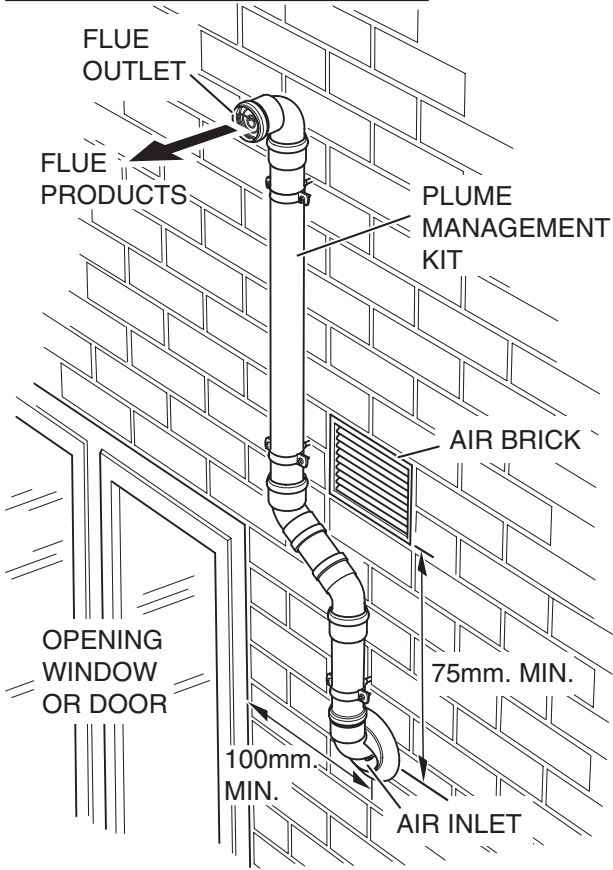

Diagram 9.26

9.20 Plume Management Kit

The Plume Management Kit: Part No. A2044100 (white) or A2044000 (black) can be used to overcome many site issues.

The Plume Management Kit will fit to the Top Horizontal Telescopic, Rear Horizontal Telescopic and Standard Horizontal Flue. This enables the flue products to exhaust further away from the boiler, thereby reducing the impact of pluming. The flue air inlet can be sited closer to doors, opening windows and air bricks, see diagram 9.26.

The maximum length of the Plume Management Kit must NOT exceed 6m with a horizontal concentric flue length of 2m max.

For each 90° bend or 2 x 45° bends the maximum length of the Plume Management Kit must be reduced by 1m.

For more information contact Glow-worm, refer to page 2.

The Plume Management Kit is supplied with installation instructions.

10 Electrical Connection

WARNING: This appliance must be earthed.

This appliance must be wired in accordance with these instructions. Any fault arising from incorrect wiring cannot be put right under the terms of the Glow-worm guarantee. All system components must be of an approved type. Electrical components have been tested to meet the equivalent requirements of the BEAB.

Do not interrupt the mains supply with a time switch or programmer.

Connection of the whole electrical system and any heating system controls to the electrical supply must be through a common isolator.

Isolation should preferably be by a double pole switched fused spur box having a minimum contact separation of 3mm on each pole. The fused spur box should be readily accessible and preferably adjacent to the boiler. It should be identified as to its use.

10.1 Installer Interface

Gain access to the Installer Interface by removing the securing screw, see diagram 10.1.

Remove the cable securing clip which will release the Installer Interface cap, see diagram 10.1.

Release the cable gland, route the mains and system cables through the strain relief and connect to the relevant plug dependant upon your choice of system controls, see diagram 10.2.

10.2 Electrical Connections - Testing

Carry out preliminary electrical system checks as below:

1. Test insulation resistance to earth of mains cables.
2. Test the earth continuity and short circuit of cables.
3. Test the polarity of the mains.

IMPORTANT NOTE

ALL electrical connections to the boiler must be permanently fixed to a wall or a sturdy support feature in a tidy manner.

10 Electrical Connection

REMOVAL AND REPLACEMENT OF INSTALLER INTERFACE AND CAP

13138

VIEW ON UNDERSIDE OF BOILER

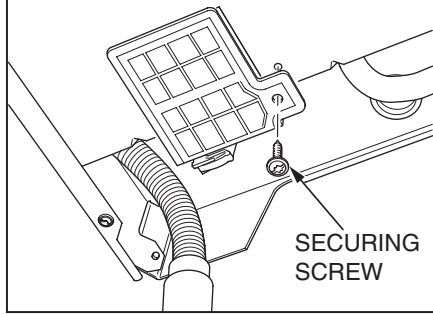

SECURING SCREW

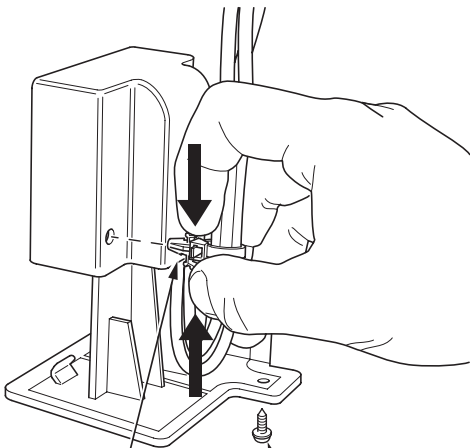

CABLE SECURING CLIP

SECURING SCREW

Diagram 10.1

FLEXICOM OPEN VENT

12613

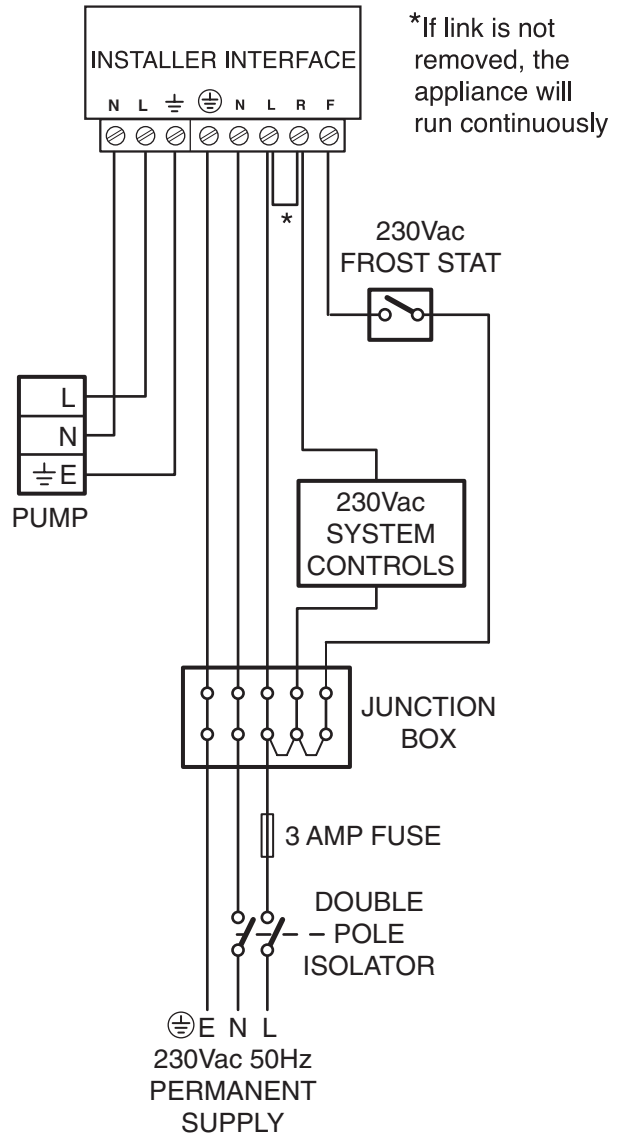

NOTE: ALL CABLES CONNECTED TO THE APPLIANCE SHOULD BE PERMANENTLY FIXED TO THE WALL

Diagram 10.3

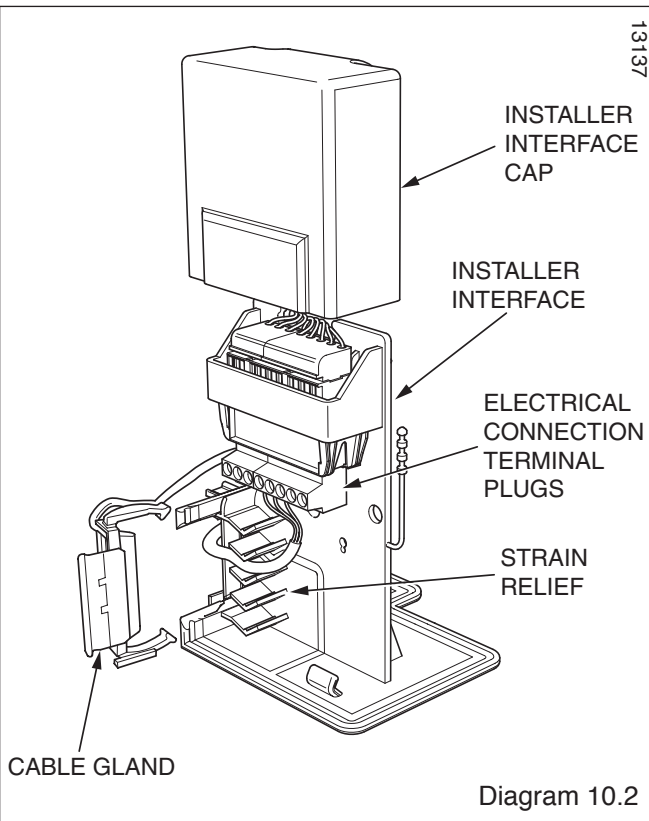

13137

INSTALLER INTERFACE CAP

INSTALLER INTERFACE

ELECTRICAL CONNECTION TERMINAL PLUGS

STRAIN RELIEF

CABLE GLAND

Diagram 10.2

11 Commissioning

11.1 Preliminaries - All Systems

A **competent person** in accordance with the current issue of BS6798 should carry out commissioning.

Make sure that the system has been thoroughly flushed out with cold water.

Refill the system with water, making sure that all the air is properly vented from the system.

Before operating the boiler check that all external controls are calling for heat.

11.2 Sealed Systems

Fill the system until the pressure gauge registers the recommended pressure. Clear any air locks and check for leaks.

Release the cold water to the initial design pressure.

11.3 Preparation for Lighting

Isolate the boiler from the mains electrical supply.

Test for gas soundness and purge air from the gas supply.

Refer to diagram 7.1, turn on the gas service cock slot in line with the length of the valve.

11.4 Initial Lighting

The lighting procedure of the boiler is fully automated.

Check that all external controls are calling for heat.

11.5 Testing - Natural Gas ONLY

Should any doubt exist about the gas rate, check it using the gas meter test dial and stop watch at least 10 minutes after the burner has lit, making sure that all other gas burning appliances and pilot lights are off.

The approximate gas rates:

12hx	: 1.28m ³ /h (45ft ³ /h)
15hx	: 1.60m ³ /h (56.5ft ³ /h)
18hx	: 1.93m ³ /h (68ft ³ /h)
24hx	: 2.58m ³ /h (91ft ³ /h)

The gas valve is factory set for natural gas (G20) and should need no adjustment. It should be checked that the supply pressure is 20mbar when the boiler is firing at full rate.

11.6 Testing - Heating System

Check that all external controls are calling for heat. The boiler will fire automatically. Fully open all radiator valves, flow control valve and bypass valve if fitted.

Balance the radiators as required and if fitted adjust flow control valve to give the required system differential. Turn off all radiators that can be shut off by the user and check to see if less than the maximum differential allowed of 20°C can be achieved across flow and return.

Allow the system to reach maximum temperature then switch off the boiler by isolating from the electrical supply.

Drain the entire system rapidly whilst hot, using the drain tap at the lowest part of the system. Fill and vent the system as described previously in section 11.2

Lock or remove the handles from controls valve and bypass valve to prevent unauthorised adjustment.

11.7 Completion

Adjust the boiler temperature control and any system controls to their required settings. In addition it is necessary to complete the "Benchmark" logbook.

For IE, it is necessary to complete a "Declaration of Conformity" to indicate compliance to I.S.813. An example of this is given in the current edition of I.S.813.

Testing Flue Gases: If any doubt exists that the flue products are not exhausting correctly, investigate by use of a gas analyser (FGA).

11.8 Instruct the User

Instruct and demonstrate the lighting procedure and advise the user on the safe and efficient operation of the boiler.

Instruct on and demonstrate the operation of any heating system controls.

Advise the user on the use and maintenance of any scale reducer and pass on any relevant instructional documents.

Advise that to ensure the continued efficient and safe operation of the boiler it is recommended that it is checked and serviced at regular intervals. The frequency of servicing will depend upon the installation conditions and usage, but in general, once a year should be enough.

Draw attention, if applicable, to the current issue of the Gas Safety (Installation and Use) Regulations, Section 35, which imposes a duty of care on all persons who let out any property containing a gas appliance in the UK.

The user shall not interfere with or adjust sealed components. It is the Law that any servicing is carried out by a **competent person**.

Advise the user that, like all condensing boilers this appliance will produce a plume of condensation from the flue terminal in cool weather. This is due to the high efficiency and hence low flue gas temperature of the boiler.

Advise the user of the precautions necessary to prevent damage to the system, boiler and the building, in the event of the heating system being out of use during frost or freezing conditions.

Advise the user that the permanent mains electrical supply SHOULD NOT be switched off, as the built in frost protection and pump/valve saver program would not be operable.

Reminder, leave these instructions and the 'Benchmark' logbook with the user.

12 Servicing

Important Notes

To ensure the continued efficient and safe operation of the boiler it is recommended that it is checked and serviced at regular intervals. The frequency of servicing will depend upon the particular installation and usage, but in general once a year should be enough.

It is the Law that any servicing is carried out by a **competent person**.

When replacing a part on this appliance, use only spare parts that you can be assured conform to the safety and performance specification that we require. Do not use reconditioned or copy parts that have not been clearly authorised by Glow-worm.

Testing Flue Gases: If any doubt exists that the flue products are not exhausting correctly, investigate by use of a gas analyser (FGA). Measurement of the products of combustion can be achieved by connection of a probe to the combustion analyser test point on the flue elbow, refer Combustion Check.

IMPORTANT NOTE: Products of combustion will be discharged when the cap is removed. It is important to replace the cap immediately.

Before commencing with a service or replacement of parts the boiler should be isolated from the electrical supply and the gas supply should be turned off at the gas service cock, see diagram 12.1.

Combustion Check

A combustion check should not be necessary unless a gas carrying component has been replaced or the combustion setting is suspect.

Connect a CO₂ combustion analyser to the test point, see diagram 12.2.

Turn on the gas service cock, see diagram 12.1.

Turn on the electrical supply, the appliance will begin the ignition sequence.

A competent person should only carry out any adjustment to the gas valve, refer to diagram 12.3.

Monitor the combustion reading and at max rate the reading should be 9.3% ± 0.5.

If adjustment proves necessary then proceed as follows:

Press the “reset” button on the controls fascia, release and immediately press and hold in the “+” button. After approximately 5 seconds “Hi” will be displayed. Pressing the mode button when “Hi” is selected will force the boiler to maximum rate, the display will flash between “Hi” and the “default display” this will indicate the boiler has been forced to maximum.

Adjust the maximum rate CO₂ with the throttle to 9.3%. (Rotate anti-clockwise to increase).

To exit the check sequences press the “mode” and “+” buttons simultaneously, this will reset the boiler to the default display.

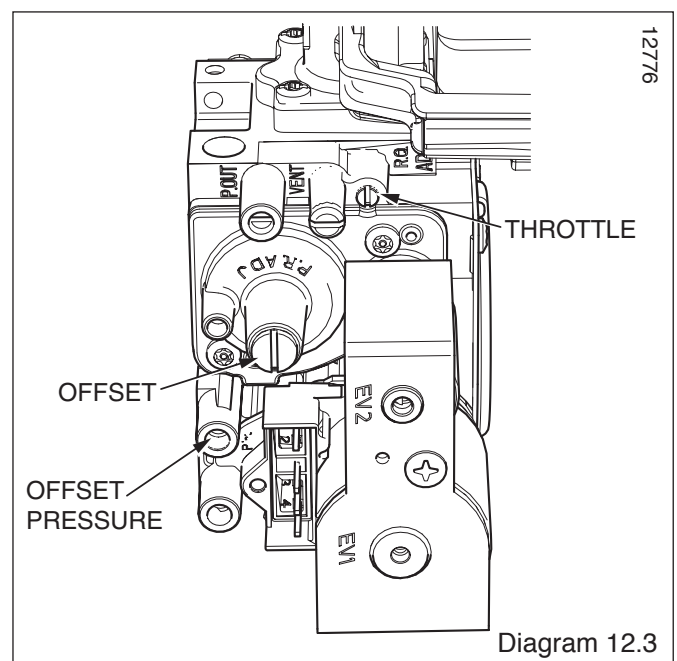
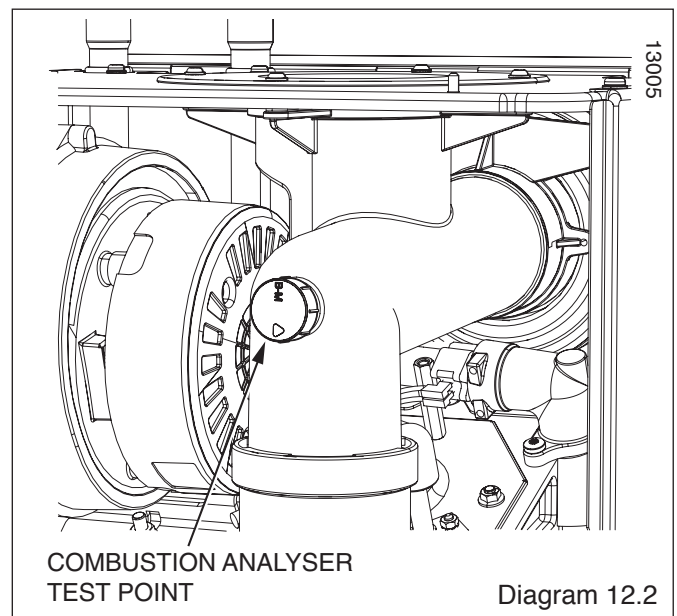
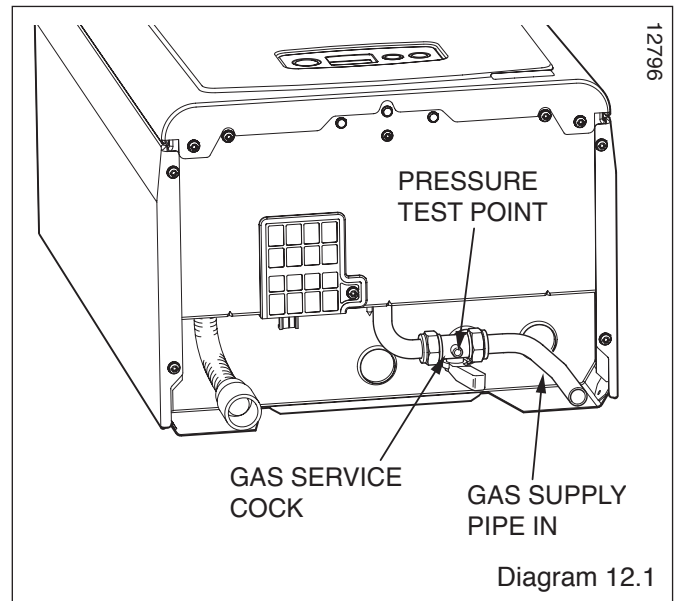

12 Servicing

Monitor the combustion reading and at min rate the reading should be $9.3\% \pm 0.5$.

If adjustment proves necessary then proceed as follows:

Press the "reset" button on the controls fascia, release and immediately press and hold in the "+" button. After approximately 5 seconds "Hi" will be displayed. Pressing the "+" or "-" buttons will cycle between "Hi" and "Lo". Pressing the mode button when "Lo" is selected will force the boiler to minimum rate, the display will flash between "Lo" and the "default display" this will indicate the boiler has been forced to minimum.

Refer to diagram 12.3, remove the offset screw cover.

Adjustment of the CO_2 at minimum rate is very coarse so carefully adjust the CO_2 with the offset adjustment to 9.3%. (Rotate clockwise to increase).

Refit the offset cover and the cap on the test point.

To exit the check sequences press the "mode" and "+" buttons simultaneously, this will reset the boiler to the default display.

12.1 General

Removal of the front panel is required for all routine servicing. Remove the two screws on the underside of the front panel, see diagram 12.4 and lift off the retaining pins.

For access inside the appliance a Torx T20 drive is required or alternatively a flat blade screwdriver can be used.

Unless stated otherwise any part removed during servicing should be replaced in the reverse order to removal.

Servicing should always include the removal of any debris from the condensate pipe and siphon.

After completing any servicing of gas carrying components, ALWAYS test for gas soundness and carry out a functional test of the controls.

12.2 Flue Hood

Ease the securing clips away from the flue hood sump and push flue hood up slightly towards flue hood top, see diagram 12.5.

To remove swivel flue hood 90° and pull down and out towards front of boiler.

Check seal for wear or damage and replace if necessary.

IMPORTANT: Do not allow fixings, nuts, screws, etc. to fall into the open flue hood sump, use a temporary cover whilst removing any parts.

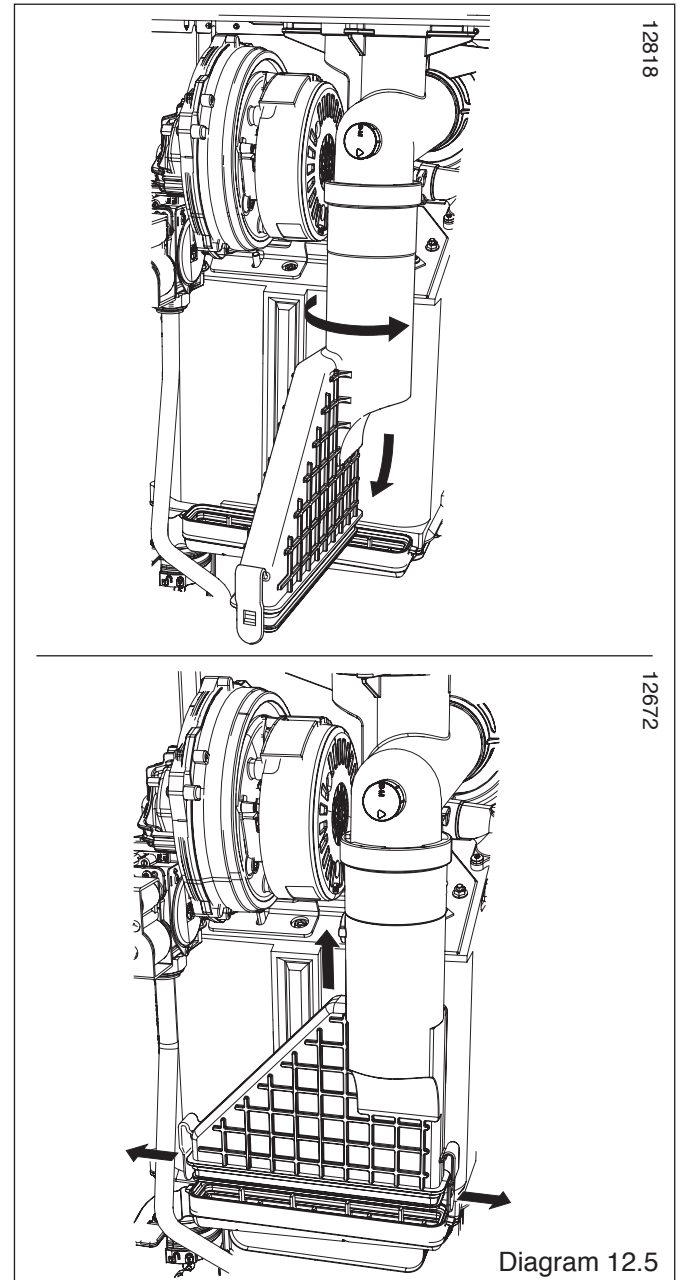
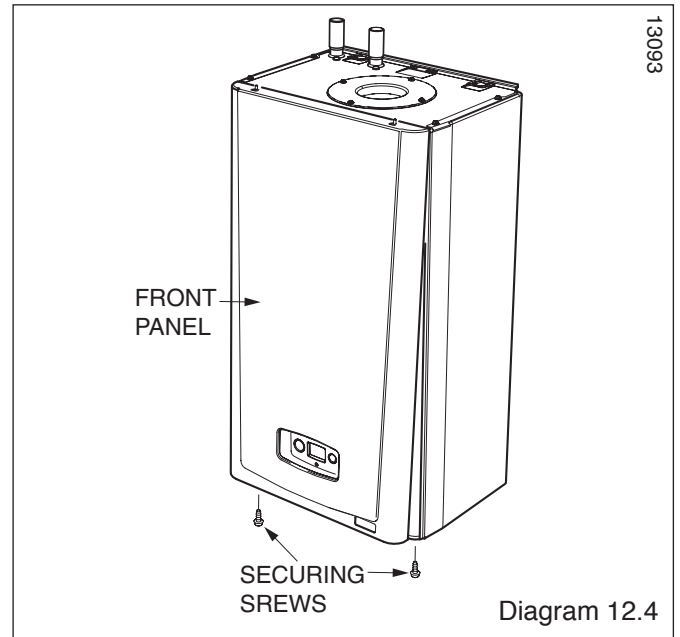

12 Servicing

12.3 Burner

Disconnect the gas supply at the gas valve and electrical connections, see diagram 12.6.

The Silencer (front) is a push fit, so there is no need for tools to remove or fit, see diagram 12.7.

Release the igniter unit support bracket, see diagram 12.8.

Remove the fan retaining bracket.
To ease removal of the securing nut from the fan retaining bracket, a flat bladed screwdriver can be used in the position shown and gently levered down as indicated, see diagram 12.9.

Remove the fan and gas valve assembly.

The silencer (rear) is a push fit so no tools are required for its removal or fitting, see diagram 12.10.

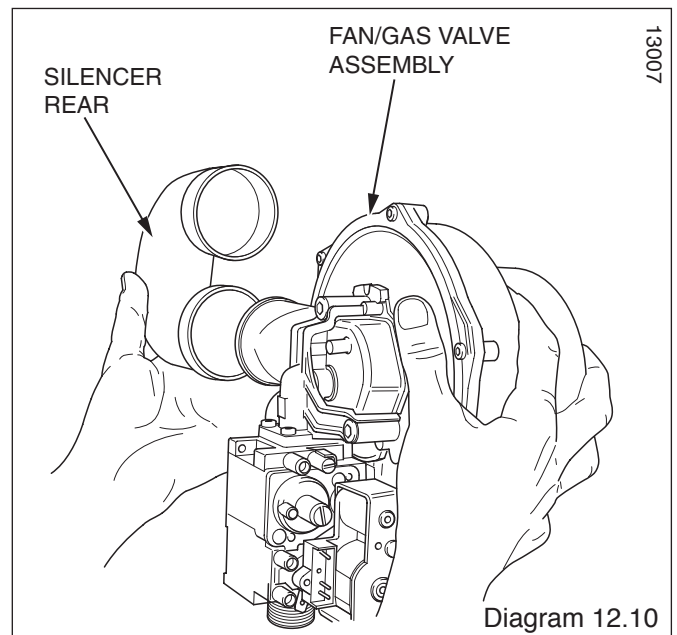
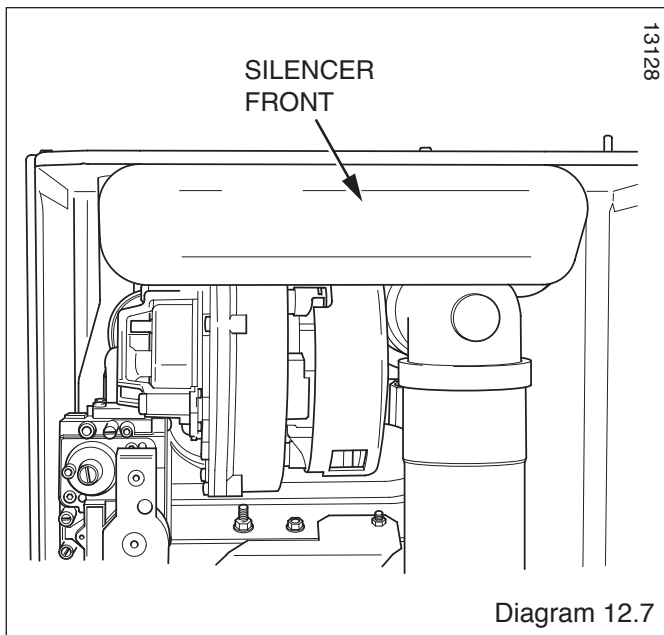
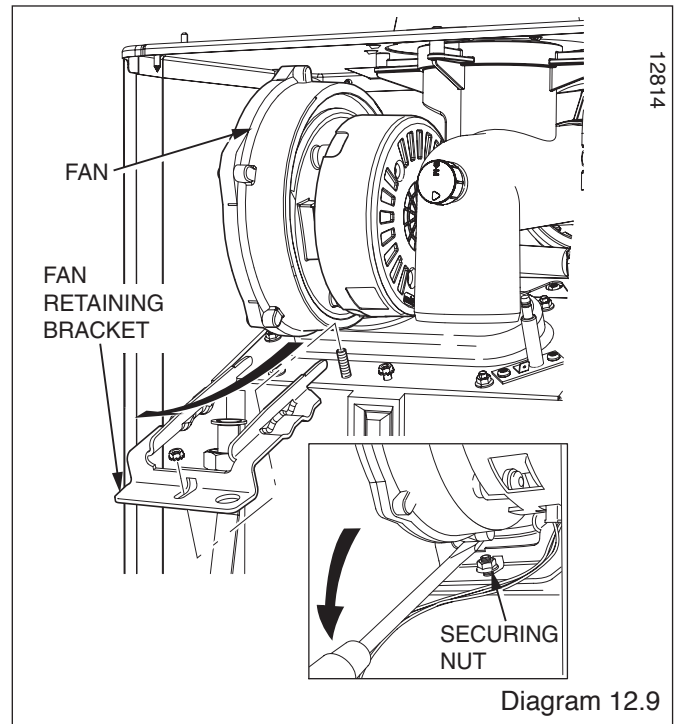
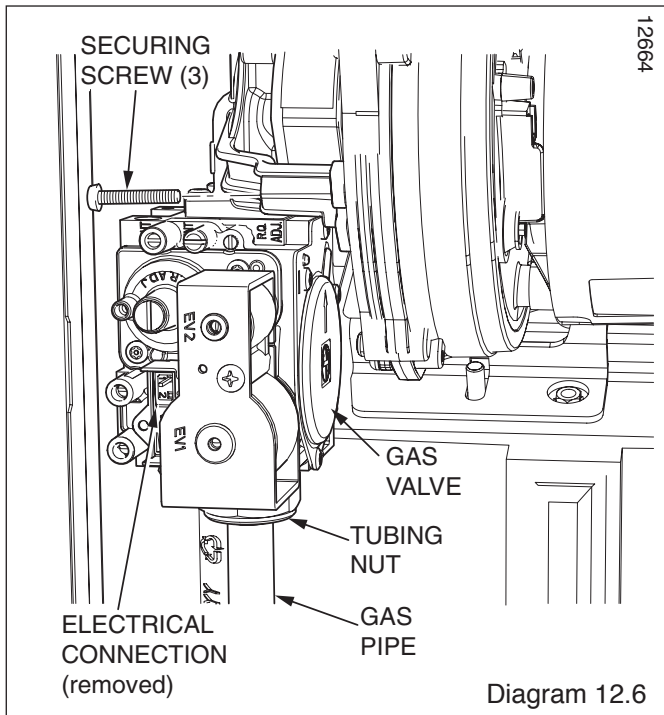
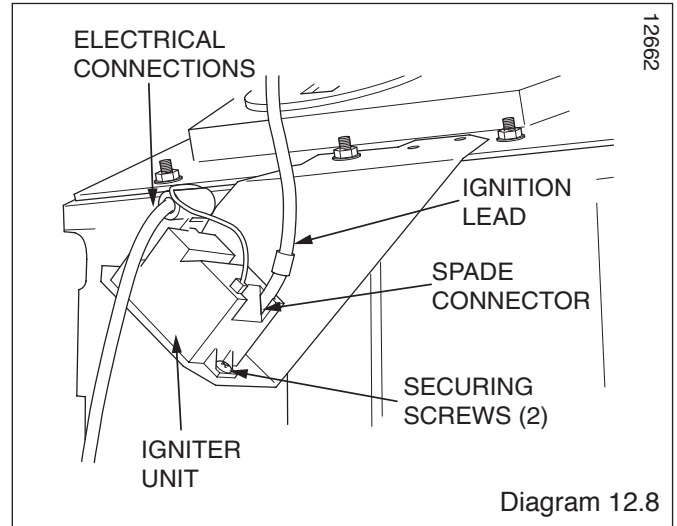

12 Servicing

Check the spark electrode gap is 4mm. Clean and adjust as necessary, diagram 12.11.
It should not be necessary to remove the spark electrode from the burner during servicing.

Remove the flanged nuts and studs that secure the burner, note that two studs at the rear also hold the fan clamping bracket, see diagram 12.12.

Clean the burner with a soft brush taking great care not to damage the surface of the burner. DO NOT use wire or sharp instruments to clean the mesh of the burner.

NOTE: The burner gasket should be inspected but will not need replacing unless there are signs of wear or damage.

Follow the tightening sequence when re-fitting the burner, see diagram 12.12.

12.4. Heat Exchanger

Remove loose debris from inside the heat exchanger using a soft brush and vacuum cleaner.

Carefully flush by spraying water into the heat exchanger, any remaining debris should pass through the condensate trap (Ensure the water is kept away from electrical components).

12.5 Condensate Trap

The condensate trap does not normally need removing during servicing unless the service fill level is at full, see diagram 12.13 and section 14.11 for removal.

To flush the condensate drain carefully pour water into the heat exchanger and check that water flows freely to drain.

12.6 Casing panel seal check

Check the condition of the seal and replace if worn or damaged.

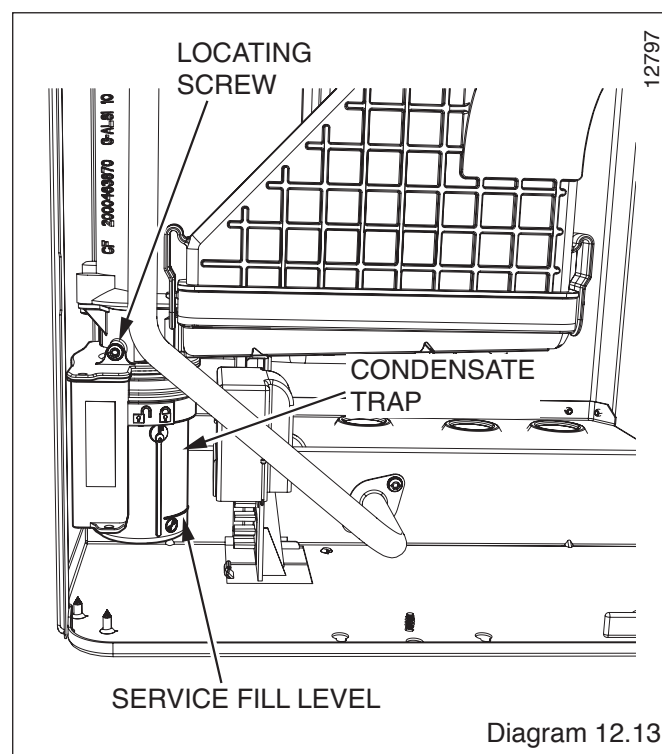
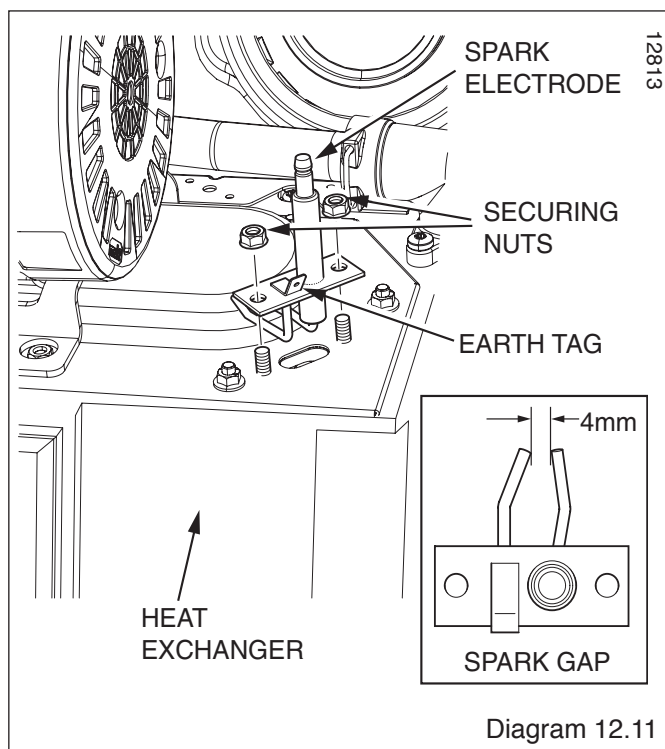
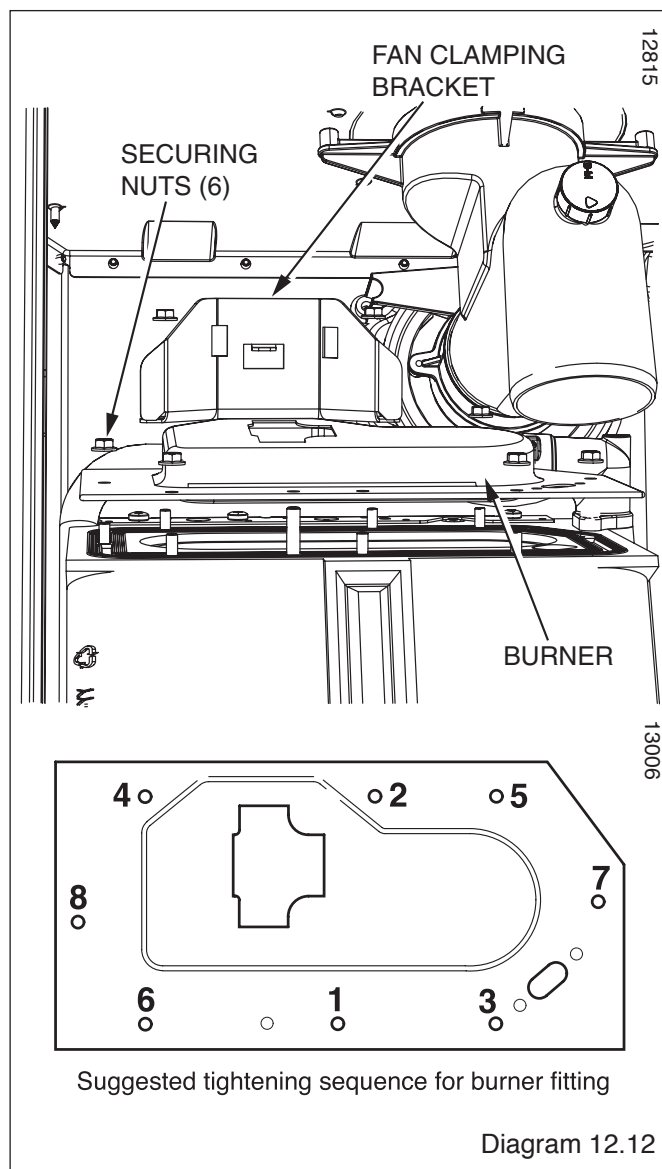

13 Fault Finding

NOTE

Before trying to operate the boiler make sure that :

- All gas supply cocks are open and that the gas supply has been purged of air.
- There is a permanent mains supply to the boiler.
- There is a heating demand from the external controls.

WARNING

Always isolate the boiler from the electrical supply before carrying out any electrical replacement work.

Always check for gas soundness after any service work.

Electrical Testing

Should there be any doubt about the voltage supply to any of the components, it is possible to carry out a simple electrical test.

Important: On completion of the Service/Fault Finding tasks which have required the breaking and remaking of the electrical connections the earth continuity, polarity, short circuit and resistance to earth checks must be repeated using a suitable multimeter.

To carry out the electrical test, gain access, as follows:
Hinge down the control box and unclip the rear cover to gain access. Refer to the wiring diagram 13.1 and fault finding charts, diagrams 13.2 to 13.6.

13 Fault Finding

12861

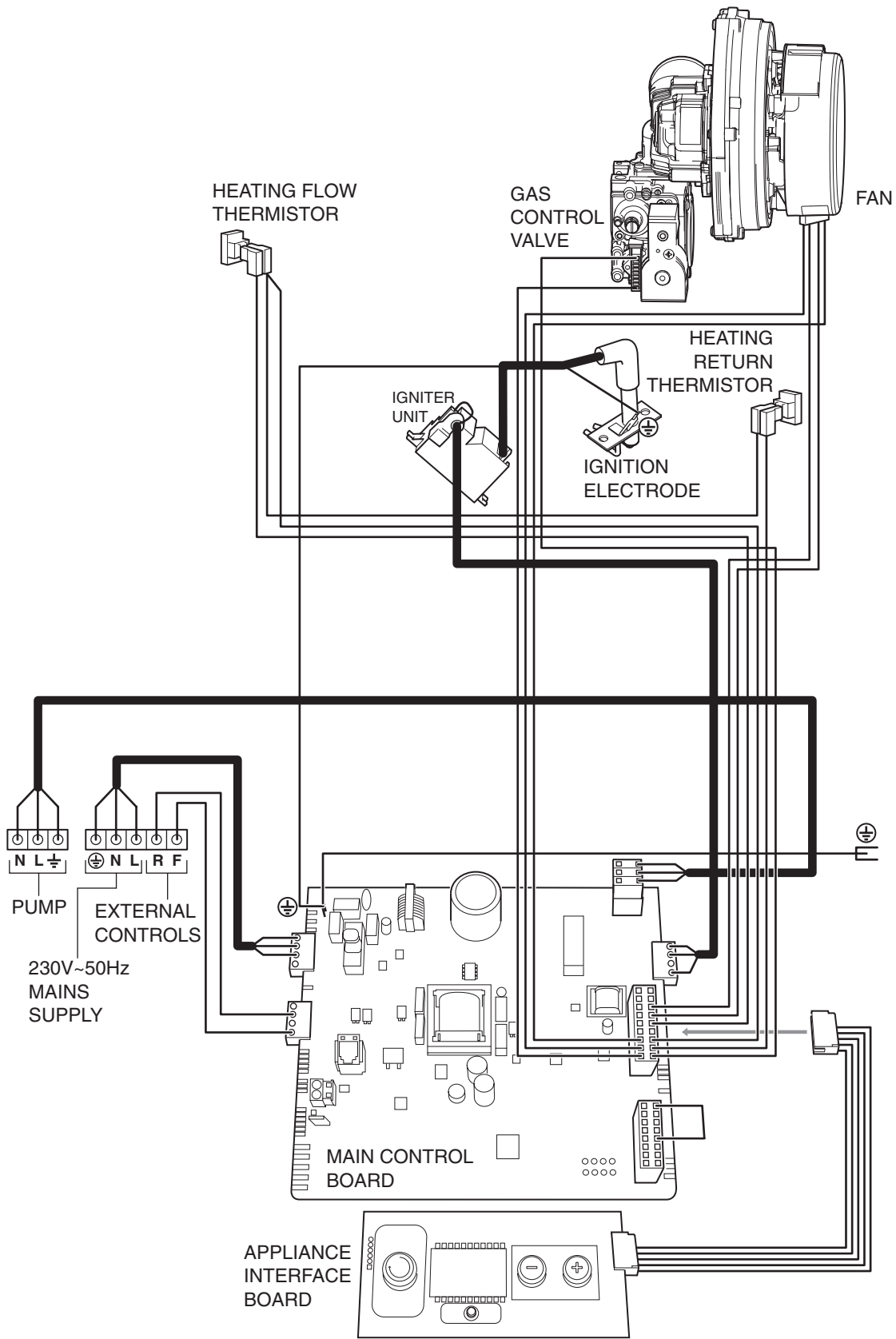

FLEXICOM HX

Diagram 13.1

13 Fault Finding

13012

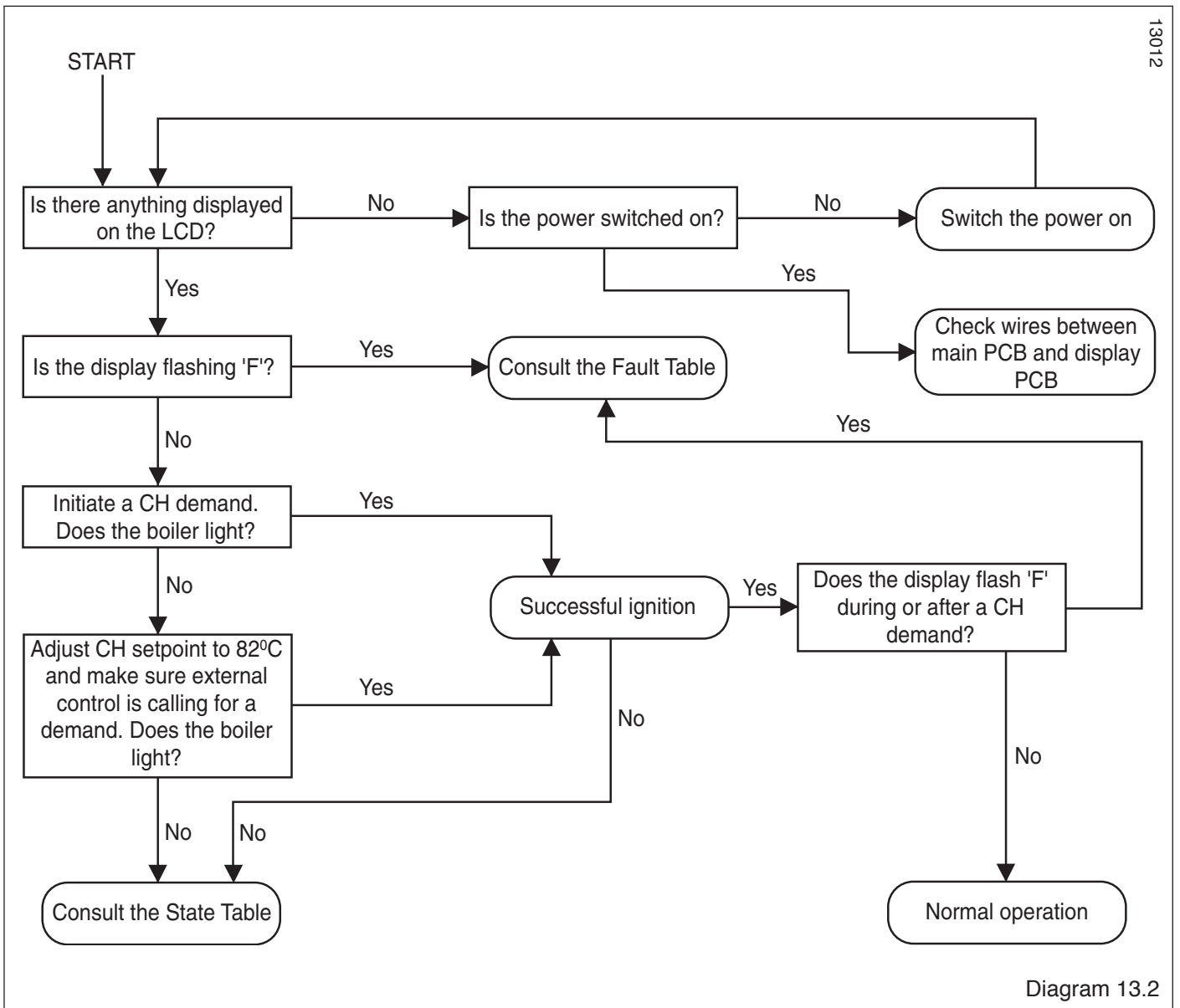

Diagram 13.2

13 Fault Finding

In all circumstances press the reset button to clear the fault. If the fault persists, consult the table below.

FAULT LISTS

CODE	DESCRIPTION	POSSIBLE CAUSE
F1	Boiler has attempted to light 5 times and failed on all occasions	Gas tap is closed. Gas valve connector is loose, unconnected, faulty, or wires are trapped. Ignitor connectors are loose, unconnected, faulty, trapped. Faulty Ignitor. Low gas inlet pressure. Incorrect gas valve adjustment. Electrode Ignition leads loose, unconnected, faulty, trapped. Electrode broken, defective, or position incorrect. Air inlet blocked, flue inlet blocked, flue duct leaking. Earthing connection loose, disconnected.
F4	Flame goes out whilst lit during a demand	Gas tap is closed. Gas valve connector is loose, unconnected, faulty, or wires are trapped. Ignitor connectors are loose, unconnected, faulty, trapped. Faulty Ignitor. Low gas inlet pressure. Incorrect gas valve adjustment. Electrode Ignition leads loose, unconnected, faulty, trapped. Electrode broken, defective, or position incorrect. Air inlet blocked, flue inlet blocked, flue duct leaking. Earthing connection loose, disconnected.
F6	Central Heating Flow Thermistor connection fault	Thermistor wires unconnected, faulty, trapped.
F10	Central Heating Return Thermistor connection fault	Thermistor wires unconnected, faulty, trapped.
F13	PCB Memory or sensing fault	Loose connections on Main PCB or display PCB. Central Heating Flow or Return Thermistor wires unconnected, faulty, trapped. Electrode Ignition leads loose, unconnected, faulty, trapped. Earthing connection loose, disconnected.
F22	Low Water pressure or Ignition temperature rise too slow	Not enough water in the system. Central Heating Flow or Return Thermistor wires loose, faulty, trapped. Central Heating Flow or Return Thermistor not connected to pipe correctly Air in the system. Faulty pump or pump speed too fast.
F25	Central Heating Flow temperature rise too high during operation. Central Heating Return temperature rise or temperature difference too high during operation. Central Heating Temperature difference (between Flow and Return) too high during operation.	Check thermistors are connected to pipes correctly. Air in the system. System is too restrictive.
F43	Generic error	Check all electrical connections - internal & external
F70	Software incompatible	Telephone Group Service
NO DISPLAY - Check connection from display PCB to main PCB connector X51		Diagram 13.3

13130

13 Fault Finding

State list - To access the state lists the '-' button must be pressed for longer than 5 seconds until it begins to flash 'S' and then a number to indicate the state. The state numbers are given below.

STATE LISTS

13131

	Central heating mode	Possible Causes
S.00	no heating required	
S.01	fan pre-run	
S.02	pump pre-run	
S.03	ignition	
S.04	burner on	
S.05	pump / fan overrun	
S.06	fan overrun	
S.07	pump overrun	
S.08	Anti cycling period	

Diagram 13.4

13 Fault Finding

To enter the diagnostics menu follow the procedure below:-

Press and hold the ‘↶’ and ‘+’ buttons for approx 5 seconds until the screen changes. Use the ‘+’ or ‘-’ button to select the number 96, this is the password. Hold the ‘↶’ for approx 5 seconds when 96 is selected, when the screen changes release the button. The screen will flash between ‘L1’ and a number. ‘L1’ indicates you have level 1 access, the number indicates the diagnostic number below. Use the ‘+’ and ‘-’ to cycle through the selections below. To select a diagnostic number press the ‘↶’ button when the correct number is selected. The display will show the parameter value of the diagnostic number selected. To return to the diagnostic number selector simply press the ‘↶’ button. To change the parameter use the + or - buttons. Once the value has been changed it must be saved by holding the ‘↶’ button for approximately 5 seconds. This will return to the diagnostic number selector.

DIAGNOSTIC CODES - LEVEL 1

Installer Access

Display	Meaning	
d.00	Heating part load	Adjustable heating part load in kW (factory setting: max. output)
d.01	Water pump over run time for heating mode	2 - 60 min (factory setting: 5 min)
d.02	Max. burner anti cycling period at 20°C Flow temperature	3 - 60 min (factory setting: 20 min)
d.04	N/A	N/A
d.05	Flow temperature setpoint	In °C, min. 38 and max. 82
d.07	N/A	N/A
d.08	External controls heat demand (Clamp 3-4)	0= no heat request (open) 1 = heat request (closed)
d.09	Flow target temperature from external analogue regulator to terminal 7 R	In °C, minimum from ext. eBUS target value and target value terminal 7
d.10	Status internal heating pump	1,2 = on, 0 = off
d.11	Status external heating pump	1 to 100 = on, 0 = off
d.13	Hot water circulation pump (via accessory module)	1 to 100 = on, 0 = off
d.23	Summer/Winter function	1 = Winter, 0 = Summer
d.25	Hot water activation via eBUS Control	1 = yes, 0 = no
d.33	Fan speed target value	in rpm/100
d.34	Fan speed actual value	in rpm/100
d.40	Flow temperature	Actual value in °C
d.41	Return temperature	Actual value in °C
d.44	Ionisation current	Actual value (10nA)
d.47	N/A	N/A
d.60	Number of safety temperature limiter cut offs	Quantity
d.61	Number of lock outs	Number of unsuccessful ignitions in the last attempt
d.64	Average ignition time	In seconds
d.65	Maximum ignition time	In seconds
d.68	Unsuccessful ignitions in the first attempt	Quantity
d.67	Remaining burner anti cycling time (block time)	Quantity
d.69	Unsuccessful ignitions in the second attempt	Quantity
d.76	Appliance variant (device specific number)	00 to 99
d.80	Heating operating hours	in h
d.82	Cycles in heating mode	Quantity
d.84	Maintenance indicator: Number of hours until next maintenance	Quantity
d.90	Digital regulator status	1 = identified, 0 = unidentified (eBUS Address <= 10)

13075

Diagram 13.5

14 Replacement of Parts

14.1 General

Replacement of parts must be carried out by a **competent person**.

Before replacing any parts the boiler should be isolated from the mains electric supply and the gas should be turned off at the service cock on the boiler, see diagram 14.1.

Ensure that components with electrical connections are disconnected before removal.

Unless stated otherwise parts are replaced in the reverse order to removal.

After replacing any parts always test for gas soundness and if necessary carry out functional test of the controls.

For replacement of parts the front casing of the boiler will need to be removed. To remove undo the two screws on the underside of the front casing and lift off.

14.2 Igniter Unit

For access, refer to section 14.1.

Remove ignition lead and electrical connections then remove igniter unit by removing two securing screws, see diagram 12.8.

14.3 Ignition Lead

For access, refer to section 14.1.

Pull the spark plug style connector off the spark electrode and the spade connector connected to the igniter unit, see diagram 12.8.

14.4 Silencer Assembly (front)

For access, refer to section 14.1.

Pull forwards to remove.

The silencer is a push fit so no tools or fixings are required for its removal or fitting, see diagram 12.7.

14.5 Gas Valve

Remove the three securing screws, holding the gas valve to the fan, see diagram 12.6.

Remove the gas valve.

After re-fitting check the combustion CO_2 and adjust if necessary, refer to section 12, Combustion Check.

After assembly test for gas soundness and purge in accordance with the current issue of BS6891 or in IE, the current edition of I.S.813 "Domestic Gas Installations".

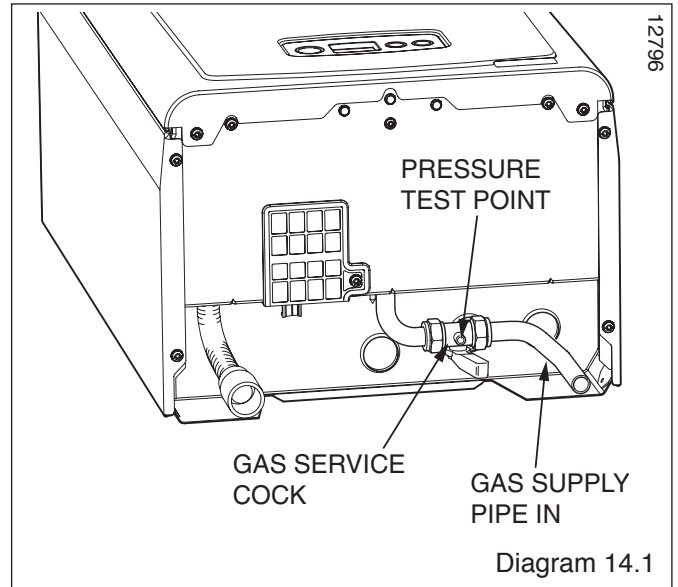

14 Replacement of Parts

14.6 Flue Hood

For access, refer to section 14.1.

Pull the flue hood securing clips away from the flue hood sump and push flue hood up slightly towards flue hood top, see diagram 12.5.

To remove swivel flue hood 90° and pull down and out towards front of boiler.

14.7 Fan/Gas valve assembly

For access, refer to section 14.1.

Undo the tubing nut to remove the gas valve from the gas pipe and any electrical connections, see diagram 12.6.

Remove the securing nut holding the fan retaining bracket, press down on burner to ease removal of securing nut. Slide out the fan retaining bracket.

Lift front of bracket away from stud and pull forward to release the fan, see diagram 12.9.

Lift fan/gas valve assembly up and forward away from locating studs.

Remove fan gasket and replace.

To replace the fan and retaining bracket correctly, insert into slots on fan clamping bracket and locate onto lugs on the burner, see diagram 12.2.

14.8 Silencer assembly (rear)

For access, refer to section 14.1.

Remove the fan/gas valve assembly, see section 14.7.

Pull Silencer rear away from fan/gas valve assembly.

The rear silencer is a push fit so no tools or fixings are required for its removal or fitting, see diagram 12.10.

14.9 Spark Electrode

For access, refer to section 14.1.

Remove the spark plug lead and earth lead.

Remove the two securing nuts.

Withdraw the spark electrode by slowly pulling up and leaning it forward towards the centre of the heat exchanger to ensure that the electrode does not foul on the hole in the burner casing.

Check spark gap, see diagram 12.11.

14.10 Burner

For access, refer to section 14.1.

Remove igniter unit, flue hood, fan and gas valve assembly and spark electrode lead, refer to relevant sections.

Remove the flanged nuts and studs that secure the burner, note that two studs at the rear also hold the fan clamping bracket, see diagram 12.12.

NOTE: The burner gasket should be inspected but will not need replacing unless there are signs of wear or damage.

IMPORTANT: Do not allow fixings, nuts, screws, etc. to fall into the open flue hood sump, use a temporary cover whilst removing any parts.

14 Replacement of Parts

14.11 Condensate Trap

For access, refer to section 14.1.

Remove locating screw, see diagram 12.13.

Disconnect the flexible condensate drain pipe from the external plastic drain pipe beneath the boiler.

Carefully pull the condensate trap down and forward so as not to spill its contents. The trap should be removed complete with the sealing grommet and flexible condensate drain pipe.

14.12 Heating Flow Thermistor

For access refer to section 14.1

Remove the silencer front, fan/gas valve assembly and flue hood for access. See relevant sections.

Refer to diagram 14.2.

Remove the electrical connections from the thermistor.

Remove the retaining clip from the flow pipe.

Remove the thermistor from the retaining clip.

Note that the polarity of the wiring to thermistors is unimportant.

14.13 Heating Return Thermistor

For access, refer to section 14.1.

Refer to diagram 14.3.

Remove the electrical connections from the thermistor.

Remove the retaining clip from the return pipe.

Remove the thermistor from the retaining clip.

Note that the polarity of the wiring to thermistor is unimportant.

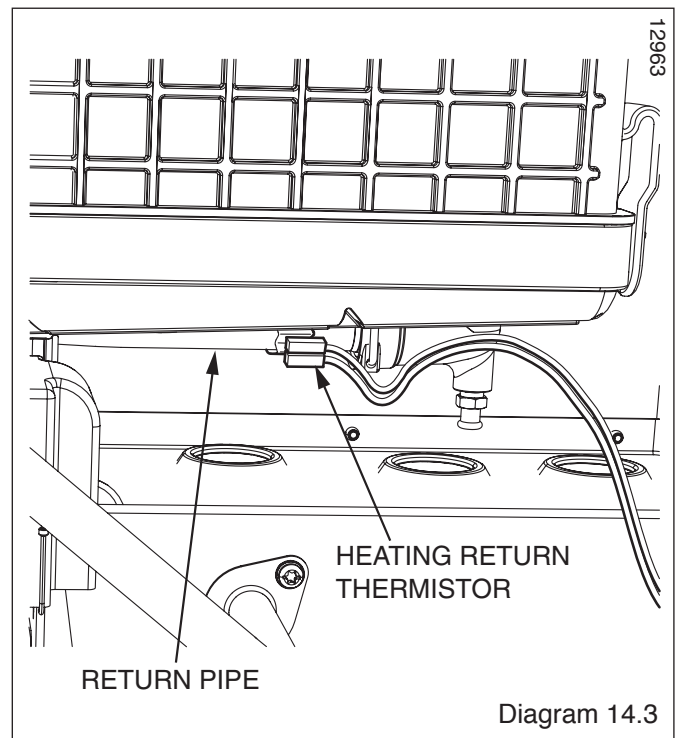
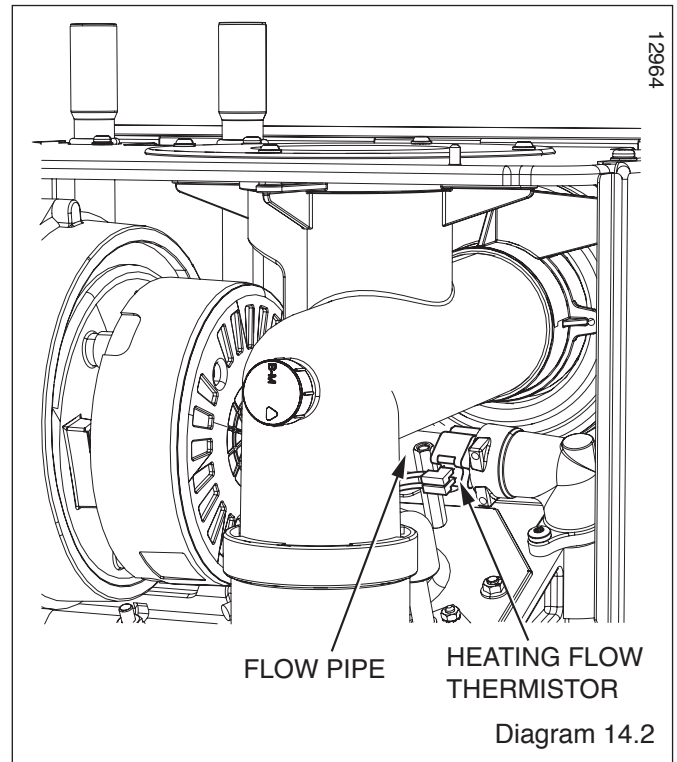

14 Replacement of Parts

14.14 Heat Exchanger

For access, refer to section 14.1.

Remove silencer front, flue hood, gas valve / burner assembly, spark electrode lead, burner and condense trap.

Drain the heat exchanger using the drain point on the right hand side of the heat exchanger, see diagram 14.4.

Undo the screws securing the flanged elbow on the top right hand side of the heat exchanger.

Remove retaining clip from the flanged elbow on the bottom of the heat exchanger.

Remove screws securing the heat exchanger, one on top and one underneath the heat exchanger.

Lift up heat exchanger slightly to disengage it from its hanging bracket.

Remove the heat exchanger by pulling forward, then pulling to the right to disengage the return pipe and tilting backwards to ease removal complete with sump and flanged elbows.

14.15 Casing Seal

Refer to Section 12.7.

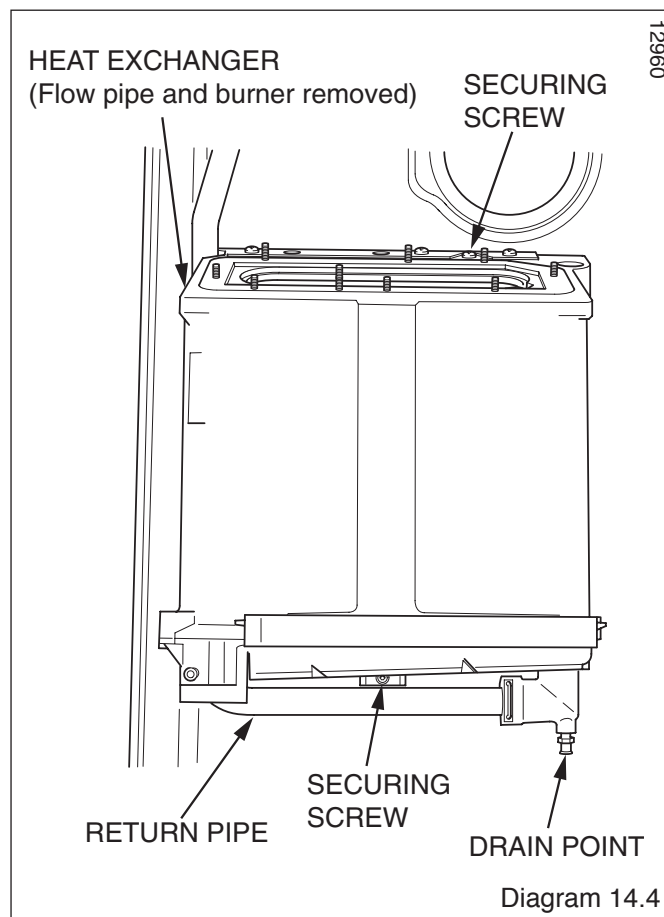

14 Replacement of Parts

14.16 Access to User interface and Main PCB

For access, refer to section 14.1.

Hinge down the control box and unclip the rear cover to gain access.

Remove electrical connections from main PCB noting their positions for replacement.

Unclip main PCB and remove, see diagram 14.5.

Unclip user interface and remove.

For replacement, see diagram 14.6 and ensure that the user interface connection cable is refitted.

NOTE: When re-fitting any of the control boards make sure you support the control box to avoid straining hinges as you push down and clip back into place.

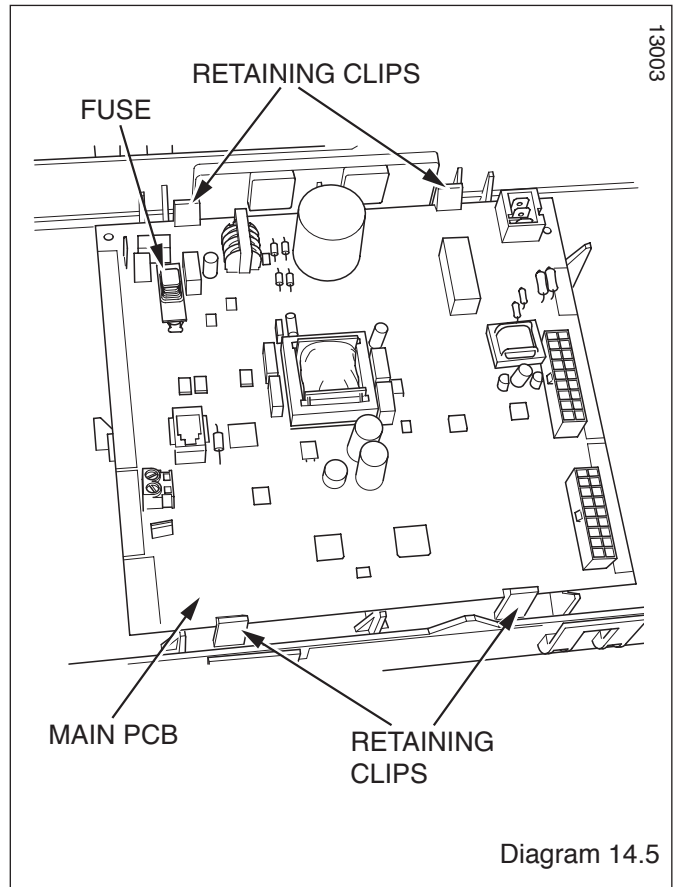

Diagram 14.5

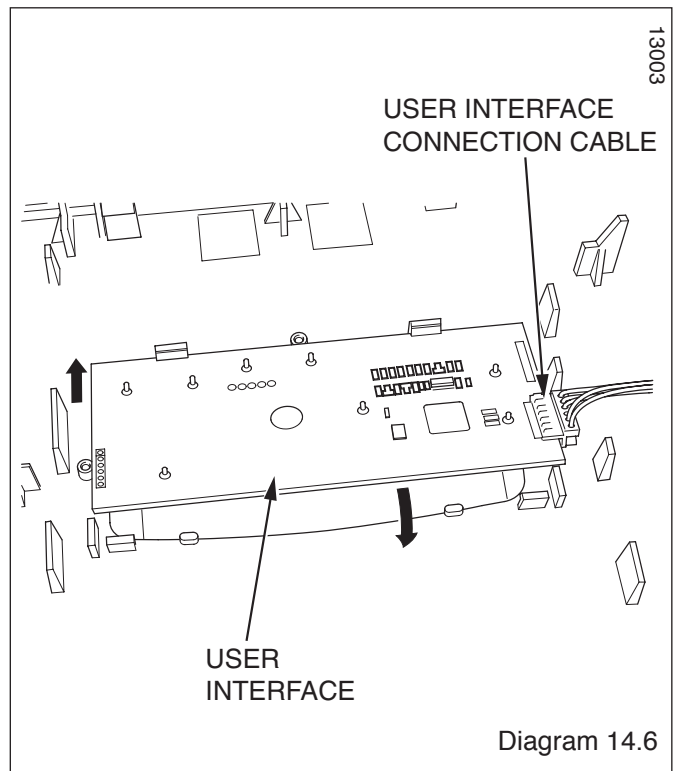

Diagram 14.6

14 Replacement of Parts

14.17 Control Box

For access, refer to section 14.1.

Hinge down the control box and unclip the rear cover to gain access.

Remove relevant electrical connections from main PCB and grommets from the control box.

IMPORTANT: Support the control box whilst undoing the hinges.

Remove the hinge securing screws accessed from beneath the boiler and remove the control box, see diagram 14.7.

14.18 Fuse - Main PCB - Control Box

For access, refer to section 14.16.

The fuse is located at the top left hand corner of the main PCB, see diagram 14.5.

14.19 Installer Interface

Remove the Installer Interface securing screw accessed from beneath the boiler.

Carefully pull down the Installer Interface to remove, see diagrams 10.1 and 10.2.

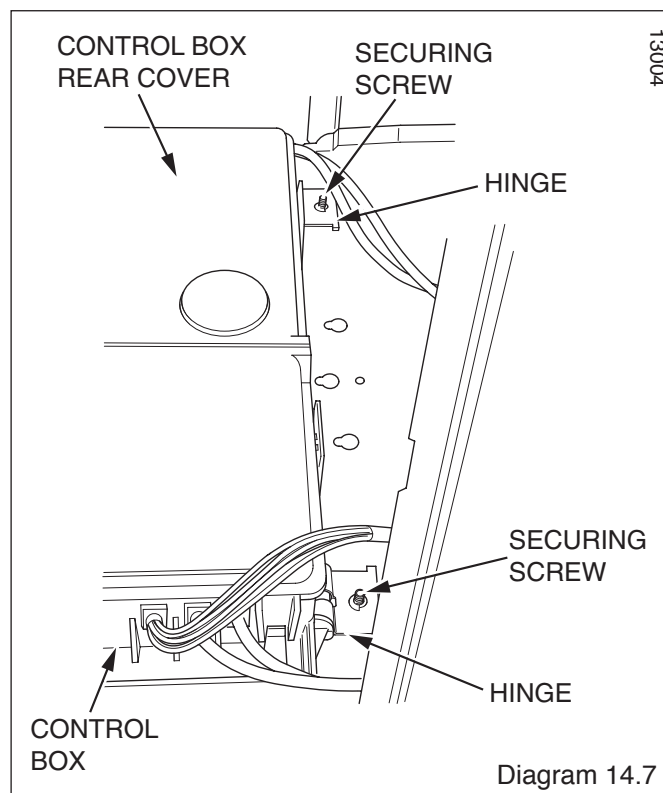

Diagram 14.7

15 Spare Parts

Key No.	Part No.	Description	GC No
1	0020020734	Fan	XXXXXX
2	0020020763	Igniter unit	XXXXXX
3	0020020781	Heating flow & return thermistor (2)	XXXXXX
4	0020020735	Gas valve	XXXXXX
5	0020020731	Spark Electrode	XXXXXX
6	0020020728	Burner	XXXXXX
7	0020023826	User interface	XXXXXX
8	0020023825	Main P.C.B.	XXXXXX

13013

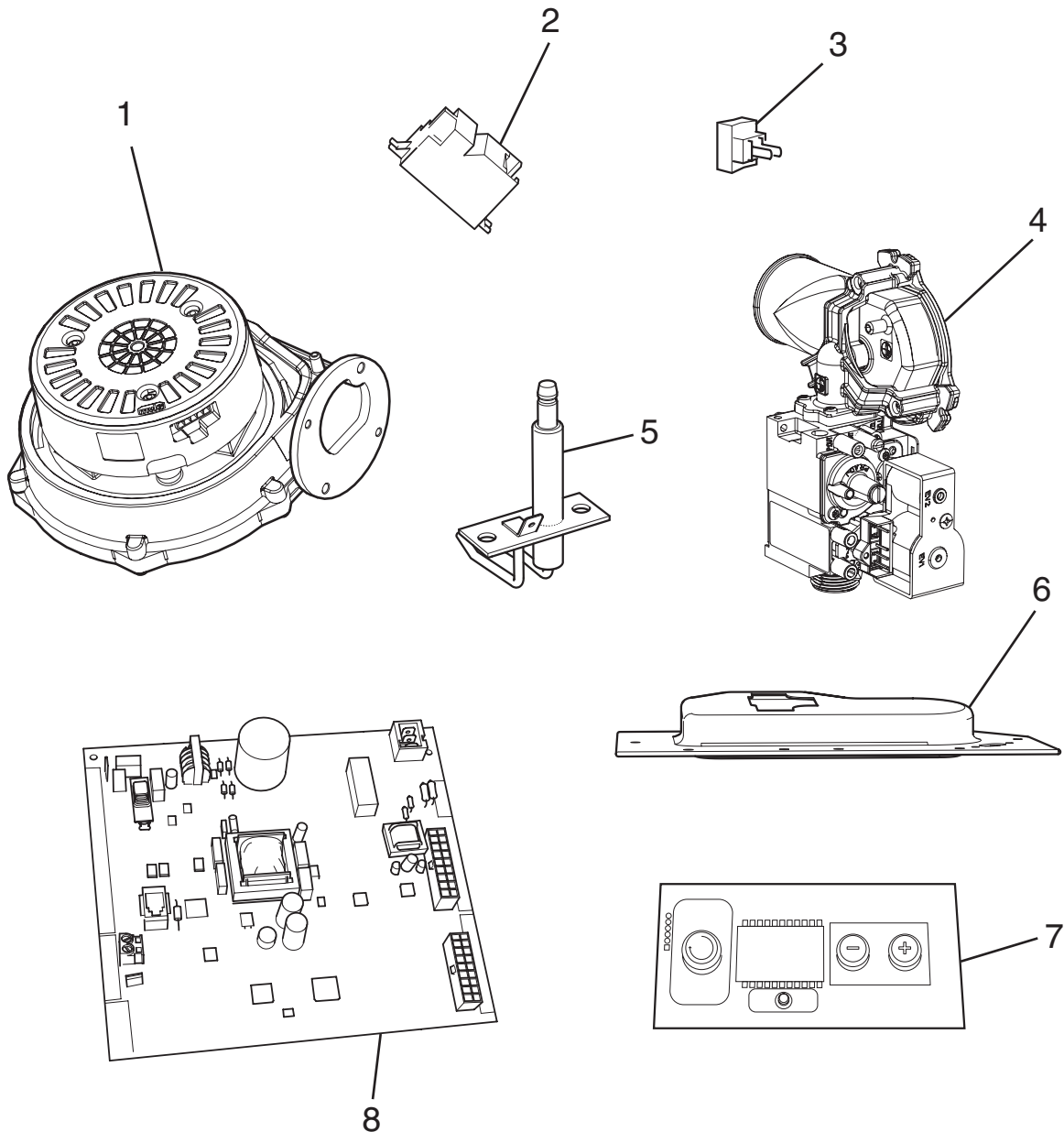

Diagram 15.1

16 Manual Handling

IMPORTANT. With regards to the Manual Handling Operations, 1992 Regulations, the following lift operation exceeds the recommended weight for a one man lift.

General recommendations when handling

Clear the route before attempting the lift.

Ensure safe lifting techniques are used – keep back straight – bend using legs. Keep load as close to body as possible. Do not twist – reposition feet instead. If 2 persons performing lift, ensure co-ordinated movements during lift. Avoid upper body/top heavy bending - do not lean forward/sideways. Recommend wear suitable cut resistant gloves with good grip to protect against sharp edges and ensure good grip. Always use assistance if required.

Removal of carton from delivery van

Recommend 2 person lift or 1 person with use of sack truck. If 1 person is performing lift, straddle the load, tilt and place carton into position on truck. Recommend secure appliance onto truck with suitable straps. Ensure safe lifting techniques are used – keep back straight – bend using legs. Keep load as close to body as possible. If 2 persons performing lift, ensure co-ordinated movements during lift. Always use assistance if required.

Carriage of carton from point of delivery to point of installation – ground floor.

Recommend 2 person lift or 1 person with use of sack truck. If 1 person is performing lift, straddle the load, tilt and place carton into position on truck. Recommend secure appliance onto truck with suitable straps. Ensure safe lifting techniques are used – keep back straight – bend using legs. Keep load as close to body as possible. If 2 persons performing lift, ensure co-ordinated movements during lift. Clear the route before attempting the lift. If removing boiler from truck straddle the load and tilt forwards to facilitate secure grip. Ensure safe lifting techniques are used – keep back straight – bend using legs. Do not twist – reposition feet instead. Take care to avoid trip hazards, slippery or wet surfaces and when climbing steps and stairs. Always use assistance if required.

Carriage of carton from point of delivery to point of installation – first or higher floor, cellar.

Recommend 2-person lift or 1 person with use of sack truck. If 1 person is performing lift, straddle the load, tilt and place carton into position on truck. Recommend secure appliance onto truck with suitable straps. Ensure safe lifting techniques are used – keep back straight – bend using legs. Keep load as close to body as possible. If 2 persons performing lift, ensure co-ordinated movements during lift. Avoid upper body/top heavy bending - do not lean forward/sideways. Clear the route before attempting the lift. If removing boiler from truck straddle the load and tilt forwards to facilitate secure grip. Ensure safe lifting techniques are used – keep back straight – bend using legs. Do not twist – reposition feet instead. Take care to avoid trip hazards, slippery or wet surfaces and when climbing steps and stairs. Always use assistance if required.

Carriage of carton from point of delivery to point of installation – roofspace.

Recommend 2-person lift. Ensure co-ordinated movements during lift. Avoid upper body/top heavy bending - do not lean forward/sideways. Clear the route before attempting the lift. Take care to avoid trip hazards, slippery or wet surfaces and when climbing steps and stairs. When transferring appliance into roofspace, recommend 1 person to be in roofspace to receive the appliance and other person to be below to pass up and support appliance. Ensure safe lifting techniques are used – keep back straight – bend using legs. Keep load as close to body as possible. Always use assistance if required. It is assumed safe access, flooring and adequate lighting are provided in the roof space. It is recommended a risk assessment of the roof space area be carried out before moving the appliance into the area to take into account access, stability of flooring, lighting and other factors, and appropriate measures taken.

Unpacking of appliance from carton.

Recommend 2 persons unpack appliance from carton. Always keep working area clear. Recommend cut base end of carton and open carton flaps, then tilt boiler forwards from its side onto its base and remove carton by sliding up over the boiler. Ensure safe lifting techniques are used – keep back straight – bend using legs. Keep load as close

to body as possible. Always use assistance if required. Dispose of packaging in a responsible manner. Recommend wear suitable cut resistant gloves with good grip to protect against sharp edges and ensure good grip when handling appliance outside packaging.

Positioning of Appliance for Final Installation – no obstructions.

This appliance is deemed to be a one person lift when removed from the carton. Fit bracket securely onto wall before lifting appliance into position. Obtain firm grip on front and sides of appliance, lift upwards, ensure stable balance achieved and lift upwards to position in place on bracket. Ensure safe lifting techniques are used – keep back straight – bend using legs - when lifting load from floor level. Do not twist – reposition feet instead. Keep boiler as close as possible to body throughout lift to minimise strain on back. Ensure co-ordinated movements to ensure equal spread of weight of load. Always use assistance if required. Recommend wear suitable cut resistant gloves with good grip to protect against sharp edges and ensure good grip when handling appliance.

Positioning of Appliance for Final Installation – above worktop, foreseeable obstructions etc.

This appliance is deemed to be a one person lift when removed from the carton. Fit bracket securely onto wall before lifting appliance into position. Obtain firm grip on front and sides of appliance, lift upwards, onto worktop if practicable. Ensure stable balance achieved and lift upwards to position in place on bracket. If 2 persons positioning onto bracket obtain firm grip at front and sides/base of boiler. Ensure co-ordinated movements during 2 person lifts to ensure equal spread of weight of load. Ensure safe lifting techniques are used – keep back straight – bend using legs - when lifting load from floor level. Do not twist – reposition feet instead. Keep boiler as close as possible to body throughout lift to minimise strain on back. Avoid upper body/top heavy bending - do not lean forward/sideways. Always use assistance if required. Recommend wear suitable cut resistant gloves with good grip to protect against sharp edges and ensure good grip when handling appliance.

Positioning of Appliance for Final Installation – within compartment etc. restricting installation.

This appliance is deemed to be a one person lift when removed from the carton. Fit bracket securely onto wall before lifting appliance into position. Obtain firm grip on front and sides of appliance, lift upwards, onto worktop if practicable. Ensure stable balance achieved and lift upwards to drop into place onto bracket. If 2 persons positioning onto bracket obtain firm grip at front and sides/base of boiler. Ensure co-ordinated movements during 2 person lifts to ensure equal spread of weight of load. If 1 person positioning onto bracket recommend obtain firm grip supporting base of boiler. Ensure safe lifting techniques are used – keep back straight – bend using legs - when lifting load from floor level. Do not twist – reposition feet instead. Keep boiler as close as possible to body throughout lift to minimise strain on back. Always use assistance if required. Recommend wear suitable cut resistant gloves with good grip to protect against sharp edges and ensure good grip when handling appliance.

Positioning of Appliance for Final Installation – in roof space restricting installation.

This appliance is deemed to be a one person lift when removed from the carton. Obtain firm grip on front and sides of appliance, lift upwards, ensure stable balance achieved and lift upwards to drop into place onto bracket. If 2 persons positioning onto bracket obtain firm grip at front and sides/base of boiler. Ensure co-ordinated movements during 2 person lifts to ensure equal spread of weight of load. If 1 person positioning onto bracket recommend obtain firm grip supporting base of boiler. Ensure safe lifting techniques are used - keep back straight – bend using legs - when lifting load from floor level. Do not twist – reposition feet instead. Keep boiler as close as possible to body throughout lift to minimise strain on back. Always use assistance if required. Recommend wear suitable cut resistant gloves with good grip to protect against sharp edges and ensure good grip when handling appliance. It is recommended a risk assessment of the roof space area be carried out before moving the appliance into the area to take into account access, stability of flooring, lighting and other factors, and appropriate measures taken.

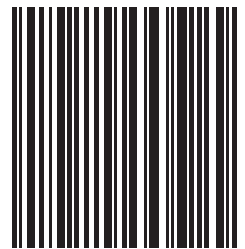

< 2000225262 >

Because of our constant endeavour for improvement, details may vary slightly from those shown in these instructions.