

INSTALLATION INSTRUCTIONS

Preliminary Notes Before Installation

This appliance is an Inset Live Fuel Effect appliance which provides radiant and convected warmth utilising the latest type burner technology.

The fire is designed to fit various types of fireplaces and natural draught flues as listed in the Installation Requirements.

The appliance must be installed by a competent person in accordance with Gas Safety (Installation and Use) Regulations 1998. It is strongly recommended that a CORGI registered engineer be used for this purpose.

Read all these instructions before commencing installation.

This appliance must be installed in accordance with the rules in force and only used in a sufficiently ventilated space.

The appliance is designed for installation on to a non-combustible hearth of at least 300mm depth.

This appliance are factory set for operation on the gas type, and at the pressure stated on the appliance data plate.

<i>Section</i>	<i>Contents</i>	<i>Page No.</i>	<i>Section</i>	<i>Contents</i>	<i>Page No.</i>
1.0	Important Notes	1	8.8	Fitting Fan Terminal	11
2.0	Appliance Data	2	9.0	Fuel Bed Layout	13
3.0	Installation Requirements	2	10.0	Fitting Frame and Front	14
4.0	Terminal Location	3	11.0	Testing & Commissioning	15
5.0	Site Requirements	4	11.1	Operating the Appliance	15
6.0	Ventilation	4	11.2	Spark Failure	15
7.0	Unpacking the Appliance	5	11.3	Setting Pressure	15
7.1	Component Checklist	5	11.4	Flue Monitoring System	16
8.0	Preparing for Installation	5	11.5	Testing for Spillage	16
8.1	Outer Wall Aperture	6	12.0	Briefing the Customer	17
8.2	Gas Supply Routing	6	13.0	Servicing	17
8.3	Installation Method 1	7	13.1	Cleaning the Coals	17
8.4	Installation Method 2	8	13.2	Dismantling the Burner Tray	18
8.5	Installation Method 3	9	13.3	Checking the Fan Assembly	18
8.6	Flue Preparation	11	13.4	Control Box Removal	18
8.7	Convactor Box and Tray	11	14.0	Troubleshooting Guide	19

1.0 IMPORTANT NOTES

This fire is an Inset Live Fuel Effect Gas Fire providing radiant and convected warmth. It is designed to operate on Natural Gas only.

It is the LAW that all gas appliances and fittings are installed by a competent person (such as a CORGI registered fitter) and in accordance with the Gas Safety (Installation and Use) Regulations 1998, the relevant British Standards for Installation, Codes of Practice and in accordance with the Manufacturers' Instructions. The installation shall also be carried out in accordance with the following regulations:

The Building Regulations issued by the Department of the Environment, the Building Standards (Scotland) (Consolidation) Regulations issued by the Scottish Development Department.

BS 5871 part 2

BS 5440 part 1

BS 1251

BS 6891

BS 6461 parts 1 and 2

BS 5482 part 1 (for LPG appliances)

BS 3456 part 201

BS-EN 60335-2-30

Note - For Republic of Ireland, reference should be made to the relevant standards governing installation, particularly in regard to flue sizing and ventilation. See IS813, ICP3, IS327 and any other rules in force.

Failure to comply with these regulations could lead to prosecution and deem the warranty invalid.

This appliance must be installed in accordance with the rules in force and used only in a sufficiently ventilated space.

Consult all instructions before installation and use of this appliance.

This appliance is free from any asbestos material. Refractories and coal bed are constructed from ceramic fibre.

2.0

APPLIANCE DATA

Gas Group	G20 Natural Gas CAT 12H
Inlet Pressure	20 mbar
Max Energy Input (gross)	6.2 kW
Min Energy Input (gross)	3.5 kW
Pilot Energy Input (gross)	210 W
Setting Pressure	17.5 mbar
Main Injector Burner	Stereo size 78
Gas Inlet Connection	8mm compression
Ignition	Piezo spark
Spark Gap	3.5 to 4.5mm
Electrical Supply	230V~50Hz
Current Rating	0.3A running, 0.4A on start up
Fuse Rating	3 Amp
Weight	Fire Unit 20Kg, Fan Unit 12Kg
Flue Specification	Twin walled circular section flue tube provided with appliance. No additional or alternative flue may be used. Outer flue tube diameter 120mm

See Data Badge affixed to appliance for current data.

This appliance is for use only with the gas type, and at the pressure stated on the appliance Data Badge, and is for decorative purposes.

3.0

INSTALLATION REQUIREMENTS

Compatible wall thicknesses for the Installation Methods detailed in this Guide are as follows;

* These dimensions allow for 25mm Rockwool insulation jacket, other forms of insulation may require adjustment.	Ashleigh Plus		Kensington/Reality	
	Min.	Max.	Min.	Max.
Surface mounted firebox/surface mounted fan terminal.*	75mm	570mm	70mm	570mm
Surface mounted firebox/recessed fan terminal.*	160mm	660mm	160mm	660mm
Recessed firebox/surface mounted fan terminal.	220mm	720mm	175mm	675mm
Recessed firebox/recessed fan terminal.	310mm	810mm	265mm	765mm

Note: These dimensions are between the surface of marble/backpanel and the surface of the outer wall.

Internal

This appliance MUST NOT be installed into a room containing a bath or shower, or where steam may be present. The firebox must be installed onto a suitable non-combustible insulating surface at least 12mm thick, covering the entire base area of the box. This appliance is suitable for use with a "lightweight" surround and back panel of 150°C minimum rating. A suitable gas supply and an electrical 3 Amp fixed fused spur are both required near the intended appliance site.

External

Please refer to the diagram on the following page for more details of the most suitable site for the fan terminal. The terminal must be located so that the outlet is not obstructed in any way allowing poor disposal of combustion products. The safety cage should be fitted in place over the terminal to ensure compliance with Byelaws. Terminals located in passageways between two properties, public footpaths or which might discharge over the same may be subject to local Byelaws on items such as minimum distances for projection. In these circumstances it is the installers responsibility to check that the location of the terminal does not infringe any Bye Laws. If in any doubt about flue terminal location, especially with regards to garages and car ports then further advice should be sought from CORGI or the manufacturer.

4.0 INSTALLATION REQUIREMENTS (continued)

Avoid locating the terminal in close proximity to combustible materials, such as plastic drainpipes and fences. If these are impossible to avoid, then a suitable metal deflector must be used if the flue gases begin to heat the object. For minimum standard dimensions of clearance see below.

Covered areas such as under car ports should be avoided but if no alternative is practical the following notes should be adhered to; The covered area should have at least two open sides (i.e. a roof and ONE supporting wall). If more than one side is filled, then advice must be sought on the location's suitability. Any openings into dwellings such as doors, windows and air vents under the covered area must be at least 1200mm away from the terminal position. If the roof is constructed from plastic material, great care must be taken with the installation as there is no simple method of protecting this type of roof from heat build up.

4.0 TERMINAL LOCATION

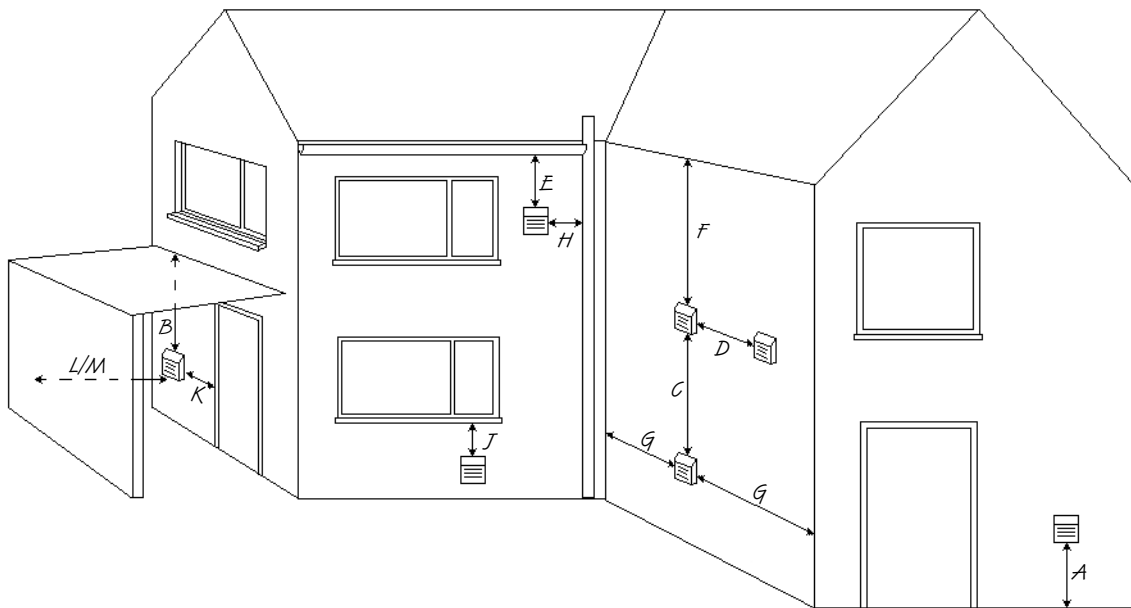

Minimum location distances

- A - 200mm above ground level.*
- B - 200mm below balconies or car ports.
- C - 1500mm vertically between terminals.
- D - 300mm horizontally between terminals on same wall.
- E - 75mm below gutters, soil pipes or drain pipes.
- F - 200mm below eaves.
- G - 300mm from internal or external corners
- H - 75mm from vertical drain pipes.
- J - 300mm directly below an openable window or other opening e.g. air vent.
- K - 1200mm from an opening into the building under a car port.
- L - 600mm from a surface facing the terminal.
- M - 1200mm from another terminal facing the terminal.

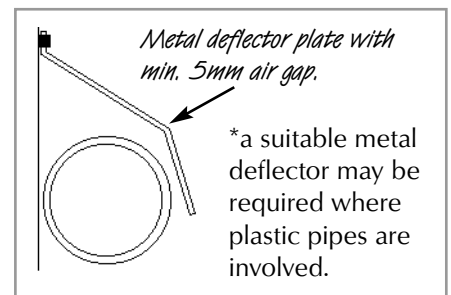

Care should also be taken with the terminal location relative to nearby plants, grass, or trees as the gases expelled may be hot enough to damage them. At least 1000mm clearance is recommended.

Note: Dimensions relate to exhaust outlet at the base of fan terminal box.

5.0 SITE REQUIREMENTS

For aesthetic purposes it is essential that the hearth and infill plinth area are flat and level. The hearth and infill must also be square to the back panel. Failure to comply with this could cause the appliance to lean away from the fireplace resulting in an unsatisfactory installation.

The electrical earth to the property and all wiring must be carried out in accordance with IEE Wiring Regulations (including any Local Regulations). If you are unsure about this aspect, then professional advice should be sought. This appliance is suitable for use with a 230V~50Hz (AC) single phase (normal domestic) electrical supply. Connection to the mains supply should be made with the three core cable (green/yellow - earth, blue - neutral, brown - live) to a fixed fused spur with double pole insulation (minimum 3mm separation of poles) and fused at 3 amp. Take care not to pull or damage the internal wiring to the fan unit during installation. Should the mains cable become damaged at any stage, it should only be replaced with the manufacturers supplied cable (part no. EL006090/0). Failure to use a genuine spare could cause a hazard.

WARNING! THIS APPLIANCE MUST BE EARTHED.

If a concealed gas supply is to be used, the supply pipe must be sleeved through walls and floors. If the fire is to be inset into the cavity leaf, only factory sleeved pipe should be used. For further details see relevant section. A separate isolation device must be incorporated into the incoming gas supply to facilitate servicing. No more than 1.5 metres of 8mm pipe should be used in the connection of the gas supply to the appliance, as more could result in an unacceptable drop in pressure.

This appliance must only be installed onto a non-combustible wall or surface. The fire requires a hearth with a non-combustible surface at least 12mm thick. The top surface of the hearth must be at least 50mm above floor level, or be surrounded by a raised edge or fixed fender of at least 50mm high. The non-combustible hearth must extend a minimum of 300mm in front of, and 150mm either side of the live part of the appliance. The hearth must be a minimum of 680mm wide.

The appliance must be installed by one of the following methods;

- 1 - Fitment against an existing inner house wall with a suitably constructed fireplace and/or false chimney breast to enclose the depth of the fire.
- 2 - Insertion into a purpose made opening in the inner leaf of a cavity wall or disused fireplace opening and with the use of a suitable fireplace. ***Note: The appliance should not bridge the cavity - any overhang must be kept to a minimum, and the installation instructions must be adhered to. Building Control requirements may vary in some areas, enquiries should be made accordingly.***
- 3 - Installation into a timber framed dwelling using the clearances to combustible materials shown in the relevant section. Building Control requirements vary in some areas, enquiries should be made accordingly.

An unprotected combustible shelf may be fitted above the appliance, provided it complies with the minimum dimensions stated below. Protective materials may be used to deflect heat from shelves that are too low. A non-combustible shelf may be fitted to within 10mm of the top edge of the fireframe. Combustible materials,

<i>Maximum depth of shelf</i>	<i>Minimum distance from inside edge of fire frame to underside of shelf</i>
100mm (4in)	203mm (8in)
150mm (6in)	305mm (12in)
203mm (8in)	356mm (14in)

such as wood, may be fitted to within 100mm (4in) of either side of the frame of the firebox providing it projects no further forward than 100mm (4in). As with all heating appliances, decorations, soft furnishings and wall coverings (such as blown vinyl, flock and embossed paper) may discolour or scorch if positioned too close to the fire. If the appliance is fitted to a dry-lined wall, the gap between the plasterboard and blocks must be sealed with non-combustible material, and any un-plastered board replaced with Superlux or other suitable non-combustible material if in direct contact with the appliance.

6.0 VENTILATION

No purpose provided ventilation is normally required with this appliance. However, the ventilation requirements of other gas appliances in the same room or space should be taken into consideration. A spillage test should be carried out as described in the relevant section with the doors and windows both open and closed, and with any extractor fans running on full. Where fitted, ventilation must comply with the requirements of BS 5440 part 2. Vents fitted beneath or in the immediate vicinity of the appliance must not be used as they may adversely affect the performance of the ODS pilot.

Note: For Republic of Ireland the ventilation requirements may differ. Check local Installation codes.

7.0 UNPACKING THE APPLIANCE

Stand the carton right way up, cut the strapping bands and remove the top end cap. Read all the instructions before continuing to unpack or install this appliance.

Remove the box containing the cast front fret, and the bag containing the coals. Remove the cardboard packing pieces, and any bags containing other fittings or parts. When all loose parts have been removed, the outer sleeve may be lifted off to reveal the appliance.

Check that the components supplied correlate with the checklist given in section 7.1.

Please dispose of the packaging materials at your local recycling centre.

7.1 COMPONENT CHECKLIST

Box 1 - Fire carton		Box 2 - Fan carton	
QUANTITY	DESCRIPTION	QUANTITY	DESCRIPTION
1	Convection box and burner tray assembly	1	Complete fan assembly
1	Decorative fireframe - Ashleigh only	1	Twin-walled tubular flue
1	Cast front fret with ashpan door - Ashleigh only	1	Rockwool rear fire jacket
1	Moulded ceramic fibre combustion matrix	1	Terminal guard cage
15	Moulded ceramic coals		
1	Set of brick panel and side cheeks	Box 3- Cast Fire Casing	
1	Set of manufacturers instructions/guarantee form	QUANTITY	DESCRIPTION
1	Bag of fixings (8 rawl plugs, 8 No8x1.5 screws)	1	Kensington/Reality cast
3	Lengths of sealing strip.	1	Ashpan door for above
1	Deflector baffle		

8.0 PREPARING FOR INSTALLATION

Remove the fire tray from the convector box by removing the two securing screws in the front legs of the tray, and inverting the tray onto the hearth. Carefully unplug the safety solenoid on the tray from the control box by squeezing the clips on the three way connector and easing apart. Place the tray safely to one side along with the fuel bed components, firefront and decorative frame.

Apply the self adhesive sealing strip to the rear perimeter of the firebox frame, this will eventually seal the firebox to the fireplace back panel. Place the fire to one side while the site is prepared for flue installation.

Mark the vertical centreline of the desired location of the appliance after first checking for clearances to pipes and cable in the wall and also the terminal position outside.

Note: The length of the centreline will be 432mm PLUS the thickness of the hearth for the Reality/Kensington appliance; 442mm for the Ashleigh Plus.

Mark the position of the 30mm cable hole in relation to the flue centreline. Using a suitably long masonry bit, drill through both leaves of the cavity wall. Check outside that the clearances from the hole are adequate for installation to proceed. Check all dimensions with the diagram in the relevant section. Drill the 30mm cable hole in the wall.

8.0 PREPARING FOR INSTALLATION (continued)

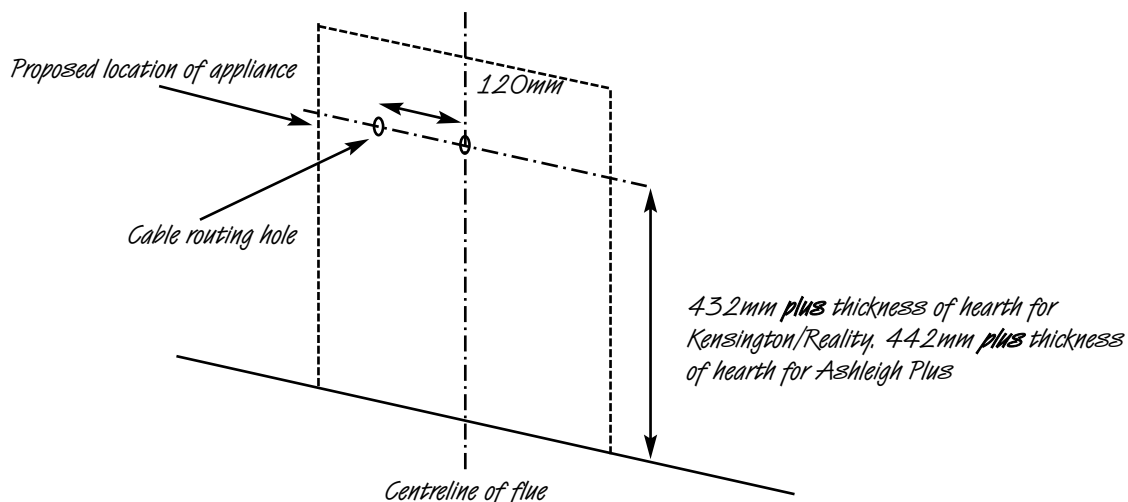

8.1 OUTER WALL APERTURE

From the outside of the property, open up the pilot hole in the external leaf of the cavity to the required size.

If the fan terminal is to be mounted directly onto the outside wall, the hole should be opened up to a 125mm diameter aperture centred around the pilot hole.

If the fan terminal is to be recessed into the outer leaf, the hole should be opened up to the dimensions given in the diagram.

Clear all the brick rubble and debris that may have fallen into the cavity. If the cavity wall insulation is obstructing your view of the inner leaf then clear this back.

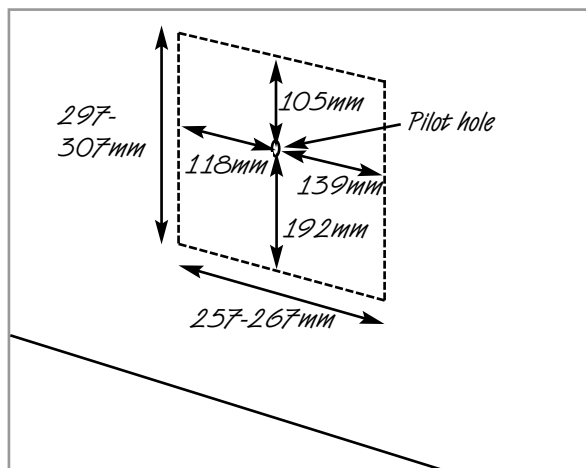

8.2 GAS SUPPLY ROUTES

The gas supply may enter the appliance across the hearth or through the 'knock outs' provided in the rear of the firebox. Gas pipes should not be buried or routed through walls without being protected by conduit or sleeving. An isolation tap must be included in the gas connection pipe to facilitate servicing.

Note: Any fittings used under the appliance must be rated to 80C and must not come into contact with the underside of the tray.

For INSTALLATION METHOD 1, the gas supply can be run in the conventional manner taking due account of rules and regulations.

For INSTALLATION METHOD 2, use only factory sleeved pipe in a continuous unjoined length in the cavity of the wall and area which communicate with the cavity. Ensure a good seal where the pipe enters through the appliance grommet. This is a permitted gas supply routing

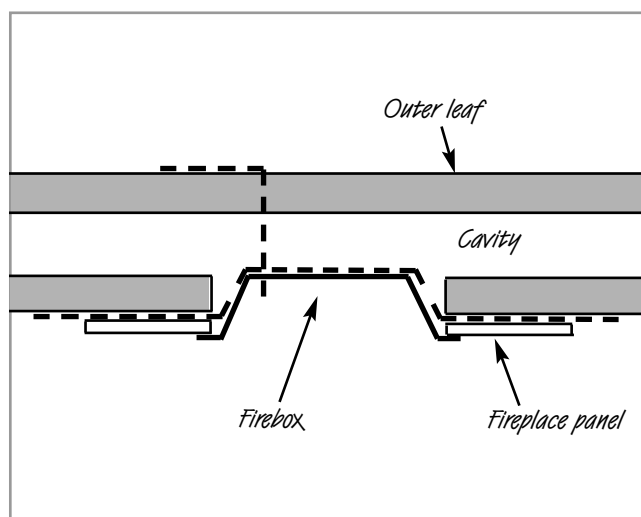

8.3 INSTALLATION METHOD 1

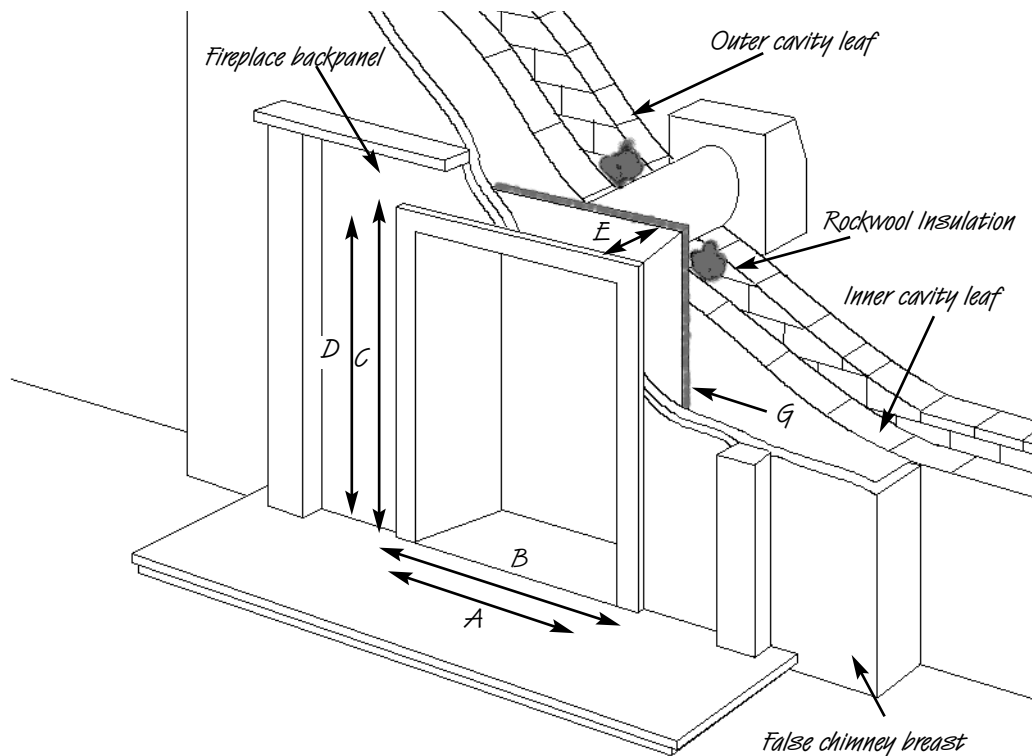

Italics refer to Ashleigh Plus model

A- Opening width: 300mm min. 460mm max. **380mm min 450mm max.**

B- Overall width: 510mm. **490mm**

C- Overall height (exc hearth): 615mm. **590mm**

D- Opening height: (exc hearth): 505mm min. 570mm max. **540mm min. 580mm max.**

E- Recessed depth of fire: 80mm. **125mm**

F- The hearth must extend 300mm in front of the appliance, with its top surface 50mm above the surrounding floor level or having a 50mm high fixed fender around its perimeter.

G- Space allowed for Rockwool jacket: 25mm

This method requires no modification to the property's wall and is achieved utilising either an extended firesurround or by constructing a shallow false chimney breast of a minimum 80mm (125mm for Ashleigh) deep. See diagram for further dimensions.

Centering on the pilot hole already drilled, create a hole from inside the property 125mm diameter. If loose fill cavity wall insulation is fitted to the property it will be necessary to seal the wall cavity where the flue opening is formed to prevent insulation material coming into contact with hot surfaces of the fire and its components. The recommended method is to pack a depth of 50-100mm into the cavity with Rockwool or a similar non-combustible insulation material.

Where the property does not have existing cavity wall insulation, it is recommended that a space 50-100mm into the cavity is packed with Rockwool or similar material, to prevent any future installation of cavity wall insulation from coming into contact with hot areas of the appliance.

At this point the false chimney breast or firesurround should be installed.

Note: When constructing the stud partition, all uninsulated, combustible material must be kept a minimum of 75mm away from the fireplace. Combustible materials closer than 75mm MUST be protected with a minimum of 25mm insulation material.

8.4 INSTALLATION METHOD 2

Set out where possible centrally beneath a block join as shown. Use a core drill frill for guide holes, and a 'shark saw' or angle grinder to form an opening to suit the lintel.

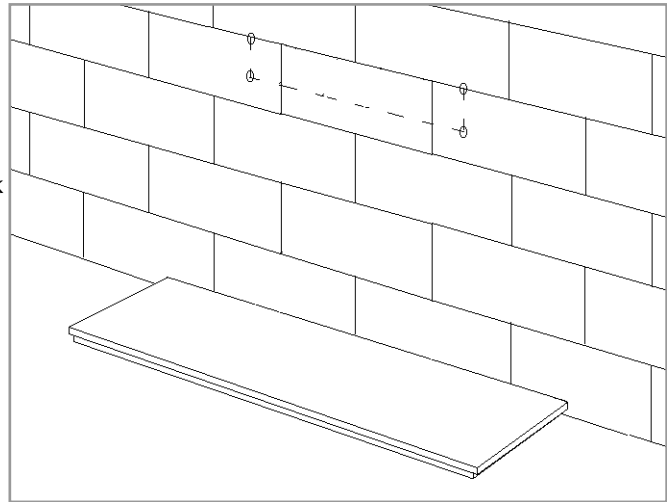

The lintel should be inserted and securely slate pinned, leaving the wall above safe and firm.

Note: Always bed on mortar, DO NOT dry bed.

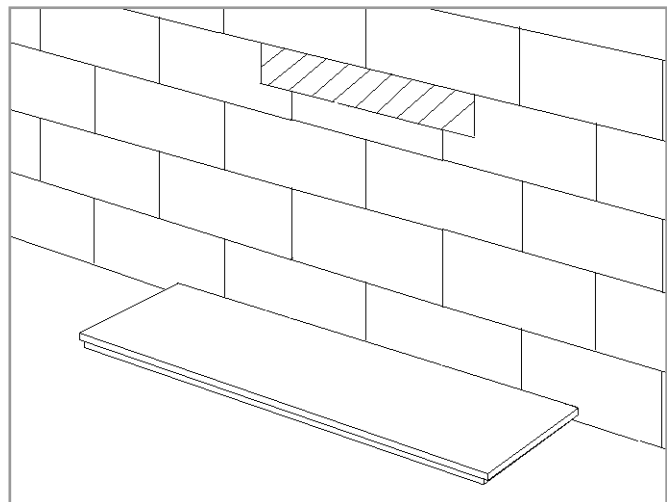

Remove all masonry from below the lintel, and clear debris from the cavity.

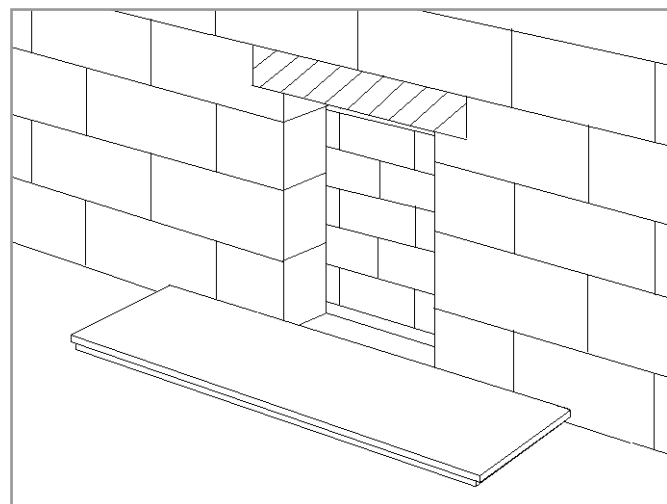

The top of the exposed cavity must be sealed with Superlux board or a similar non-combustible material. The board should be fixed at an angle, lower at the back, so as to direct any moisture coming down to the outside wall. This board should be fixed with screws, Unibond, or a similar adhesive. It is important to fit this board or a cavity tray to protect the property and appliance from drips of water. The sides of the opening where the cavity is exposed should be packed with Rockwool or similar non-combustible material to a minimum depth of 50mm. The Rockwool packing must extend from the base of the opening to the Superlux board.

The non-combustible hearth should now be formed or secured in place.

8.4 INSTALLATION METHOD 2 (continued)

It is essential the Rockwool pad be fitted to the rear of the appliance to prevent condensation and to insulate the appliance's heat exchanger from the cold air of the cavity.

Note: Neither the appliance nor the Rockwool insulating pad should bridge the cavity space. Consult your local Building Control Department for any additional construction requirements for further advice.

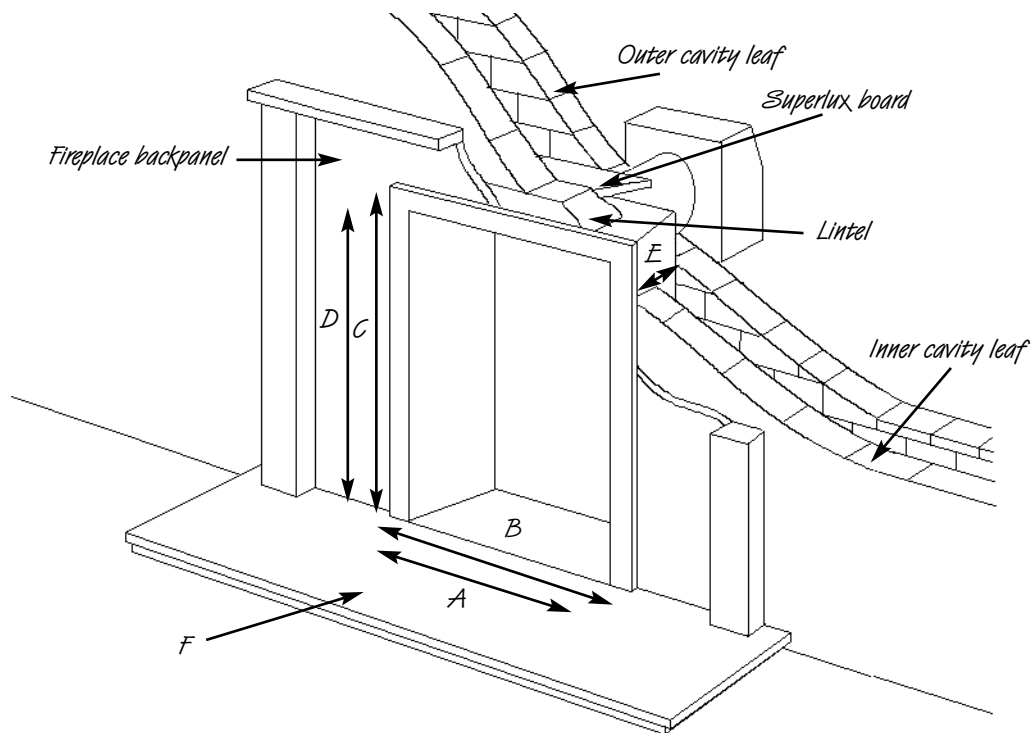

Italics refer to Ashleigh Plus model

A- Opening width: 300mm min. 460mm max. **370mm min, 450mm max,**

B- Overall width: 510mm. **495mm**

C- Overall height (exc hearth): 615mm. **590mm**

D- Opening height: (exc hearth): 505mm min. 570mm max. **540mm, 580mm max.**

E- Recessed depth of fire: 80mm, **125mm**

F- The hearth must extend 300mm in front of the appliance, with it's top surface 50mm above the surrounding floor level or having a 50mm high fixed fender around it's perimeter.

8.5 INSTALLATION METHOD 3

Installation into timber framed dwellings

Where removal of any part of the inner timber leaf of the wall is involved, the structural integrity of the wall must be maintained and the advice of your local Building Control Department should be sought. If the property is under any N.H.B.C. cover, it is advised that there advice on this modification should also be sought.

Either of the two preceding methods of installation may be adapted for use in timber framed buildings, proving extra care is taken to prevent combustible materials from contact with hot surfaces.

The appliance must be installed in accordance with British Gas document DM2 and DM3, or the Institute of Gas Engineers published procedure IGE/UP/7

Special attention must be paid to the location of the studwork frames of the inner leaf and the appliance positioned accordingly. Wires and pipes that run within the inner timber leaf must also be located and taken into account when positioning the appliance.

8.5 INSTALLATION METHOD 3 (continued)

Installation using extended fire surround or false chimney breast.

When using this method of installation the following amendments should be incorporated.

25mm clearance must be allowed from the appliance firebox to any insulated combustibles. 75mm clearance must be allowed to any unprotected combustibles. 50mm minimum thickness of insulation should be provided around flue pipe and gather hood. Where the flue pipe passes through the inner leaf, a hole 100mm larger than the flue should be cut to allow 50mm air gap around the entire flue circumference.

The vapour barrier on the back of the inner leaf should be cut and carefully fixed to prevent any ingress of damp into the plasterboard layer. A layer of insulation will need to be provided to insulate the surface of the inner wall from the heat effect of the flue. It may be advantageous to use a sheet of Superlux board for this purpose.

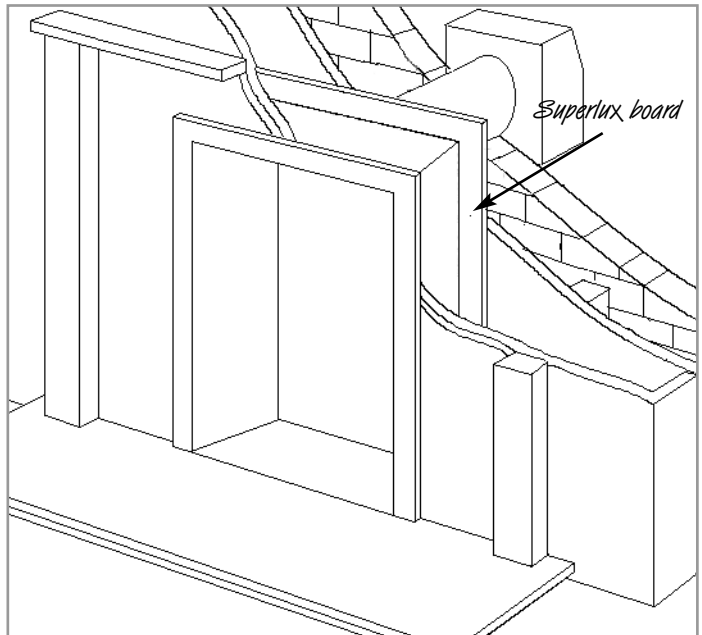

Installation by setting the appliance into the inner leaf of wall.

When setting the appliance into the inner wall find a suitable position between the wall panel frames and carefully open up a hole to the dimensions given in the relevant section, paying careful attention to securing the damp proof membrane back into position. A drip collar of galvanised or stainless steel should be formed with the twisted joint on the underside of the flue to disperse drips.

An air gap of 75mm between all hot surfaces and the surrounding wall should be allowed, if protective insulation is used this may be reduced to 25mm clearance. The exposed cavity should be sealed off using Superlux or a similar non-combustible board, see below.

Note: *Neither the appliance nor the Rockwool insulation should overhang the cavity space.*

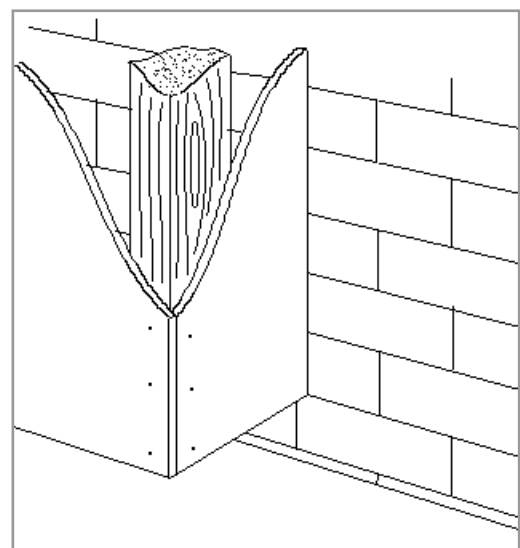
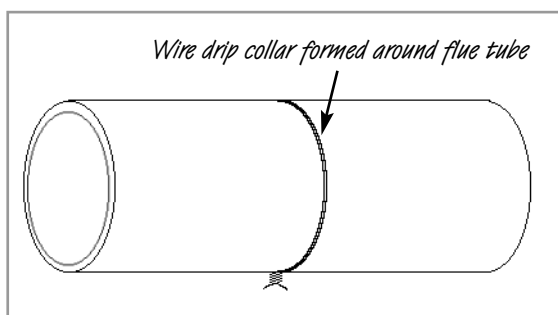

8.6 FLUE PREPARATION

When all the preparation work has been completed for whichever method of installation has been chosen, and with the firesurround fitted, take the appliance and slide the round flue section over the spigot on the rear of the fire. Protect any decorative hearth with a dust sheet or similar, place the appliance in position with the flue section protruding through the wall(s) to the outside. Make sure the firebox is fully pushed home before marking two fixing holes in the floor of the firebox. Outside the property, mark a line on the flue tube level with the outer surface of the wall, where it protrudes through.

Remove the firebox from the location and slide off the flue section. If the fan terminal is to be mounted directly on the outside wall, cut the flue tube to length along the marked line. ***If the terminal is to be recessed into the outer wall, a second line should be marked 85mm back towards the appliance.*** The flue tube should then carefully be cut to length along the relevant line. Do not remove the ceramic insulation. File off any rough edges and slide back on to the appliance spigot ensuring the 'O' ring remains seated in its channel. Slide the Rockwool jacket into place over the flue section, this may be secured with aluminium tape.

With a suitable drill, make the two previously marked holes in the floor of the firebox, drilling down through into the non-combustible hearth. Fit two rawl plugs into the holes.

8.7 CONVECTOR BOX AND BURNER TRAY

The two metre mains electrical cable exits from the rear of the appliance and the FIXED FUSED SPUR (fused at 3 Amp) should be arranged to allow easy connection.

Stand the appliance in front of the opening and feed the fan wiring harness through the hole drilled in the wall. You may find this easier if a short length of plastic conduit is first fitted to the hole. The cable must run outside of the insulating jacket, and be arranged so that it does not touch any hot surfaces. Feed the mains cable through to the location of the fixed fused spur. Depending on the location of the 8mm gas supply, feed through the back of the firebox and fit the grommet seal (if applicable). Now carefully slide the appliance back into position and secure into place using the two previously drilled holes. Ensure the flue unit has passed correctly through the wall.

Note: If using an exposed gas supply, the route of the pipe should be located through the purpose provided cutouts on the decorative casing of the appliance.

Place the burner tray near to the firebox and connect the three-way plug from the control box to the safety solenoid mounted on the tray. Connect the gas supply to the entry point on the gas valve. Secure the burner tray into position with the two screws through the tray legs.

8.8 FITTING THE FAN TERMINAL

The external fan terminal can now be fitted. This comprises three parts, the wall fan box section, the cover, and the trim frame (only used for recess mounting). Remove the four screws securing the terminal cover, and lift it away, placing safely to one side. At this point, the trim must be fitted to the fan box if the terminal is to be recessed into the wall. Remove the four self tapping screws from the sides of the box, and slide the trim frame over the box with the fixing flanges facing into the wall. Secure with the four screws and proceed to fit the terminal as described below.

Offer up the fan unit and feed the connecting cable through the entry hole in the wall plate. It may be advantageous to remove the rubber grommet in the entry hole to aid the insertion of wires and refit afterwards. Remove the connectors through the entry hole, then the grommet, before refitting the grommet to the entry hole.

Note: The grommet MUST be refitted in order to prevent damage to the fan wiring harness.

Installing the fan terminal by surface mounting to the outside wall

Slide the fan unit on to the previously installed flue pipe. Mark the four fixing screw positions on the wall, and drill the 5mm securing holes into the brickwork. Affix the fan terminal to the wall with the rawl plugs and screws provided. A bead of silicone weather sealant, or similar suitable sealant should be applied along the top edge, and down the two sides of the terminal where it meets the wall, to prevent the ingress of water. Any excess sealant should be wiped away to enable correct fitment of the terminal cover.

8.8 FITTING THE FAN TERMINAL (continued)

Fitting the fan terminal by recessing into the outer wall

If already fitted, remove the four long M4 screws from the top and bottom of the fan terminal. Fit the terminal into the wall opening previously prepared, ensuring the flue tube seats correctly over the terminal spigot. When correctly fitted, insert the four screws into the threaded inserts fitted to the inside of the top and bottom of the terminal. Using a suitable screwdriver, continue to wind in the four screws from the inside of the box until the fan terminal is held securely in the opening. Alternatively, four holes may be marked in the sides of the fan terminal, and these drilled through into the brickwork. The terminal can then be secured with rawl plugs and screws. Apply a bead of silicone weather sealant, or similar suitable sealant around the top and side edges of the frame to provide a good seal to the wall, eliminating water ingress.

Note: *The recessed fan terminal MUST NOT be cemented in place within the outer wall. The louvres in the sides of the fan terminal MUST be allowed to vent to the cavity to aid cooling of components contained within*

With the terminal fixed into position the wires may now be connected. Attach the green earth wire to the screw securing the fan earth wire. Fit the two three way connector to the relevant connectors from the fan unit and pressure switch. Check that none of the wires can come into contact with hot surfaces or moving parts of the fan. Use the cable tie supplied to secure the wires to the terminal. With all the cables properly connected, fit the terminal cover ensuring the fan outlet is clear, and secure with the four screws provided. Offer the wire terminal guard cage into position, mark and drill the relevant mounting holes, and secure into place using rawl plugs and screws. The terminal guard must be fitted at all times to comply with any Byelaws in force.

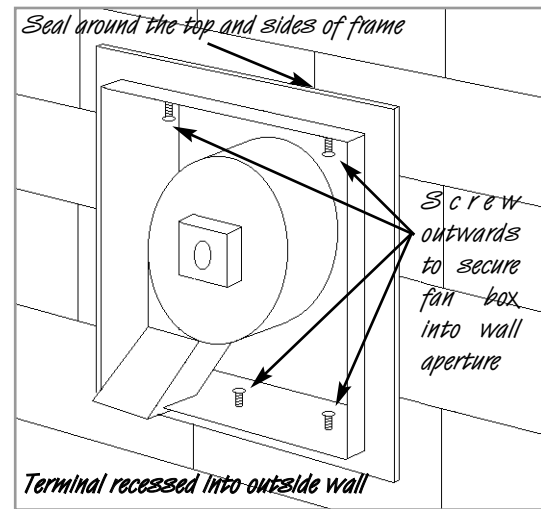
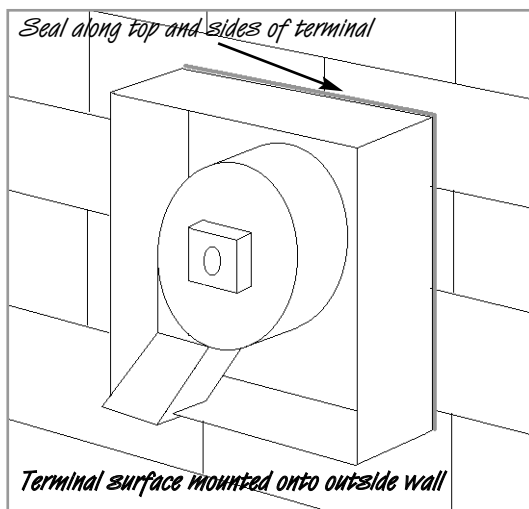

Schematic wiring of fan unit

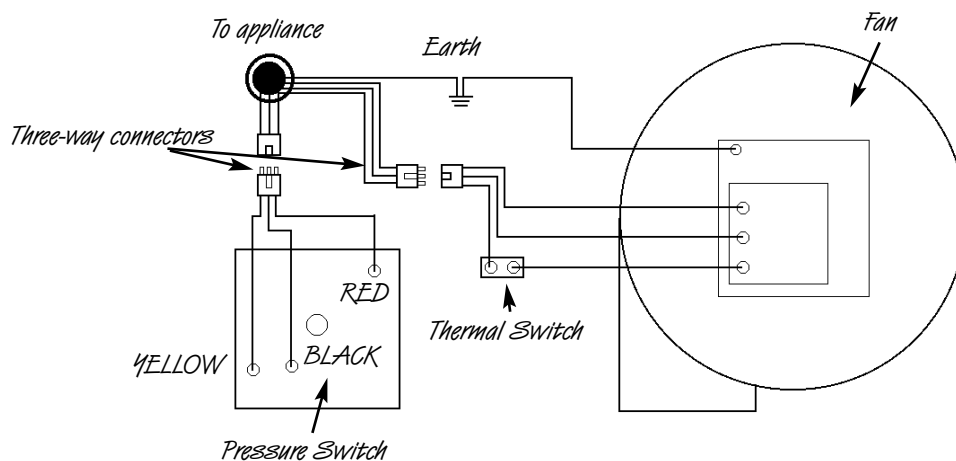

9.0 FUEL BED LAYOUT

Place the brick panel against the rear of the firebox.

Place the matrix into position as shown. Slide the ceramic side cheeks into position.

Place the front row of six coals onto the matrix, with the two coals second from each end turned on their edges. Ensure the end coals are firmly against the side cheeks as shown in the photograph. Ensure rear edges of coals do not protrude into the flame ports, pull forward if necessary.

Place the rear row of four coals, making sure that the flat sides are firmly against the brick panel and side cheeks as shown.

Place the middle row of five coals onto the flats in the matrix. Ensure that the coals do not cover the holes in the matrix. Place the two end coals firmly against the side cheeks and back onto the steps on the matrix, turning them on their sides as shown. These coals **MUST NOT** be allowed to fall into the flame slots in the matrix, and **MUST** have gaps between them to allow flames through.

9.0 FUEL BED LAYOUT (continued)

The edges or corners of the front row of coals **MUST NOT** be allowed to enter the flame slots in the matrix. If in doubt, pull them forward as far as possible. The best results can be achieved with a well laid, generously spaced coal layout throughout the firebed.

DO NOT place coals into holes in the matrix, allow the holes to become obscured, or cram the coals together.

Coals may be rotated slightly within their locations to give a good visual effect. Attention should be paid to finally arrange the coals with the fire lit and running on HIGH to ensure no flames play on the firebox sides. This will reduce the possibility of heat discolouration.

The fire is designed to operate correctly with the coals supplied when assembled according to these instructions. Never add to the fifteen coals or change them for a different type. **NEVER** throw rubbish or other matter onto the coal bed.

10.0 FITTING THE DECORATIVE FRAME AND FRONT

Kensington/Reality

An outer case section and ashpan door are supplied in Box 3.

Fit the blanking plate to the cutout in the top right side of the casting. Place the casting assembly onto the location lugs on the top face of the convactor frame. The casting assembly can then be secured with the two long No8 screws through the holes in the front face of the casting (behind the ashpan door). Do not overtighten, screw in until casting contacts the firebox.

Ensure the casting is square and level to the backpanel. Make adjustments where necessary to achieve squareness.

Ashleigh Plus

The appliance is supplied with a decorative frame in a variety of finishes. The frame is held onto the firebox by one of two methods; either by magnetic pieces fitted to the steel backing plates, or as a three piece clip-on assembly. If not pre-fitted, the clip-on frame pieces should be hooked over the outer edges of the fireframe, and pushed firmly home. The sides should be fixed first, followed by the top bar, which overlaps the sides. Push firmly home. A plastic protective film may be applied to the outside of the frame and should be removed at this stage.

Place the decorative firefront in front of the fire and slide the ashpan door into place. The firefront shown in these instructions may be different to the one supplied with the appliance.

The decorative hood is fitted by aligning the four mounting tabs with the relevant slots in the functional hood of the firebox. Press inward and down to secure.

11.0 TESTING AND COMMISSIONING

Turn on and test the gas supply up to the fire for any leaks, in accordance with current Approved Codes Of Practice (ACOPs).

When the appliance is first used, protective oils coating the firebox may burn off. It is advisable to ventilate the room during this period, at least one hour.

11.1 OPERATING THE FIRE

Turn on the power supply and momentarily press the ON switch on the control box. The fan should operate with the warning light illuminated. Almost immediately the fan will slow down to operating speed and a click may be heard as the safety solenoid opens allowing gas to the burner unit. The warning light on the control box should extinguish.

The pilot is visible through the left hand coal, re-arrange for good viewing if necessary. Push in and turn the control knob to the SPARK position, and hold there for a few seconds.

Continue turning anti-clockwise through the spark click to the PILOT light position, ensuring the pilot has lit. If not, return the knob clockwise, and repeat.

When the pilot lights after the spark, keep the knob depressed for approximately ten seconds. Now release the knob and the pilot should stay alight. If not, retry ignition. If the pilot is extinguished DURING USE, wait three minutes before repeating the ignition procedure.

To achieve the HIGH setting, push the control knob in slightly and continue turning anti-clockwise to the high position. The main burner should light after a few seconds. To decrease the setting to LOW, turn the control knob clockwise to the low setting. To turn to the PILOT position from the HIGH or LOW positions, press the control knob in, and return to the pilot position and release. To turn the fire OFF, keep the knob pressed in, return to the off position and release. Press the OFF button on the control box to switch off the fan.

11.2 SPARK FAILURE

The gap between the spark electrode and the pilot should be 3.5 - 4.5mm to produce a good spark. There should be no need to adjust this. If under any circumstances the electric spark fails, the pilot may be lit manually by proceeding with the ignition sequence as previously described, and after turning the control knob through the spark position, the knob should be held in and the pilot lit with a taper.

11.3 SETTING PRESSURE

Remove the screw from the pressure test point, situated on the main injector pipe by the pilot, and attach a U gauge. Light the fire on the HIGH setting. The setting pressure should be in accordance with the figures stated on page 2 of these instructions. The fire is factory set to achieve these pressures, and any significant variation could indicate a supply problem. If the pressure is too high, the gas supply meter may be set incorrectly. This should be checked with the fire running and if necessary reset by the gas supplier.

11.3 SETTING PRESSURE (continued)

If the pressure is too low, then check the meter governor pressure with the appliance running. If this is incorrect it will need to be reset by the gas supplier. If the setting pressure is too low, but the meter pressure is acceptable, then a problem in the supply pipework is to be suspected. This will be dirt and debris, kinked or inadequate size pipes, restriction in a fitting or solder flashing across a joint.

Note: you will not get an accurate reading of the inlet pressure with a pressure gauge on the end of the supply pipe - this is the static pressure in the system. You must use a 'T' piece and measure the supply pressure with the fire on High - the dynamic pressure.

11.4 FLUE SPILLAGE MONITORING SYSTEM

This fire is fitted with a flue spillage safety device (ODS). If the fire shuts down during use for no apparent reason then several things may be suspected. If a door or window has been opened creating a draught, then pilot disturbance is the problem, and removal of the draught should resolve this. If a grommet seal has been left out of the firebox then this also will also cause intermittent shutdown (recall your installer to fit). The gas pressure reaching the fire must also be checked (again, recall your installer to check and rectify any problem). The thermocouple connection into the back of the gas control valve may also have worked loose during installation, simply get the installer to tighten.

If pilot disturbance is not the cause, then the ODS safety system may be in operation. Switch the appliance OFF, check the flue and carry out any remedial work required. Relight the fire and carry out a spillage test. DO NOT allow the appliance to be used if it continues to fail a spillage test. The aeration hole of the pilot must be carefully cleaned out on each annual service to ensure continued function of the ODS. The spillage monitoring system shall not be adjusted, modified, or put out of operation by the installer. Any spare parts fitted MUST be of a type supplied for the purpose by the appliance manufacturer. If the fire is not spilling, then further guidance should be sought, using the Troubleshooting section as a guide.

11.5 TESTING FOR SPILLAGE

Close all doors and windows to the room containing the appliance. Let the fire run on HIGH for five minutes. Take a smoke match, light it, and using a smoke match tube, hold it at the top edge of the fire opening, 25mm down and 25mm in. Starting 50mm in from either side, run the smoke match across the opening. All the smoke should be drawn away into the flue. Any smoke returning into the room indicates that spillage is occurring. If the initial test fails, run the fire for a further 10 minutes and repeat the test. When the test has been completed satisfactorily, repeat with any extractor fans in the premises running on the highest setting, and any communicating doors open. Finally, repeat with all doors open.

NOTE: If spillage is still indicated after undertaking all of the above, there may be a problem with the flue setup, or insufficient ventilation is present.

If the problem cannot be rectified immediately, then expert advice should be sought. Inform the user, disconnect the fire, and attach an explanatory label.

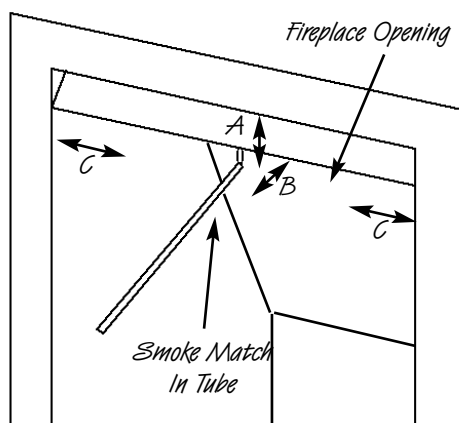

A. 25mm down from top of opening
B. 25mm in from front of opening.
C. Disregard outer 50mm either side of fireplace opening

16

Cross section of smoke match tube

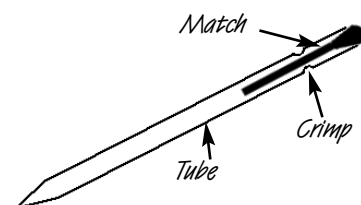

Make a smoke match tube from 10mm diameter tube. Seal off one end and crimp the tube to prevent the smoke match from sliding down inside.

12.0 BRIEFING THE CUSTOMER

All instructions must be handed to the user for safekeeping. *Show the customer how to light and control the fire.*

After commissioning the appliance, the customer should be instructed on the safe use of the appliance and the need for regular servicing. Frequency of service depends on usage, but MUST be carried out at least one annually.

Scratched and other superficial damage to the matt black paintwork of the appliance can be covered with matching heatproof spray. Use only the manufacturers' recommended spray paint. Paint only when the fire is OFF and cold. Always mask off the surrounding area to prevent contamination with overspray. Ventilate the room during the use of the spray.

DO NOT attempt to spray paint the coals or ceramics, or wash them in water.

13.0 SERVICING

Isolate the fire from the gas supply. Ensure that the fire is fully cold before attempting service. A suggested procedure for servicing is detailed below.

1. Lay out the dust sheet and tools.
2. Disconnect electrical supply, and isolate gas supply.
3. Carefully remove the firefront casting, and ceramic components.
4. Remove the decorative frame, and check frame top for discolouration and signs of spillage.
5. Disconnect the gas supply pipe, and remove the two securing screws in the tray legs.
6. Disconnect the three way plug from the solenoid to the control box and remove the burner tray.
7. Strip off the burner pipes and clean thoroughly.
8. Clean out the injector and pilot assembly. DO NOT damage pilot injector.
9. Remove the two securing screws and lift away control box heatshield.
10. Check electrical connection to the control box are sound, and earth screw is fully tightened.
11. Re-assemble and re-fit the burner tray, making sure to reconnect the three-way plug.
12. Re-fit the decorative front.
13. Re fit and replace the ceramics, using genuine spares where necessary.
14. Turn on the gas supply, and leak test.
15. Dismantle the fan terminal unit and clean thoroughly, especially the sensing pipes and fan blades.
16. Check the flue tube is free from obstruction and is correctly fitted.
17. Re-fit fan terminal, and reconnect the power supply
18. Check any purpose provided ventilation is un-obstructed.
19. Check fan for operation and electrical soundness.
20. Switch ON the fire and test for spillage.
21. Check setting pressure and safe operation of the appliance.

For specific servicing instructions, see the relevant sections.

13.1 CLEANING THE COALS

Remove the firefront casting and place to one side. Remove the ceramic components. Gently clean in the open air. Be careful not to create dust from the coals. Where necessary replace damaged components with genuine spares. Seal scrap components in plastic bags and dispose of at proper refuse sites as directed.

Re-fit the coals carefully by referring to the relevant section of these instructions.

13.2 DISMANTLING THE BURNER TRAY

Remove the tray as previously described. The pilot unit can be removed by undoing the tubing nut, the thermocouple nut on the rear of the valve, and the two securing screws, and lifting away. Remove the tubing nut from the valve end of the pilot pipe, and blow through to dislodge any debris. Clean the exterior of the pilot assembly with a soft brush and blow through the flame ports on the pilot head. Check the aeration holes are free from lint or dirt. The pilot assembly is a non-serviceable item, and should not be taken apart. The aeration hole must be absolutely clear internally for proper operation. A thoroughly cleaned (inside and out) oxypilot will cure a wide range of ignition faults. The injector can be removed from the base of the assembly with two spanners to make cleaning the aeration hole out easier. Remove the two tubing nuts on the ends of the gas pipe to the injector elbow. Release the screw through the supporting leg and lift assembly clear. The injector pipe can now be checked for debris. Remove the nut retaining the injector elbow. Blow through elbow to remove any debris.

The valve is not field serviceable, apart from the pilot filter. Remove the control knob by pulling it forwards, then remove the largest of the three screws on the face of the valve. Slide the filter out and clean away any debris that may have accumulated. The filter element should also be blown clean. This component should not require replacement, however if signs of deterioration are evident then a genuine spare must be used. If a large amount of debris is present in the filter then the pipework and control should be thoroughly cleaned before re-assembly.

13.3 CHECKING THE FAN ASSEMBLY

Disconnect the electrical supply, and remove the fan terminal cover. Check all components for signs of deterioration paying attention to the wiring, and ensuring all electrical connections are good.

Remove the terminal from the wall and check the flue tube is in the correct position. Check the flue is free from obstruction along its entire length. Clean outlet and airflow sensors with a suitable brush. Clean fan vanes and remove any debris. Refit the terminal to the wall. Ensure that no plants etc. obscure the exhaust outlet.

Reconnect the electrical supply and check the operation of the fan. Press the ON switch, the fan should build up speed with the warning light illuminated and then rest at normal operating speed. The light on the control box should extinguish. The safety solenoid on the burner tray should now open. Establish a pilot flame but **DO NOT** light the main burner. Block the fan outlet with a piece of card. The fan should build up speed in an effort to clear the 'obstruction', when this fails the pilot will be extinguished and the fan cut out. When you are sure the operation is correct, refit the terminal cover and wire cage.

13.4 CONTROL BOX REMOVAL

Disconnect the electrical supply and isolate the gas supply. Remove the burner tray as previously described in the relevant section. Remove the two securing screws and lift away the control box heatshield. Slide the control box to the left off its mounting bracket, and remove the multiway connector from the rear.

Replacement is reverse of removal, taking care to ensure the box is mounted securely and each individual connector pin makes good contact with the control box pin.

Schematic of appliance wiring

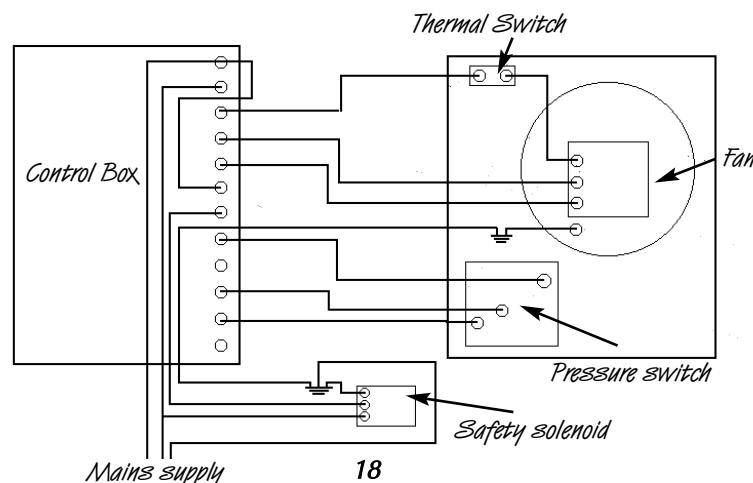

14.0 TROUBLESHOOTING GUIDE

Fan fails to start

Check wall switch is turned ON
Check the light on the control box illuminates when ON switch is pressed. If no light, check fuse.
Turn OFF the wall switch, check all plugs and connectors from fire to fan and fully and correctly fitted. If all connections are correct, suspect faulty wiring loom or control box.

Fan runs but cycles from high to low.

Check fan outlet for obstruction
Check all connections are fully and correctly fitted.
Ensure silicone sensing pipes and properly fitted to sensing tubes.
The terminal must only be fitted with the outlet facing downward.
This appliance is only for use with 230V~50Hz, being the standard UK domestic supply.

Fan cycles high to low on windy days

This is quite normal on windy days
If this occurs on still days then the pressure switch may be over sensitive. Consult the manufacturer before attempting any adjustment.
In exposed areas a small deflector plate may be fitted to the outlet to terminal guard cage the effects of prevailing winds.

Fan runs in correct sequence but will not pass spillage tests.

Check test conforms to manufacturers instructions
Check for blockages or leaks in flue or fan outlet.
Check gas type and pressure are correct for appliance.
Check for adequate ventilation or the effect of extractor fans.

Fan runs but pilot flame will not hold when control knob is released

Loose thermocouple connection in rear of gas valve
Check pilot flame is engulfing tip of thermocouple.

Pilot will not light

Check gas is turned ON and all pipes are purged of air.
Check for spark between pilot body and electrode. Check spark gap is correct to specification. Check the HT lead is connected to pilot body.
Check gas line and filters for blockages.
Check to see if pilot can be lit with match or taper whilst depressing control knob.
Safety solenoid may not be opening. Listen for click after starting fan.

Pilot shrinks when fire is turned to high

Sign of insufficient gas pressure causing pilot starvation. Check appliance pressure at test point.
Ensure restrictor elbow is fully open.
Suspect undersized or partially blocked supply pipes.
Check none of the fittings are causing restriction. Excess solder and flux can obstruct pipes.

Fan or fire cuts off when getting hot

Check for blockages in flue outlet which could cause thermal trip to operate.
Check for pilot shrinkage due to low gas pressure.

Fan constantly runs at high speed.

Check connection from wiring loom to pressure switch are fitted correctly.
Under normal conditions the fan should only run for a few moments at high speed before the pressure switch detects airflow, dropping the fan down to normal speed.
Consult the manufacturers before attempting any adjustment of the pressure switch

USER INSTRUCTIONS

<i>Section</i>	<i>Contents</i>	<i>Page No.</i>
1.0	Important Notes	1
2.0	Firefront	2
3.0	Clearances to Combustibles	2
4.0	Ventilation	2
5.0	Operating Instructions	2
6.0	Flue Spillage Monitoring System	3
7.0	Cleaning	3
8.0	List of Spares	3

1.0 IMPORTANT NOTES

The installation of this fire **MUST** only be carried out by a competent person (such as a CORGI registered fitter) in accordance with the Gas Safety (Installation and Use) Regulations 1998, the relevant British Standards, Codes of Practice, the Building Regulations and the manufacturers' instructions.

Failure to comply with the above recommendations could lead to prosecution and invalidate the appliance warranty.

Please ensure you are handed all of the manufacturers documents on completion of the installation. This will include these instructions.

Always keep a note of the installer's name and address, the original purchase receipt and the date of installation for future reference.

The fire and flue should be serviced regularly to ensure continued safe operation. See the servicing section for further details. Frequency of service will depend on use, but **MUST** be carried out at least once annually.

Parts of this appliance become naturally hot during use. It is recommended that a suitable fire guard conforming to BS 6778 is used, especially where young children, the elderly, or infirm are concerned.

Combustible items, such as flooring and furniture, and soft wall coverings (such as blown vinyl or embossed paper) may discolour if fitted too close to the fire. See relevant section for further details on clearances to combustibles. No combustible material or flooring should protrude onto the hearth.

DO NOT burn any foreign material on this fire, the coals must be of the correct type and laid out in accordance with the relevant section of these instructions. Failure to do so could create a hazard or lead to sooting.

Before the appliance is installed, the chimney should be swept. All flues should be checked by the installer to ensure there are no defects or obstructions that may prevent the flow of combustion products.

This appliance is fitted with a flue blockage safety device which will shut down the fire if abnormal flue conditions occur. It is **NOT** a substitute for an independently mounted Carbon Monoxide detector.

The fire is only suitable for use with the gas type for which it is supplied.

2.0 FIREFRONT

This fire is supplied with a particular style of firefront. Use of the firefront will ensure an adequate airflow under the firebed for the correct functioning of this appliance.

Compliance with safety standards cannot be guaranteed if another style of front is used.

3.0 CLEARANCES TO COMBUSTIBLES

A combustible shelf may be fixed to the wall above the fire, providing that it complies with the dimensions given below.

<i>Maximum depth of shelf</i>	<i>Minimum distance from inside edge of fire frame to underside of shelf</i>
100mm (4in)	203mm (8in)
150mm (6in)	305mm (12in)
203mm (8in)	356mm (14in)

A non-combustible shelf may be fitted to within 10mm of the top edge of the fireframe.

Combustible materials, such as wood, may be fitted to within 100mm (4in) of either side of the frame of the appliance, providing the forward projection does not exceed 100mm (4in).

Any combustible side walls must be at least 500mm to the side of the radiant heat source.

As with all heating appliances, any decorations, soft furnishings, and wall coverings (i.e. flock, blown vinyl and embossed paper) positioned too close to the appliance may discolour or scorch.

4.0 VENTILATION

No purpose provided ventilation is normally required for this appliance. The requirements of other appliances operating in the same space or room, and the results of a spillage test must be taken into consideration when assessing ventilation requirements, this will have been carried out by your CORGI registered installer.

For Republic of Ireland, ventilation may be required, see IS 813, ICP3, IS 327, and any other rules in force.

5.0 OPERATING INSTRUCTIONS

Turn on the power supply and momentarily press the ON switch on the control box. The fan should operate with the warning light illuminated. After a very short time the fan will run at normal speed and a click may be heard as the safety solenoid opens. The warning light should extinguish.

The pilot is visible through the left hand coal. Rearrange for good viewing if necessary. Push in and turn the control knob to the SPARK position, and hold there for a few seconds. Continue turning anti-clockwise through the spark click to the PILOT light position, ensuring the pilot has lit. If not, return the knob clockwise, and repeat.

When the pilot lights after the spark, keep the knob depressed for approximately ten seconds. Now release the knob and the pilot should stay alight. If not, repeat ignition. If the pilot is extinguished **during use**, wait three minutes before repeating the ignition procedure. To achieve the HIGH setting, push the control knob in slightly and continue turning anti-clockwise to the high position. The main burner should light after a few seconds. To decrease the setting to LOW, turn the control knob clockwise to the low setting. To turn to the PILOT position from the HIGH or LOW positions, press the control knob in, and return to the pilot position and release.

To turn the fire OFF, keep the knob pressed in, return to the off position and release. Press the OFF button on the control box to switch off the fan.

6.0 FLUE SPILLAGE MONITORING SYSTEM

This fire is fitted with a flue spillage safety device (ODS). If the fire shuts down during use for no apparent reason then several reasons may be suspected. If a door or window has been opened creating a draught, then pilot disturbance could be the problem, and removal of the draught should resolve this. The fire can then be re-lit in accordance with the previous section. A sealing grommet may have been omitted when the fire was installed, and the original installer should be called to check this, the gas pressure and pipework.

If pilot disturbance is not the cause, then the ODS safety system may be in operation. Switch the appliance OFF, call in your installer to check the flue and ventilation and carry out any remedial work required. DO NOT allow the appliance to be used until the flue system is passed as safe.

7.0 CLEANING

Before carrying out any of the following operations, ensure that the fire is OFF and completely cold.

Debris that may form on the firebed should be periodically removed by a competent person. Large deposits could indicate deterioration of the flue. This should be repaired by a competent person, and the fire serviced before further use.

FIREFRAME (Ashleigh Plus) - This is retained by one of two methods, either by magnetic backing pieces, or a three piece clip-on assembly. The magnetic frame may be removed for cleaning if required, however the clip-on style must not be removed. A wipe with a dry cloth is normally sufficient, but on stains it is permissible to use a damp cloth with a mild household cleaner, followed by a wipe with a dry cloth. DO NOT use abrasive cleaners as these may damage the finish. To re-assemble ensure the magnets are placed on the steel backing pieces, and re-fit to the firebox.

CAST FIREFRONT - Any dust accumulating in the firefront may be removed using a vacuum cleaner or dry cloth. Heavy stains may be removed by using a damp cloth and mild household detergent. Brass parts of the firefront may be cleaned using a suitable brass cleaner. Replace the front centrally against the fire after cleaning.

PAINTED AREAS - These can be cleaned using a dry cloth.

COALS AND CERAMICS - See the relevant section in the Installation Guide of these instructions. Do not create dust from the coals. Clean gently in the open air. Replace components with original spares only as necessary.

8.0 LIST OF SPARES

<i>PART NO.</i>	<i>ITEM</i>
FT003033/0	Pack of 15 coals
FB004050/0	Briquette backpanel
FT003005/0	Ceramic combustion matrix
FB004030/0	Ceramic Side Cheeks
Enquire	Decorative Frame
Enquire	Decorative Front