

**FOCAL
POINT
FIRES** plc

ΣENIGMA

Fuel Effect Gas Fire

INSTALLATION, SERVICING AND USER INSTRUCTIONS

All instructions must be handed to the user for safekeeping

Revision A 09/03

Country(s) of destination: GB, IE

Focal Point Fires plc, Avon Trading Park, Christchurch, Dorset BH23 2BT

☎: (01202) 499330

Fax: (01202) 499326

www.focalpointfires.co.uk

e-mail: sales@focalpointfires.co.uk



Patent applied for

7.0 CLEANING (continued)

GLASS CRYSTALS - If necessary, the glass crystals may be removed from the firebowl and cleaned in lukewarm mild soapy water. Rinse thoroughly in clean water and ensure the glass is completely dry before refilling. **Important - Wear protective gloves when handling the glass crystals.**

CERAMAT - Any debris or dust that has accumulated on the mat may be carefully removed with a vacuum cleaner. DO NOT use sharp objects or tools to clean the mat as this may damage the mat.

8.0 LIST OF SPARES

<i>PART NO.</i>	<i>ITEM</i>
CE/F550071	Pack of 10 individual Ceramic Pebbles (Glass/pebble models only)
CE/F920006	Pack of heat resistant Glass Crystals (Glass/pebble models only)
CE/F770006	Replacement Ceramat Mat (Ceramat models only)
CE/F830015	Replacement Clamping Ring (Ceramat models only)
FT/F730006	ODS pilot unit
FT/F730020	Main burner injector
FT/F730015	BM 733 valve (special)
FT/F870009	Control Knob
FT/F830016	Decorative Foot

5.0 FUEL BED LAYOUT (Glass/pebble models) - continued

2. Open the bag of 10 ceramic pebbles. All of these pebbles are the same size, but may vary slightly in shape in order to create a natural effect. Take six pebbles and place them as shown, in the centre of the burner.

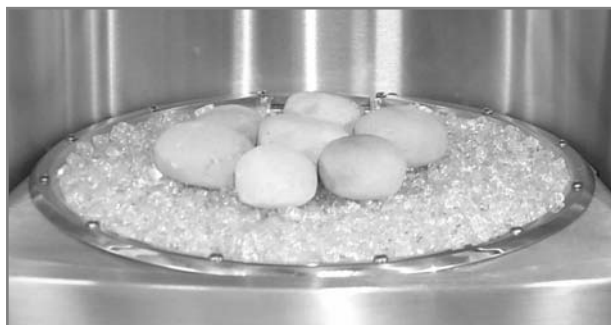

3. Take four more pebbles and place them as shown, on top of the first six pebbles



The fire is designed to operate correctly with the pebbles supplied when assembled according to the instructions. Never add to the ten pebbles, or change them for a different type. Never throw rubbish or other matter onto the fuel bed.

Due to the light colour of the pebbles, some discolouration/sooting is to be expected during normal use.

5.1 FUEL BED LAYOUT (Cerammat models)

The Ceramat fuel bed is supplied ready for use, and no set up is required. The Mat itself is a high performance burner medium of ceramic fibres which are welded together with silicon carbide in order to create a rigid mat structure. The individual fibres of the mat can be seen to randomly illuminate when the appliance is used on lower settings. The mat is fragile - if for any reason it is necessary to touch the mat, great care should be taken.

6.0 FLUE SPILLAGE MONITORING SYSTEM

This fire is fitted with a flue spillage safety device (ODS). If the fire shuts down during use for no apparent reason then several reasons may be suspected. If a door or window has been opened creating a draught, then pilot disturbance could be the problem, and removal of the draught should resolve this. The fire can then be re-lit in accordance with the previous section.

If pilot disturbance is not the cause, then the ODS safety system may be in operation. Switch the appliance OFF, call in your installer to check the flue and ventilation and carry out any remedial work required. DO NOT allow the appliance to be used until the flue system is passed as safe.

7.0 CLEANING

Before carrying out any of the following operations, ensure that the fire is OFF and completely cold. Debris that may form on the firebed should be periodically removed by a competent person. Large deposits could indicate deterioration of the flue. This should be repaired by a competent person, and the fire serviced before further use.

PAINTED AREAS - These can be cleaned using a dry cloth.

CERAMICS - See the relevant section in the Installation Guide of these instructions. Do not create dust from the ceramics. Clean gently in the open air. Replace components with original spares only as necessary.

STAINLESS STEEL AREAS - These areas may be cleaned using a soft damp cloth or stainless steel cleaner.

IMPORTANT - Always clean in the direction of the grain, and never across it as this will scratch the surface. It is recommended that a small area is attempted before cleaning the entire stainless steel area - to ensure the cleaning material is suitable.

2.0 CLEARANCES TO COMBUSTIBLES (continued)

A non-combustible shelf may be fitted to within 10mm of the top edge of the fireframe.

Combustible materials, such as wood, may be fitted to within 100mm (4in) of either side of the frame of the appliance, providing the forward projection does not exceed 100mm (4in). Any combustible side walls must be at least 500mm to the side of the radiant heat source. As with all heating appliances, any decorations, soft furnishings, and wall coverings (i.e. flock, blown vinyl and embossed paper) positioned too close to the appliance may discolour or scorch.

3.0 VENTILATION

IMPORTANT : For Republic of Ireland ventilation may be required, see IS 813, ICP3, IS 327, and any other rules in force.

NV Models : No purpose provided ventilation is normally required for this appliance. The requirements of other appliances operating in the same space or room, and the results of a spillage test must be taken into consideration when assessing ventilation requirements, this will have been carried out by your CORGI registered installer.

PLUS Models : 15cm² of purpose provided ventilation is required for this appliance. This must comply with BS 5871 part 2 and BS 5440 part 2. The requirements of other appliances operating in the same space or room, and the results of a spillage test must be taken into consideration when assessing ventilation requirements, this will have been carried out by your CORGI registered installer.

4.0 OPERATING THE FIRE

The control knob of the fire is marked as follows ;

The pilot is visible at the rear of the burner. Push in and turn the control knob to the SPARK position, and hold there for a few seconds.



'OFF' position

Continue turning anti-clockwise through the spark click, ensuring the pilot has lit. If not, return the knob clockwise, and repeat.



'SPARK' position

When the pilot lights after the spark, keep the knob depressed for approximately ten seconds. Now release the knob and the pilot should stay alight. If not, retry ignition. If the pilot is extinguished during use, wait three minutes before repeating the ignition procedure.



'LOW' position

To achieve the HIGH setting, push the control knob in slightly and continue turning anti-clockwise to the large flame position. The main burner should light after a few seconds.



'HIGH' position

To decrease the setting to LOW, turn the control knob clockwise to the low flame setting. The flame height may be adjusted as desired between high and low settings by turning the control knob to the

required position between 'HIGH' and 'LOW'. To turn to the PILOT position from the HIGH or LOW positions, press the control knob in, and return to the pilot position and release.

To turn the fire OFF, keep the knob pressed in, return to the off position and release.

5.0 FUEL BED LAYOUT (Glass/pebble models)

Important : Wear protective gloves when handling the glass crystals.

1. Fill the burner with glass crystals as shown. The crystals should be spread evenly and level up to the same level as the edge of the burner.



USER INSTRUCTIONS

<i>Section</i>	<i>Contents</i>	<i>Page No.</i>
1.0	Important Notes	1
2.0	Clearances to Combustibles	2
3.0	Ventilation	2
4.0	Operating The Fire	2
5.0	Fuel Bed Layout	3
6.0	Flue Spillage Monitoring System	3
7.0	Cleaning	3
8.0	List of Spares	4

1.0 IMPORTANT NOTES

The installation of this fire **MUST** only be carried out by a competent person (such as a CORGI registered fitter) in accordance with the Gas Safety (Installation and Use) Regulations 1998, the relevant British Standards, Codes of Practice, the Building Regulations and the manufacturers' instructions.

Failure to comply with the above recommendations could lead to prosecution and invalidate the appliance warranty.

Please ensure you are handed all of the manufacturers documents on completion of the installation. This will include these instructions.

Always keep a note of the installer's name and address, the original purchase receipt and the date of installation for future reference.

The fire and flue should be serviced regularly to ensure continued safe operation. See the servicing section for further details. Frequency of service will depend on use, but **MUST** be carried out at least once annually.

Parts of this appliance become naturally hot during use. It is recommended that a suitable fire guard conforming to BS 6778 is used, especially where young children, the elderly, or infirm are concerned.

The appliance requires a hearth with non-combustible surface of at least 12mm thick. The top surface must be at least 50mm above the surrounding floor level, or be surrounded by a raised edge or fender 50mm high. The hearth must protrude 325mm in front of the fireplace opening and extend at least 150mm on each side of the incandescent area.

Combustible items, such as flooring and furniture, and soft wall coverings (such as blown vinyl or embossed paper) may discolour if fitted too close to the fire. See relevant section for further details on clearances to combustibles. No combustible material or flooring should protrude onto the hearth.

DO NOT burn any foreign material on this fire, the fuel effect must be of the correct type and laid out in accordance with the relevant section of these instructions. Failure to do so could create a hazard or lead to sooting. Before the appliance is installed, the chimney should be swept. All flues should be checked by the installer to ensure there are no defects or obstructions that may prevent the flow of combustion products. This appliance is fitted with a flue blockage safety device which will shut down the fire if abnormal flue conditions occur. It is **NOT** a substitute for an independently mounted Carbon Monoxide detector. The fire is only suitable for use with the gas type for which it is supplied.

2.0 CLEARANCES TO COMBUSTIBLES

A combustible shelf may be fixed to the wall above the fire, providing that it complies with the dimensions given below.

<i>Maximum depth of shelf</i>	<i>Minimum distance from finished hearth surface to underside of shelf</i>
100mm (4in)	790mm (31 in)
150mm (6in)	890mm (35 in)
200mm (8in)	990mm (39 in)

15.5 REMOVING THE FIREBOX

Remove the burner unit as previously described. Uncoil the fixing kit cables from the rear of the firebox, remove the screwed nipples and tensioning adjusters. The firebox can now be withdrawn from the opening and outwards onto the protected hearth.

Inspect the fireplace opening for debris, and if excessive rectify the flue before proceeding further. Check the seal around the fireframe and replace if necessary. Refitting of the firebox is described in the relevant section.

16.0 TROUBLESHOOTING GUIDE

Fire sparks but pilot does not light

No gas to fire, check isolators are open.
Pipework blockage, clean out.
Air not fully purged, repurge supply or wait longer.
Spark earthing to metal work, reset gap correctly.
Blocked pilot, clean out internally.

Pilot lights but then goes out

Severe restriction in gas supply, clear obstruction.
Faulty thermocouple, replace pilot unit.
Hold control knob in for longer.
Check control spindle does not foul front panel of firebowl.

Fire does not spark at pilot

HT lead detached, refit.
Spark gap too large or small, reset correctly.
Faulty piezo unit, replace.
Debris shorting out electrode, clean.

Fire runs for a time and then cuts off

Excessive room draught or flue pull, rectify.
Loose or faulty thermocouple, rectify.
ODS system in operation.
Firebox grommet seal not fitted, rectify.
Lint in pilot aeration hole, clean thoroughly internally.

Pilot flame shrinks when fire is on high

Poor gas flow to fire, check pressure with fire on high.
If pressure is low, remove any restriction in pipework or valve.
Check all isolators are adequately sized and fully open.
Check meter pressure is adequate.
Air leak under base of firebox, rectify.
Lint in pilot aeration hole, clean thoroughly internally.

Fire smells when first lit or in use

Newness smell from brand new appliance.
Spillage occurring. Carry out spillage test and rectify any problems.
Low temperature sealants or combustible materials used in incorrect position.
Air leak under base of firebox, rectify.

15.0 SERVICING (continued)

15. Turn on the gas supply, and leak test.
16. Re fit the front panel of the fire, and the control knob.
17. Check any purpose provided ventilation is un-obstructed.
18. Light the fire and test for spillage.
19. Check setting pressure and safe operation of the appliance.

For specific servicing instructions, see the relevant sections.

15.1 CLEANING THE CERAMICS (Glass/pebble models)

WARNING: The glass crystals remain hot for a considerable time after the appliance has been turned off. It is recommended that the appliance be left to cool for at least two hours before any part of the fuel bed is removed for cleaning. **Wear protective gloves when handling the glass crystals.**

Remove the ceramic components. Gently clean in the open air. Be careful not to create dust from the pebbles. Where necessary replace damaged components with genuine spares. Seal scrap components in plastic bags and dispose of at proper refuse sites as directed.

Re-fit the pebbles carefully by referring to the relevant section of these instructions.

If necessary, the glass crystals may be removed from the firebowl and cleaned in lukewarm mild soapy water. Rinse thoroughly in clean water and ensure the glass is completely dry before refilling.

15.2 CLEANING THE CERAMAT

Any debris or dust that has accumulated on the mat may be carefully removed with a vacuum cleaner. **DO NOT** use sharp objects or tools to clean the mat as this may damage the mat.

15.3 CLEANING THE FIREBOX

Stainless steel parts of the fire may be cleaned using a soft damp cloth or stainless steel cleaner.

IMPORTANT: Always clean in the direction of the grain, and never across it as this will scratch the surface. It is recommended that a small area is attempted before cleaning the entire stainless steel area - to ensure the cleaning material is suitable.

15.4 DISMANTLING THE BURNER UNIT

Remove the burner unit as previously described. The pilot unit can be removed by undoing the tubing nut, the thermocouple nut on the rear of the valve, lint arrestor, two securing screws, and lifting away. Remove the tubing nut from the valve end of the pilot pipe, and blow through to dislodge any debris that may be present. Clean the exterior of the pilot assembly with a soft brush and blow through the flame ports on the pilot head. Check the aeration holes are free from lint or dirt. The pilot assembly is a non-serviceable item, and should not be taken apart. The aeration hole must be absolutely clear internally for proper operation. A thoroughly cleaned (inside and out) oxy-pilot will cure a wide range of ignition faults. The injector pipe can now be checked for debris. Remove the two tubing nuts on the ends of the gas pipe to the injector elbow. The injector pipe can now be checked for debris. Remove the air shutter from the injector bracket by removing two screws. Remove the nut retaining the injector elbow. Blow through the elbow to remove any debris.

The valve is not field serviceable, apart from the pilot filter. Remove the largest of the three screws on the face of the valve. Slide the filter out and clean away any debris that may have accumulated. The filter element should also be blown clean. This component should not require replacement, however if signs of deterioration are evident then a genuine spare must be used. If a large amount of debris is present in the filter then the pipework and control should be thoroughly cleaned before re-assembly.

14.5 TESTING FOR SPILLAGE (continued)

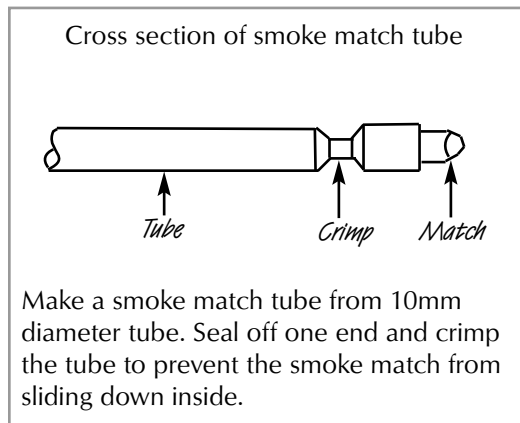

A. 25mm down from top of opening
B. 25mm in from front of opening.
C. Disregard outer 50mm either side of fireplace opening

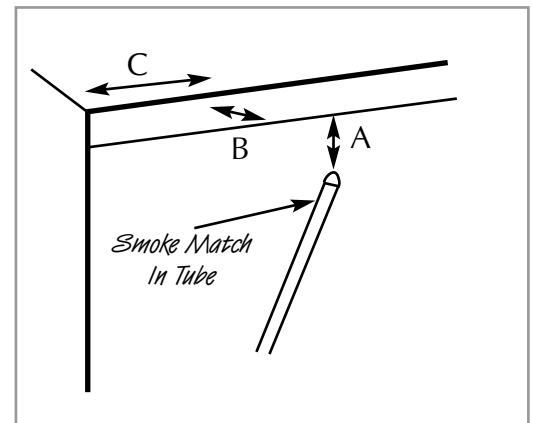

NOTE: If spillage is still indicated after undertaking all of the above, there may be a fault in the flue, or insufficient ventilation is present.

If the problem cannot be rectified immediately, then expert advice should be sought. Inform the user, disconnect the fire, and attach an explanatory label.

14.6 BRIEFING THE CUSTOMER

All instructions must be handed to the user for safekeeping. **Show the customer how to light and control the fire.**

After commissioning the appliance, the customer should be instructed on the safe use of the appliance and the need for regular servicing. Frequency of service depends on usage, but MUST be carried out at least once annually.

The stainless steel bowl may be cleaned using a soft damp cloth or stainless steel cleaner.

IMPORTANT - Always clean in the direction of the grain, and never across it as this will scratch the surface. It is recommended that a small area is attempted before cleaning the entire stainless steel area - to ensure the cleaning material is suitable.

Pebble Models : DO NOT attempt to spray paint the pebbles, or wash them in water.

15.0 SERVICING

Ensure that the fire is fully cold before attempting service. A suggested procedure for servicing is detailed below.

1. Lay out the dust sheet and tools.
2. Carefully remove the control knob, and front panel of the fire, and ceramic components (where applicable).
3. Remove the decorative frame, and check frame top for discolouration and signs of spillage.
4. Remove the control knob and remove the front panel of the appliance.
5. Isolate the gas supply at the appliance inlet elbow, and disconnect the gas supply pipe. Remove the four screws securing the burner to the firebox.
6. Lift the burner tray from firebox.
7. Remove the firebox as detailed in the relevant section.
8. Check the area behind the firebox for rubble accumulation and remove. If debris is excessive, initiate remedial work on the flue.
9. Check the flue with smoke pellet for correct operation.
10. Re-fit the firebox using new seals where necessary.
11. Strip off the burner pipes and clean thoroughly.
12. Clean out the injector and pilot assembly. DO NOT attempt to dismantle the pilot unit.
13. Ensure the injector is aligned squarely with the venturi tube. Re-assemble and re-fit the burner unit.
14. Re fit and replace the glass crystals and ceramics where applicable, using genuine spares where necessary.

14.2 OPERATING THE FIRE

The control knob of the fire is marked as follows ;

The pilot is visible at the rear of the burner. Push in and turn the control knob to the SPARK position, and hold there for a few seconds.

 'OFF' position

 'SPARK' position

 'LOW' position

 'HIGH' position

Continue turning anti-clockwise through the spark click, ensuring the pilot has lit. If not, return the knob clockwise, and repeat.

When the pilot lights after the spark, keep the knob depressed for approximately ten seconds. Now release the knob and the pilot should stay alight. If not, retry ignition. If the pilot is extinguished during use, wait three minutes before repeating the ignition procedure.

To achieve the HIGH setting, push the control knob in slightly and continue turning anti-clockwise to the large flame position. The main burner should light after a few seconds.

To decrease the setting to LOW, turn the control knob clockwise to the low flame setting. The flame height may be adjusted as desired between high and low settings by turning the control knob to the required position between 'HIGH' and 'LOW'.

To turn to the PILOT position from the HIGH or LOW positions, press the control knob in, and return to the pilot position and release.

To turn the fire OFF, keep the knob pressed in, return to the off position and release.

14.3 SPARK FAILURE

The gap between the spark electrode and the pilot should be 3.5 - 4.5mm to produce a good spark. There should be no need to adjust this. If under any circumstances the electric spark fails, the pilot may be lit manually by proceeding with the ignition sequence as previously described, and after turning the control knob through the spark position, the knob should be held in and the pilot lit with a taper.

14.4 FLUE SPILLAGE MONITORING SYSTEM

This fire is fitted with a flue spillage safety device (ODS). If the fire shuts down during use for no apparent reason then several things may be suspected. If a door or window has been opened creating a draught, then pilot disturbance is the problem, and removal of the draught should resolve this. The gas pressure reaching the fire must also be checked. The thermocouple connection into the back of the gas control valve may also have worked loose during installation, simply tighten to remedy if this is the case.

If pilot disturbance is not the cause, then the ODS safety system may be in operation. Switch the appliance OFF, check the flue and carry out any remedial work required. Relight the fire and carry out a spillage test. DO NOT allow the appliance to be used if it continues to fail a spillage test. The aeration hole of the pilot must be carefully cleaned out on each annual service to ensure continued function of the ODS.

The spillage monitoring system shall not be adjusted, modified, or put out of operation by the installer. Any spare parts fitted MUST be of a type supplied for the purpose by the appliance manufacturer.

If the fire is not spilling, then further guidance should be sought, using the Troubleshooting section as a guide.

14.5 TESTING FOR SPILLAGE

Close all doors and windows to the room containing the appliance. Let the fire run on HIGH for five minutes. Take a smoke match, light it, and using a smoke match tube, hold it at the top edge of the fire opening, 25mm down and 25mm in. Starting 50mm in from either side, run the smoke match across the opening. All the smoke should be drawn away up the flue. Any smoke returning into the room indicates that spillage is occurring. If the initial spillage test fails, run the fire for a further 10 minutes and repeat the test. When the test has been completed satisfactorily, repeat with any extractor fans in the premises running on the highest setting, and any communicating doors open. Finally, repeat with all doors open.

12.0 FUEL BED LAYOUT

Please refer to the relevant section of the user manual section of this booklet.

13.0 FITTING THE DECORATIVE FRAME

The appliance is supplied with a decorative frame in a variety of finishes. The frame is held onto the firebox by four magnets. Ensure the magnets are aligned onto the magnet plates in each corner of the firebox.

14.0 TESTING AND COMMISSIONING

Turn on and test the gas supply up to the fire for any leaks, in accordance with current Approved Codes Of Practice (ACOPs).

14.1 SETTING PRESSURE

With the front panel of the fire removed, temporarily re-connect the control knob to the control spindle. To light the fire, follow the instructions given in section 14.2, bearing in mind that when the front panel of the firebox is in position the indicator pip would be at twelve o'clock in relation to the control knob.

Remove the screw from the pressure test point, situated on the main injector pipe to the left hand side of the valve, and attach a U gauge. Light the fire on the HIGH setting.

The setting pressure should be in accordance with the figures stated on page 2 of these instructions. The fire is factory set to achieve these pressures, and any significant variation could indicate a supply problem. If the pressure is too high, the gas supply meter may be set incorrectly. This should be checked with the fire running and if necessary reset by the gas supplier.

If the pressure is too low, then check the meter governor pressure with the appliance running. If this is incorrect it will need to be reset by the gas supplier. If the setting pressure is too low, but the meter pressure is acceptable, then a problem in the supply pipework is to be suspected. This will be dirt and debris, kinked or inadequate size pipes, restriction in a fitting or solder flashing across a joint. (NOTE: you will not get an accurate reading of the inlet pressure with a pressure gauge on the end of the supply pipe - this is the static pressure in the system. You must use a T piece and measure the supply pressure with the fire on High - the dynamic pressure). Refit and tighten the screw into the pressure test point when the test is complete.

Refit the front panel of the appliance and secure the control knob to the spindle using the grub screw provided. Ensure the control markings on the knob line up correctly with the indicator pip on the front panel as detailed in section 12.1 of these instructions.

When the appliance is first used, protective oils coating the firebox may burn off. It is advisable to ventilate the room during this period.

10.0 GAS SUPPLY ROUTING

Following preparation for the fixing method, the concealed gas supply, where required, can now be put into place.

IMPORTANT - Wherever a concealed connection is made a rubber grommet must be used to seal the firebox.

The gas pipe must be suitably protected where it passes through fireplace openings. Any sleeving should be sealed to the pipe at its ends. This appliance is fitted with an inlet restrictor elbow. The elbow is located to the right of the gas valve.

The open end of the 8mm supply pipe should be sealed temporarily during the installation of the firebox to prevent the ingress of dirt and dust during fixing.

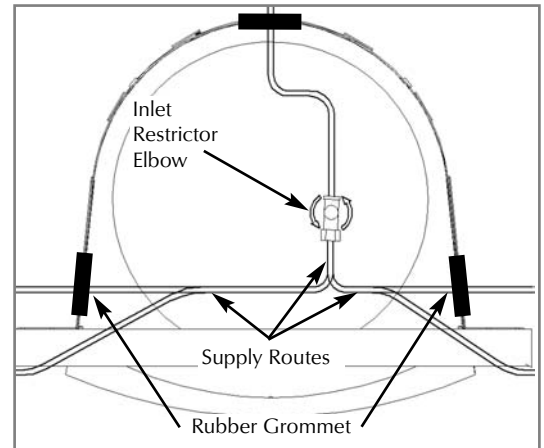

11.0 FITTING THE FIREBOX

The firebox may be fitted to the opening by using screw fixing or by the cable kit as described in the relevant section. Leave the polythene coating in place until fitting procedures are complete to eliminate any risk of scratching the decorative finish. Fit the firebox, ensuring the fire sits fully back in the opening.

11.1 CABLE FIXING

Drill four holes as shown in the diagram and fit the fibre rawl plugs. If the fireplace does not allow for the exact layout shown, the eyebolts should be fixed to give a similar configuration as possible.

Thread both tensioning cables through the holes at the top of the firebox (inset), both eyelets, and back through the lower holes in the firebox as shown.

Before finally fitting the firebox, ensure the self-adhesive sealing strips are in position around the rear of the firebox frame.

Push the appliance back into the fireplace, centralise and pull the loose cables through the holes into the firebox. Thread the cable tensioners onto the cables as shown, with the nuts screwed down close to the tensioner head.

Slide the screwed nipple onto the cable, pull cable taut and tighten nipple. Adjust tensioner using a suitable spanner to pull the appliance back into position, to allow an even seal around the fireplace opening. Visually inspect the seal and reseal if necessary.

Surplus tension cable **MUST NOT** be cut off as this will prevent proper installation after servicing. Coil up the surplus cable and store in the rear of the firebox.



11.2 GAS CONNECTION

Refit the burner unit into the firebox, fit the four screws through the locating holes in the rim of the burner, and tighten. Purge the gas supply thoroughly to remove air and dirt/debris **BEFORE** connection. Now disconnect the inlet restrictor elbow from the inlet pipe.

Connect the previously installed gas supply to inlet restrictor elbow, and re-fit the restrictor elbow to the inlet pipe of the appliance.

If using an across hearth connection, ensure the decorative fire-frame and front panel will clear the supply route.

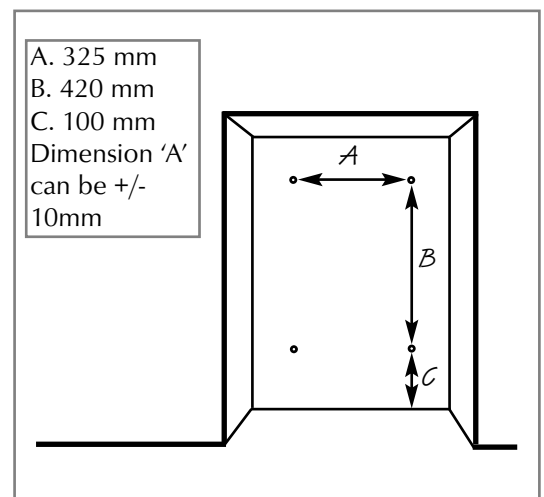

8.0 PREPARING THE APPLIANCE

Note: Ensure that the gas supply is isolated before commencing installation of the appliance.

The fireplace opening and environment must be in compliance with the specifications laid down in the appropriate sections of these instructions.

Remove the appliance from its carton as described previously and stand upon a dust sheet or similar. Place the decorative frame, ceramics (if applicable) and fixings safely to one side. The burner unit may be removed from the stainless steel firebowl by removing the four screws shown. An allen key is provided for this purpose.



It is also necessary to remove the control knob. This is achieved by removing the grub screw at the rear of the knob. With the knob removed, the front panel of the appliance may be lifted off to allow access to the gas valve, pressure test nipple and appliance inlet.

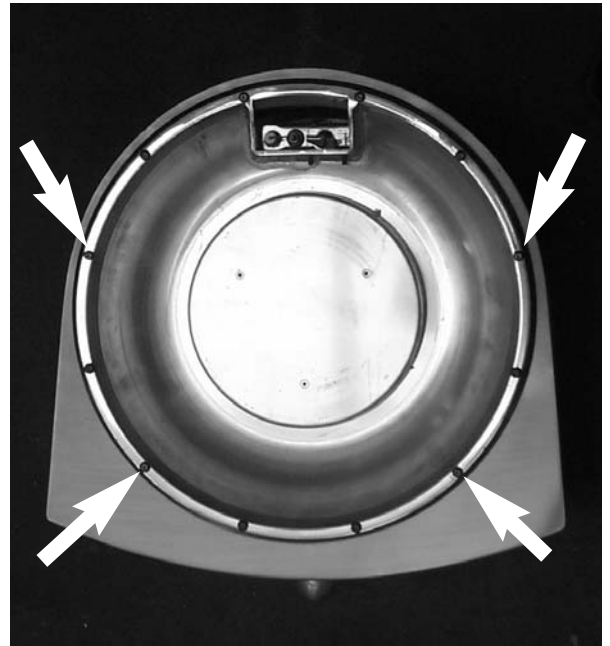

Knockout holes are provided in the sides and rear of the firebox for use where concealed pipework is required. Where necessary, knock out the appropriate hole with a sharp tap from a hammer, and fit the rubber grommet supplied. A small incision can now be made in the rubber to slip snugly around the outside of the pipe and sleeving. **Do not install or use the appliance without the seals in place.** If a hole is inadvertently opened, reseal with an intact grommet. Failure to fit the seal correctly will cause flue suction to act upon the area under the burner, resulting in poor performance and possible intermittent cutting out of the burner.

9.0 PREPARING THE OPENING

Before installing the fire, check the flue using a smoke pellet. All of the smoke should travel up the flue and exit correctly from the terminal. If problems are found, DO NOT fit the fire until corrective action is completed.

Protect the hearth surface whilst pushing the firebox in and out of the opening. Part of the packaging makes an ideal hearth saver pad. Before running the gas supply into the opening, offer up the firebox to the fireplace to check the fit is good. Ensure that it slides in correctly, the sealing face sits flat and square to the wall or infill panel, and that the base is firm on the floor of the opening as no leaks are permissible here. At this stage it is essential to ensure that the spigot outlet of the fire is not restricted in any way. Remove the firebox and take any necessary measurements before making good and preparing for final installation. Apply the self adhesive sealing strips around the edge of the rear of the firebox frame, approximately 5mm in from the edge.

CABLE FIXING. For fixing of the fire by the cable method, see the relevant section. The cable fixing locations should be marked on the back of the opening and the holes drilled. Fit the fibre rawlplugs and eyebolts to these holes. **Note: Plastic rawlplugs are NOT suitable for this application.**

SCREW FIXING. For fixing by screw, mark and drill the fireframe or base, and the relevant points in the opening or on the wall. Rawlplugs will again be required. Pre-punched holes are not provided for this purpose to allow you to choose the optimum positions.

5.0 VENTILATION

IMPORTANT : For Republic of Ireland ventilation may be required, see IS 813, ICP3, IS 327, and any other rules in force.

NV Models : No purpose provided ventilation is normally required for this appliance. The requirements of other appliances operating in the same room or space must be taken into consideration when assessing ventilation. If spillage is detected when commissioning the appliance then amongst other problems there may be insufficient natural ventilation for the correct operation of the flue. This is potentially a greater problem should the property be of modern nature. If the appliance does not spill with windows open but does with windows closed, this proves that lack of ventilation is the problem, if not, it will be the flue at fault. Installation of an air brick is the best solution. Any ventilation fitted must comply with BS 5871 part 2 and BS 5440 part 2.

Ventilation located underneath or within the immediate vicinity of the fire **MUST NOT** be used as it may adversely affect the performance of the O.D.S. system. Spillage detected during commissioning is almost always a result of poor flue performance, which cannot be corrected by any amount of ventilation.

PLUS Models : 15cm² of purpose provided ventilation is required for this appliance, which must comply with BS 5871 part 2 and BS 5440 part 2. Ventilation located underneath or within the immediate vicinity of the fire **MUST NOT** be used as it may adversely affect the performance of the O.D.S. system. If spillage is detected when commissioning the appliance then amongst other problems there may be insufficient natural ventilation for the correct operation of the flue. This is potentially a greater problem should the property be of modern nature. If the appliance does not spill with windows open but does with windows closed, this proves that lack of ventilation is the problem, if not, it will be the flue at fault. Installation of a larger air brick is the best solution.

Spillage detected during commissioning is almost always a result of poor flue performance, which cannot be corrected by any amount of ventilation.

6.0 UNPACKING THE APPLIANCE

Stand the carton right way up, cut the strapping bands and remove the top end cap. Read all the instructions before continuing to unpack or install this appliance.

Remove the packing pieces, and any bags containing other fittings or parts. When all loose parts have been removed, the outer sleeve may be lifted off to reveal the appliance. Check that the components supplied correlate with the checklist given in section 7.1. Please dispose of the packaging materials at your local recycling centre.

7.0 COMPONENT CHECKLIST

<i>QUANTITY</i>	<i>DESCRIPTION</i>
1	Firebox and burner assembly.
1	Decorative frame, one of several finishes.
10	Individual ceramic pebbles (pebble effect option only)
1	Bag of heat resistant glass crystals (glass fuel bed versions only)
1	Set of manufacturers instructions and warranty card.
1	Cable fixing kit comprising; 2 cables, 2 tensioners, 2 clamps, 4 fixing eyes, 4 fibre rawl plugs.
1	Screw pack
3	Lengths of self adhesive sealing strip.
1	Rubber grommet.
1	Allen key

4.0 SITE REQUIREMENTS

The fireplace opening should be inspected and repairs made where necessary. Any chair brick will usually require removal.

The opening WIDTH and HEIGHT dimensions should be between 365mm and 440mm wide, and 540mm to 575mm high.

Opening DEPTH should be 285mm. Opening DEPTHS include any plaster or infill panels which form part of the installation.

This appliance required a natural draught flue system which may be one of the following;

225mm x 225mm (9in x 9in) brick or stone.

175mm (7in) minimum diameter lined brick or stone.

175mm (7in) minimum diameter twin wall flue conforming to BS 715.

Any existing under grate draught device must be sealed off.

The opening wall must be non-combustible and have adequate flat surface for appliance sealing.

The appliance requires a hearth with non-combustible surface of at least 12mm thick. The top surface must be at least 50mm above the surrounding floor level, or be surrounded by a raised edge or fender 50mm high.

To enable the products of combustion to be cleared properly up the flue, the outlet at the back of the appliance must have a minimum 50mm clearance between it and the back wall of the opening or other obstruction. The area immediately above the outlet must form a smooth path into the flue. Any type of fire surround used with this appliance must be adequately sealed to the wall and floor.

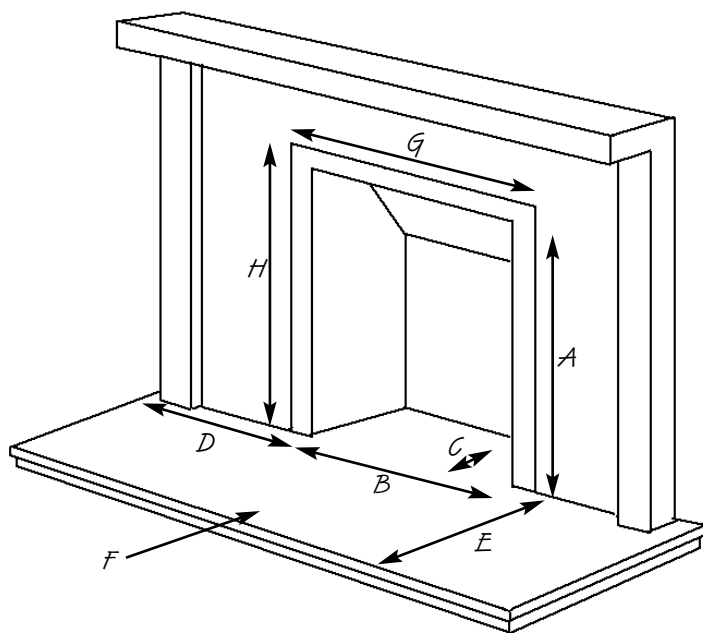

- A. Opening height: 540mm min/575 mm max.
- B. Opening width: 365mm min/440mm max.
- C. Mounting depth: 285mm
- D. Hearth must extend minimum of 150mm either side of the opening.
- E. Hearth must extend minimum of 325mm in front of the opening.
- F. Non-combustible hearth must be a minimum of 50mm in height, or be surrounded by 50mm high fender.
- G. 470mm, this area must be flat and vertical to ensure a good seal.
- H. 585mm, this area must be flat and vertical to ensure a good seal.

A combustible shelf may be fixed to the wall above the fire, providing that it complies with the dimensions given in the user section of these instructions. A non-combustible shelf may be fitted to within 10mm of the top edge of the fireframe.

Combustible materials, such as wood, may be fitted to within 100mm (4in) of either side of the frame of the fireplace opening, providing the forward projection does not exceed 100mm (4in).

Any combustible side walls must be at least 500mm to the side of the radiant heat source.

As with all heating appliances, any decorations, soft furnishings, and wall coverings (i.e. flock, blown vinyl and embossed paper) positioned too close to the appliance may discolour or scorch.

2.0

APPLIANCE DATA

	<u>NV models</u>	<u>PLUS models</u>
Gas Group	G20 Natural Gas CAT I2H	G20 Natural Gas CAT I2H
Inlet Pressure	20 mbar	20 mbar
Max Energy Input (gross)	6.8 kW	10 kW
Min Energy Input (gross)	4.0 kW	4.0 kW
Pilot Energy Input (gross)	210 W	210 W
Setting Pressure - High (cold)	7.0 mbar (+/- 0.5mbar)	13.5 mbar (+/- 0.75mbar)
Setting Pressure - High (hot)	7.5 mbar (+/- 0.5mbar)	14.0 mbar (+/- 0.75mbar)
Setting Pressure - Low (hot)	2.5 mbar (+/- 0.5mbar)	2.5 mbar (+/- 0.75mbar)
Main Injector Burner	Stereo 702	Stereo 702
Gas Inlet Connection	8mm Inlet Restrictor Elbow	8mm Inlet Restrictor Elbow
Gas Control Valve	Dungs BM 733	Dungs BM 733
Ignition	Integral Piezo spark	Integral Piezo spark
Spark Gap	3.5 to 4.5mm	3.5 to 4.5mm
Weight	10 KG	10 KG
Purpose Provided Ventilation	Normally none	15cm ²

Please see Data Badge affixed to appliance for current data.

This appliance is for use only with the gas type, and at the pressure stated on the appliance Data Badge, and is for decorative purposes.

3.0

INSTALLATION REQUIREMENTS

This appliance MUST NOT be installed into a room containing a bath or shower, or where steam may be present. The fire has been designed to fit into a builders' opening or fireplace conforming to BS 1251 (and meeting certain dimensional requirements), or a suitable flue box complying with the constructional requirements of BS 715. The flue box must be installed onto a suitable non-combustible insulating surface at least 12mm thick, covering the entire base area of the box.

The flue must have an effective height of at least three meters, as measured from the hearth to the top of the flue. Any flue damper plates or restrictors should be removed and no other restriction fitted to the flue. Where removal is not practical, the restriction must be fixed in the fully open position.

A natural draught flue system is required, and if previously used for solid fuel or oil burning, the flue and chimney must be swept prior to appliance installation. The flue must be checked before installation by using a smoke pellet or similar to ensure proper draw and that leakage is not evident at any joints. Repair and re-test as necessary before the appliance is installed.

The flue must be connected to only one fireplace, and the flue must not vent more than one appliance (i.e. not shared with a gas back boiler). There must be no opening in the flue apart from the one that the appliance is installed into, and the one venting the gases into the air. A suitable terminal may be fitted, such as class GC1, as regulations allow.

This appliance is suitable for use with a "lightweight" surround and back panel of 150°C minimum rating.

<i>Section</i>	<i>Contents</i>	<i>Page No.</i>	<i>Section</i>	<i>Contents</i>	<i>Page No.</i>
1.0	Important Notes	1	10.0	Gas Supply	6
2.0	Appliance Data	2	11.0	Fitting the Firebox	6
3.0	Installation Requirements	2	11.1	Cable Fixing	6
4.0	Site Requirements	3	11.2	Gas Connection	6
5.0	Ventilation	4	12.0	Fuel Bed Layout	7
6.0	Unpacking the Appliance	4	13.0	Fitting the frame	7
7.0	Component Checklist	4	14.0	Testing & Commissioning	7
8.0	Preparing the Appliance	5	15.0	Servicing	9
9.0	Preparing the Opening	5	16.0	Troubleshooting Guide	11

1.0 IMPORTANT NOTES

This fire is an Inset Live Fuel Effect Gas Fire providing radiant warmth. It is designed to operate on Natural Gas only. See Data Plate on appliance.

It is the LAW that all gas appliances and fittings are installed by a competent person (such as a CORGI registered fitter) and in accordance with the Gas Safety (Installation and Use) Regulations 1998, the relevant British Standards for Installation, Codes of Practice and in accordance with the Manufacturers' Instructions. The installation shall also be carried out in accordance with the following regulations:

The Building Regulations issued by the Department of the Environment, the Building Standards (Scotland) (Consolidation) Regulations issued by the Scottish Development Department.

BS 5871 part 2

BS 5440 part 1

BS 8303

BS 1251

BS 6891

BS 6461 part 1

Note - For Republic of Ireland, reference should be made to the relevant standards governing installation, particularly in regard to flue sizing and ventilation. See IS813, ICP3, IS327 and any other rules in force.

Failure to comply with these regulations could lead to prosecution and deem the warranty invalid.

This appliance is free from any asbestos material. Refractories and the fuel bed components of certain models are constructed from ceramic fibre.

INSTALLATION INSTRUCTIONS

Preliminary Notes Before Installation

This appliance is an Inset Live Fuel Effect appliance which provides radiant warmth utilising the latest type burner technology.

The fire is designed to fit various types of fireplaces and natural draught flues as listed in the Installation Requirements.

The appliance must be installed by a competent person in accordance with Gas Safety (Installation and Use) Regulations 1998. It is strongly recommended that a CORGI registered engineer be used for this purpose.

Read all these instructions before commencing installation.

This appliance must be installed in accordance with the rules in force and only used in a sufficiently ventilated space.

The appliance is designed for installation on to a non-combustible hearth which must project at least 300mm forward of the appliance fuel bed.

This appliance is factory set for operation on the gas type, and at the pressure stated on the appliance data plate.

This appliance is available with a number of fuel effect options. These instructions cover all fuel effect options. See the relevant sections of these instructions for further details.