

Installation, User and Service Manual

Ferrolì

Stainless Steel

Unvented Hot Water Cylinder

Storage Capacities 150, 200, 250, 300, 400 & 500 Litres

Ferrolì Hot Water Cylinder

Installation, User and Service Manual

Important -This Manual Should Be Left With The Cylinder After Installation

Index

<u>Section</u>	<u>Page</u>
1 Introduction	2
2 Technical specifications	3
3 Check list	3
4 General requirements	4
5 Primary circuit installation	6
6 Secondary circuit installation	9
7 Discharge arrangement	11
8 Electrical installation	14
9 Filling and commissioning	16
10 Servicing and maintenance	17
11 Fault finding	18
12 User instructions	19
13 Warranty	19
14 Installation, Commissioning and Service Record	20

1. Introduction

The **Ferrolì** hot water cylinder is manufactured from stainless steel and is suitable for use on “unvented” hot water systems. The indirect heat exchange surfaces are designed to provide a rapid heat up. The unit incorporates a 3kW electric immersion heater as a “backup”. The unit is supplied complete with all the necessary safety equipment to comply with legislation governing the installation of such systems. The immersion heater and temperature and pressure relief valve is factory fitted.

2. Technical specifications

<u>Model Number</u>	<u>150</u>	<u>200</u>	<u>250</u>	<u>300</u>	<u>400</u>	<u>500</u>
Storage capacity - litres	150	200	250	300	400	500
Overall diameter - mm	530	530	530	530	680	680
Overall including immersion heater - mm	605	605	605	605	725	725
Overall height - mm	1130	1490	1790	2100	1700	2000
Weight when full - kg	195	250	310	360	465	570
Primary flow/return connections - mm/”	22	22	22	22	2”	2”
Cold feed/hot draw off connections - mm22	22	22	28	28	28	
Maximum water supply pressure - bar	12	12	12	12	12	12
System operating pressure (pre-set) - bar	3	3	3	3	3	3
Expansion vessel charge pressure - bar	3	3	3	3	3	3
Expansion relief valve set pressure - bar	6	6	6	6	6	6
T & Prelief valve set pressure - bar	7	7	7	7	7	7
T & P Lift temperature - °C	90	90	90	90	90	90
Maximum primary working pressure - bar	3	3	3	3	3	3

Performance:

Hot water generation time in minutes from 10 to 60°C for ‘ Indirect ’ cylinder	16	18	19	20	22	25
Regeneration time in minutes for 70% of contents for ‘ Indirect ’ cylinder from 40-60°C	8	8	8	10	10	12

3. Check list

Cylinder assembly 150 ltr	1	-	-	-	-	-
Cylinder assembly 200 ltr	-	1	-	-	-	-
Cylinder assembly 250 ltr	-	-	1	-	-	-
Cylinder assembly 300 ltr	-	-	-	1	-	-
Cylinder assembly 400 ltr	-	-	-	-	1	-
Cylinder assembly 500 ltr	-	-	-	-	-	1
Expansion vessel – 12 ltr	1	-	-	-	-	-
Expansion vessel – 18 ltr	-	1	-	-	-	-
Expansion vessel – 24 ltr	-	-	1	1	-	-
Expansion vessel – 35 ltr	-	-	-	-	1	-
Expansion vessel – 50 litre	-	-	-	-	-	1
Pressure reducing valve – 22mm	1	1	1	1	1	-
Pressure reducing valve – 28mm	-	-	-	-	-	1
Expansion relief valve - 22mm	1	1	1	1	1	-
Expansion relief valve – 28mm	-	-	-	-	-	1
T/P valve, pre fitted & tundish	1	1	1	1	1	1
22mm motorised valve	1	1	1	1	1	-
28mm motorised valve	-	-	-	-	-	1
Control/limit thermostat, part No	1	1	1	1	1	1
Immersion heater pre fitted, part No	1(2)	1(2)	1(2)	1(2)	1(2)	1(2)

4. General requirements

4.1. The **Ferroli** hot water cylinder **MUST** be installed by a competent person in accordance with section **G3** of the current **Building Regulations**.

4.2. Important - It is important that the installer reads and understands these instructions, unpacks and familiarises themselves with the equipment before commencing the installation. Failure to observe these installation instructions could invalidate the warranty.

4.3. Water supply - The warranty requires that the water to be heated be of drinking water quality and that if water treatment equipment is installed, it must function correctly.

The unit, where possible should be fed via an appropriate diameter supply pipe. It requires a supply pressure of 1.5 bar with a flow rate of at least 20 litres per minute as a minimum for it to function. Even with these rates, flow from the outlets will be reduced if several outlets are used simultaneously. Generally speaking, the higher the supply pressure, the better the system will function. The cylinder control equipment is factory set to limit the system operating pressure to 3 bar. The maximum supply pressure into the pressure-reducing valve is 12 bar.

4.4. Taps and fittings - All taps and fittings incorporated in the unvented system should have a rated operating pressure of 7 bar or above.

4.5. Location – The unit is designed to be floor standing, vertically mounted, indoors, in a frost-free environment. When choosing a suitable location for the cylinder, consideration should be given to the routing of the discharge pipe to a convenient point and also the availability of an adequate power supply for connecting the immersion heater(s).

The cylinder may stand on any flat and level surface without any special foundation preparations, provided that it is sufficiently robust to support the full weight of the cylinder. (See Technical specifications for weights)

The position of the cylinder should be such that easy access is provided for servicing the controls and replacing the immersion heater should the need arise.

Generally, pipe runs should be made as short as possible and lagged to prevent heat loss.

4.6. Storage and handling – If the cylinder is not being installed immediately, it should remain in its packaging with all pipe end protective caps in situ to prevent damage. We recommend that the cylinder be transported to its installation position with the outer packaging in place.

4.7. Pipework connections – All Pipework connections to the cylinder **MUST** be made in accordance with Fig 1.

Pipework connections.

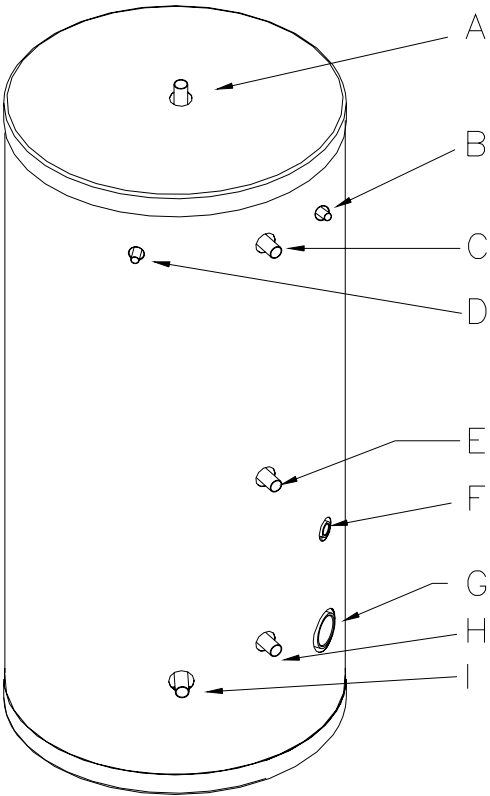

KEY	
LETTER	DESCRIPTION
A	EXPANSION VESSEL (OPTIONAL)
B	T & P GAUGE
C	HOT WATER OUTLET
D	T & P VALVE
E	HEATING WATER RETURN
F	THERMOSTAT POCKET
G	IMMERSION HEATER
H	HEATING WATER FLOW
I	COLD WATER INLET

Fig 1

5. Primary circuit installation

5.1. The **Ferrolli** cylinder is suitable for connecting to most fully pumped domestic gas or oil fired central heating boilers working on open vented or sealed systems and having a maximum working pressure of 3 bar and a maximum working temperature of 90°C. Gravity circulation systems should be avoided.

5.2. Systems - For the best results we recommend that the cylinder be connected to an “**S**”plan type system that gives priority to domestic hot water (**DHW**) production. This particular system allows all the boiler’s energy to go into satisfying the hot water demand before switching over on to central heating duty.

5.3. Connections -The primary flow and return connections should be made in accordance with Fig 1 using compression fittings, (not supplied).

5.4. The 2 port valve -To prevent gravity circulation when the boiler switches off, the 2 port motorised valve supplied with the unvented hot water kit **MUST** be fitted in the primary flow pipe to the cylinder and wired in accordance with the diagram.

5.5. Hard water areas – If the cylinder is to be used in a hard water area, we recommend that the primary flow temperature be limited to 75°C. This will help reduce the migration of suspended solids in the water and help prevent the build up of lime scale.

“W” Plan wiring layout and system schematic.

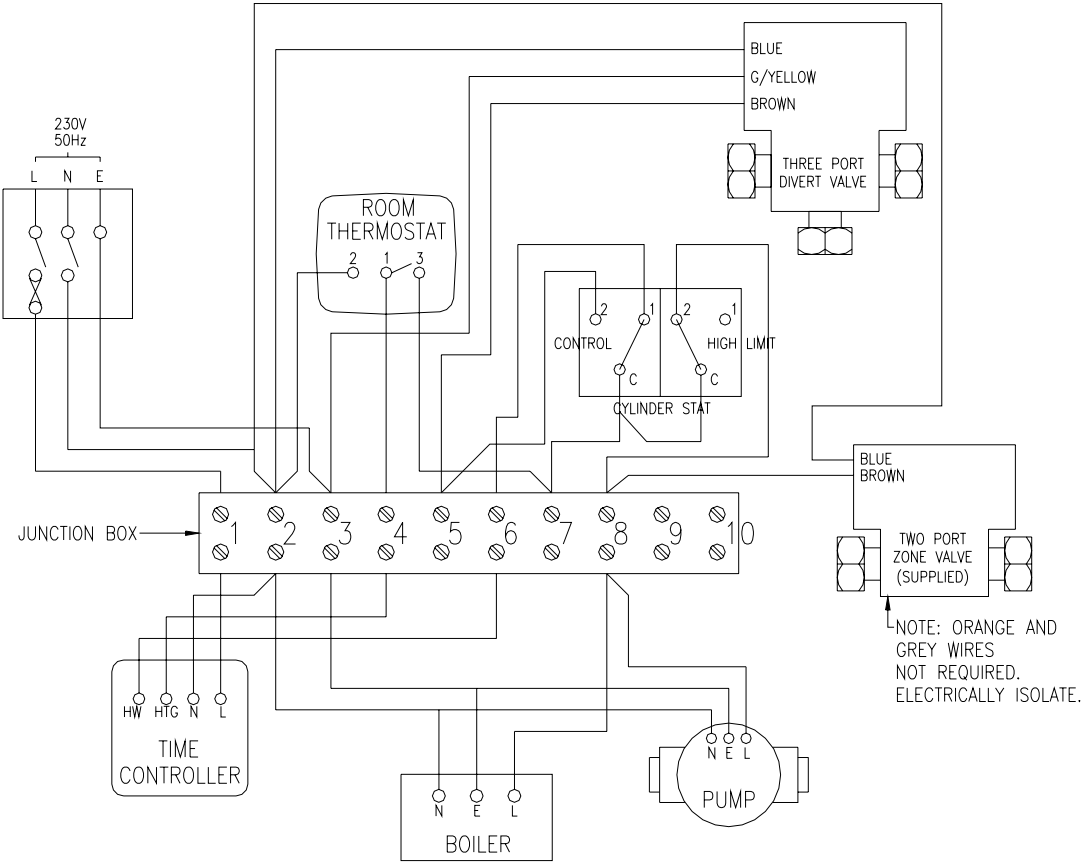
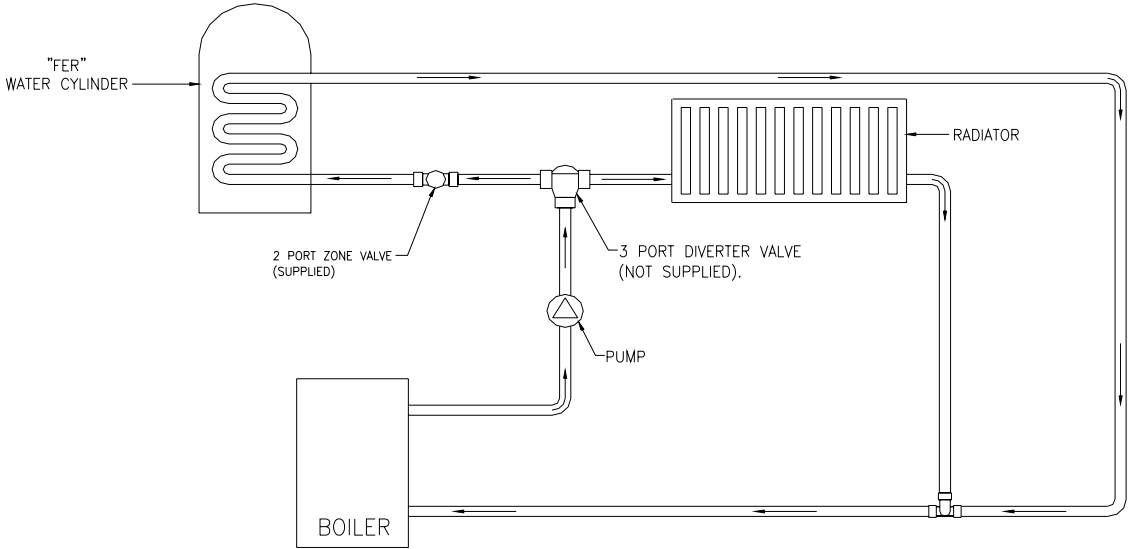

Fig 2

“S” Plan wiring layout and system schematic.

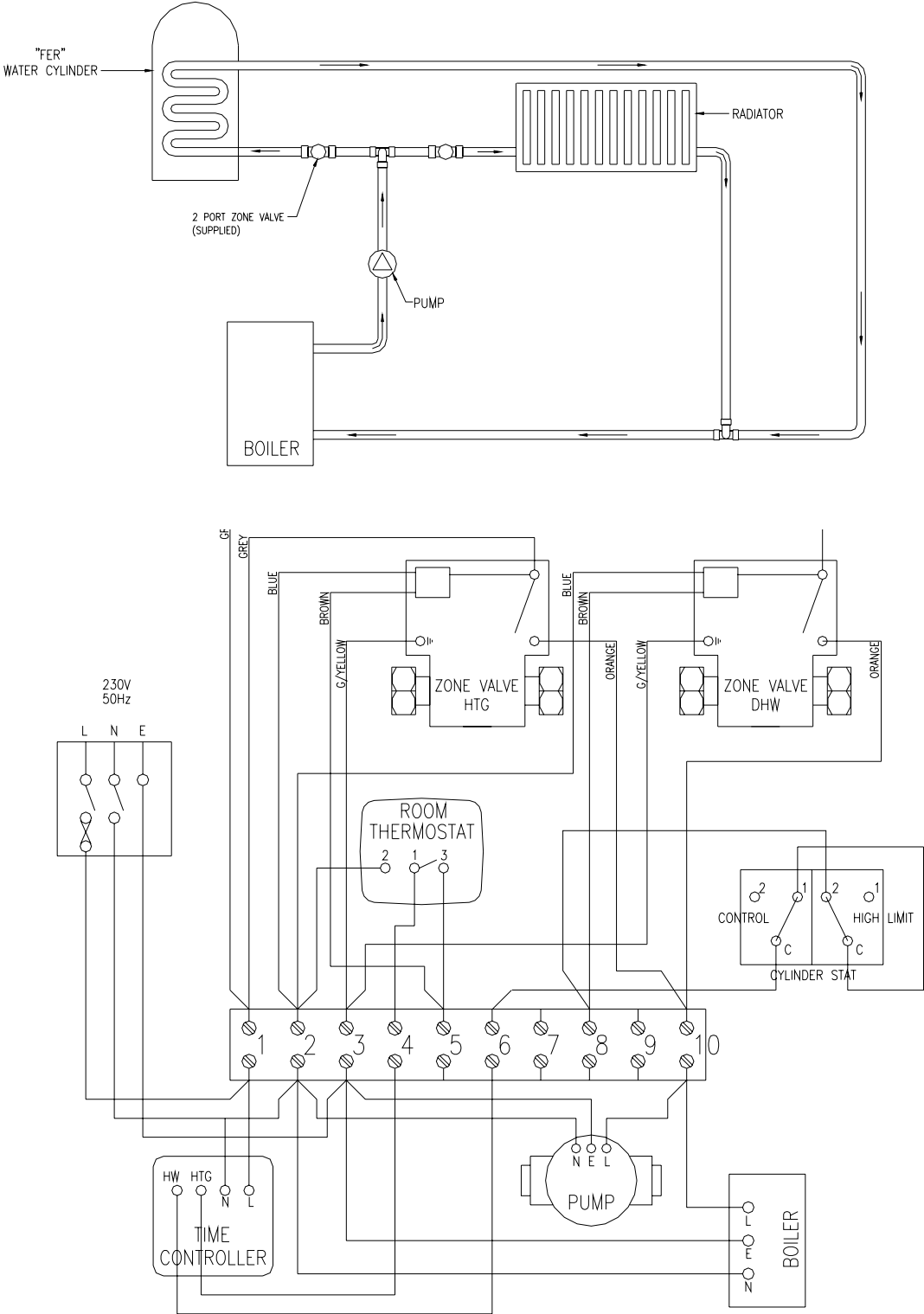

Fig 3

6. Secondary circuit installation.

6.1. - Connections. Secondary circuit connections **MUST** be made to the cylinder in accordance with Fig 1 and Fig 4. A drain cock (not supplied) should be fitted in the position shown in Fig 4 to facilitate draining of the cylinder.

6.2. - Cold water supply – Where possible, for best results, the cylinder should be fed by an uninterrupted supply pipe into the pressure reducing valve (PRV) with a supply pressure of between 3 and 12 bar maximum. In the UK supply pressures this high are not always available. However the system will still work satisfactorily with pressures below this. The cylinder should not be used on any system with a supply pressure below 1.5 bar and a flow rate of less than 20 litres per minute.

6.3. - Temperature and pressure relief valve – The temperature and pressure relief valve (TPV) is supplied factory fitted to the cylinder. The valve is pre calibrated to lift at 7 bar or 90°C and any attempt to adjust it will invalidate the warranty.

6.4. - Expansion vessel – A suitable expansion vessel with a pre-charge pressure of 3 bar is supplied which **MUST** be connected into the cold water supply side between the expansion relief valve and the cylinder. The expansion vessel **MUST** be positioned with the entry point at the bottom. **ONLY USE THE EXPANSION VESSEL SUPPLIED.**

IMPORTANT: Regular checks must be carried out to ensure that the expansion vessel is correctly pressurised to 3 bar at all times.

6.5. - Pressure reducing valve – Taking due account of the directional arrow, fit the pressure reducing valve (PRV) in accordance with Fig 4. This can be connected to a cold supply with a maximum pressure of 12 bar.

6.6. - Expansion relief valve – Fit the expansion relief valve (ERV) in accordance with Fig 4. This valve has been pre-set to lift at 6 bar. No other valve should be fitted between the expansion relief valve and the cylinder.

6.7. - Check valve – Taking due account of the directional arrow, fit the check valve (CV) in accordance with Fig 4.

6.8. - Secondary circulation – If the installation requires a secondary circulation circuit, a return leg, which incorporates a check valve, should be connected via the cold feed using a swept tee.

IMPORTANT: If a secondary circulation circuit is installed then a larger expansion vessel may be required to handle the increase in volume. **PLEASE CONTACT FOR ADVICE**

6.9. - Sterilisation – It is important in commercial applications to ensure that the contents of the hot water cylinder are delivered to pipework in a sterile condition. Distribution legs should be kept short and where secondary circulation is used the temperature in the cylinder should not consistently fall below 55°C. Arrangements should be made by means of a pump to destratify the cylinder on a regular basis. The destratification/sterilisation process must be controlled by a time clock, or time clock and thermostat. It is undesirable to use excessive flow rates and further advice on suitable kits is available from the manufacturer.

6.10. Tundish – The tundish must not be positioned above or in close proximity of any electrical current carrying devices or wiring.

Secondary circuit arrangement

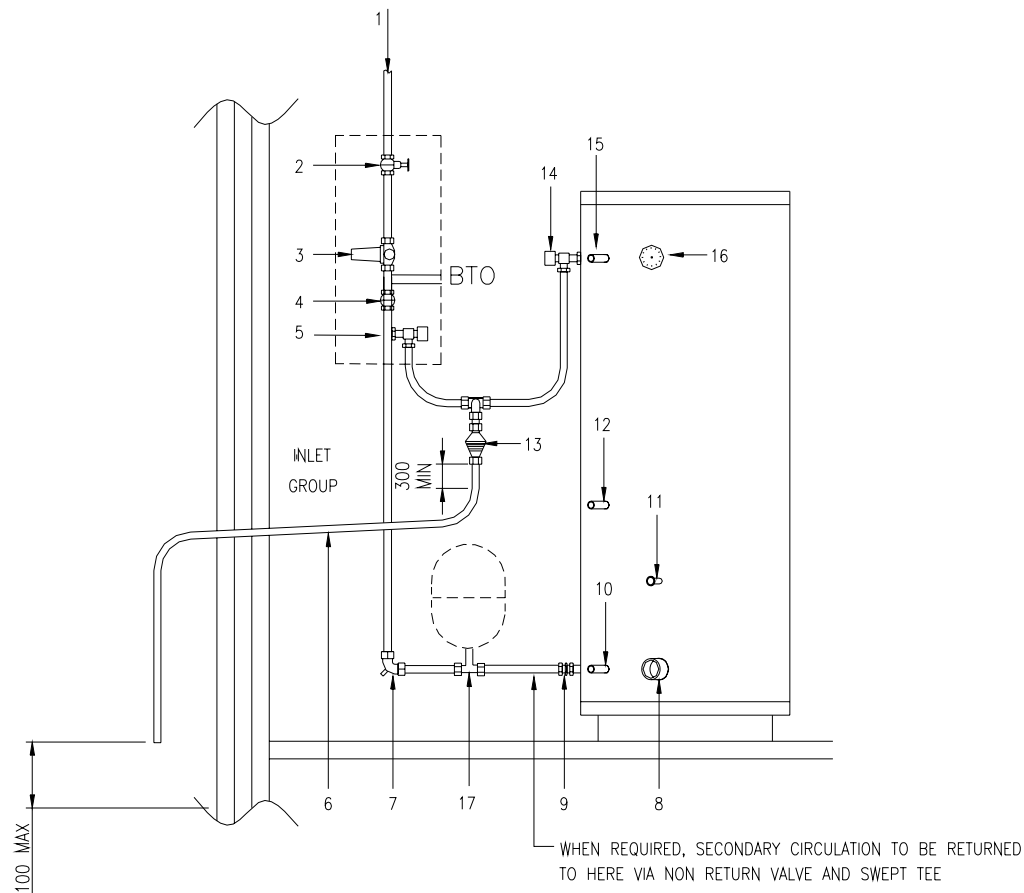

Fig 4

Items 3, 4 and 5 may be supplied as a composite group, incorporating the balanced take off point. A check valve should be inserted into all B.T.O. supply lines.

1	MAINS COLD WATER SUPPLY
2	STOP COCK (NOT SUPPLIED)
3	PRESSURE REDUCING VALVE – SET 3 BAR
4	CHECK VALVE
5	EXPANSION RELIEF VALVE - SET 6 BAR
6	DISCHARGE PIPE 22mm DIA (SEE SECTION 7)
7	DRAIN COCK (NOT SUPPLIED)
8	IMMERSION HEATER 230v – 3 kW – 50 Hz
9	COLD WATER INLET CONNECTION
10	PRIMARY FLOW CONNECTION – 22mm DIA
11	CONTROL THERMOSTAT SENSOR POCKET
12	PRIMARY RETURN CONNECTION – 22mm DIA
13	TUNDISH
14	TEMPERATURE AND PRESSURE RELIEF VALVE. SET 7 BAR / 90°C
15	HOT WATER OUTLET
16	TEMPERATURE AND PRESSURE GAUGE
17	EXPANSION VESSEL

7. Discharge arrangement.

Tundishes must be installed in a position so that they are clearly visible by the user. In addition, the discharge pipe from the Tundish should terminate in a safe place where there is no risk to persons in the vicinity of the discharge, be of metal and:

(a) Be at least one pipe size larger than the normal outlet size of the safety device unless its total equipment hydraulic resistance exceeds that of a straight pipe 9 m long, i.e. discharge pipes between 9 m and 18 m equivalent resistance length should be at least two sizes larger than the normal outlet size of the safety device, between 18 m and 27 m at least three sizes larger and so on. Bends must be taken into account in calculating the flow resistance. Refer to the diagram, tables and worked example detailed in Fig 5.

(b) Have a vertical section of pipe at least 300 mm long below the Tundish before any elbows or bends in the Pipework.

(c) Be installed with a continuous fall

(d) Have discharges visible at both Tundish and the final point of discharge, but where this is not possible or practically difficult, examples of acceptable discharge arrangements are:

- Ideally below a fixed grating and above the water seal in a trapped gully
- Downward discharge at low level, i.e. up to 100 mm above external surfaces such as car parks, hard standings, grassed areas, etc. are acceptable providing that where children play or otherwise come into contact with discharges, a wire cage or similar guard is positioned to prevent contact whilst maintaining visibility.
- Discharge at high level, e.g. into a metal hopper and metal down pipe with the end of the discharge pipe clearly visible (Tundish visible or not) or onto a roof capable of withstanding high temperature discharges of water and 3 m from any plastic guttering system that would collect such discharges (Tundish visible).
- Where a single pipe serves a number of discharges such as in blocks of flats, the number served should be limited to not more than six systems so that any installation discharging can be traced reasonably easily. The single common discharge pipe should be at least one pipe size larger than the largest individual discharge pipe to be connected. If unvented hot water stored systems are installed where discharges from safety devices may not be apparent i.e. in dwellings occupied by blind, or disabled people, consideration should be given to the installation of an electrically operated device to warn when discharge takes place.

Warning Notice – The discharge will consist of scalding water and steam. Asphalt, roofing felt and non-metallic rainwater goods may be damaged by such discharges.

Typical discharge pipe arrangement.

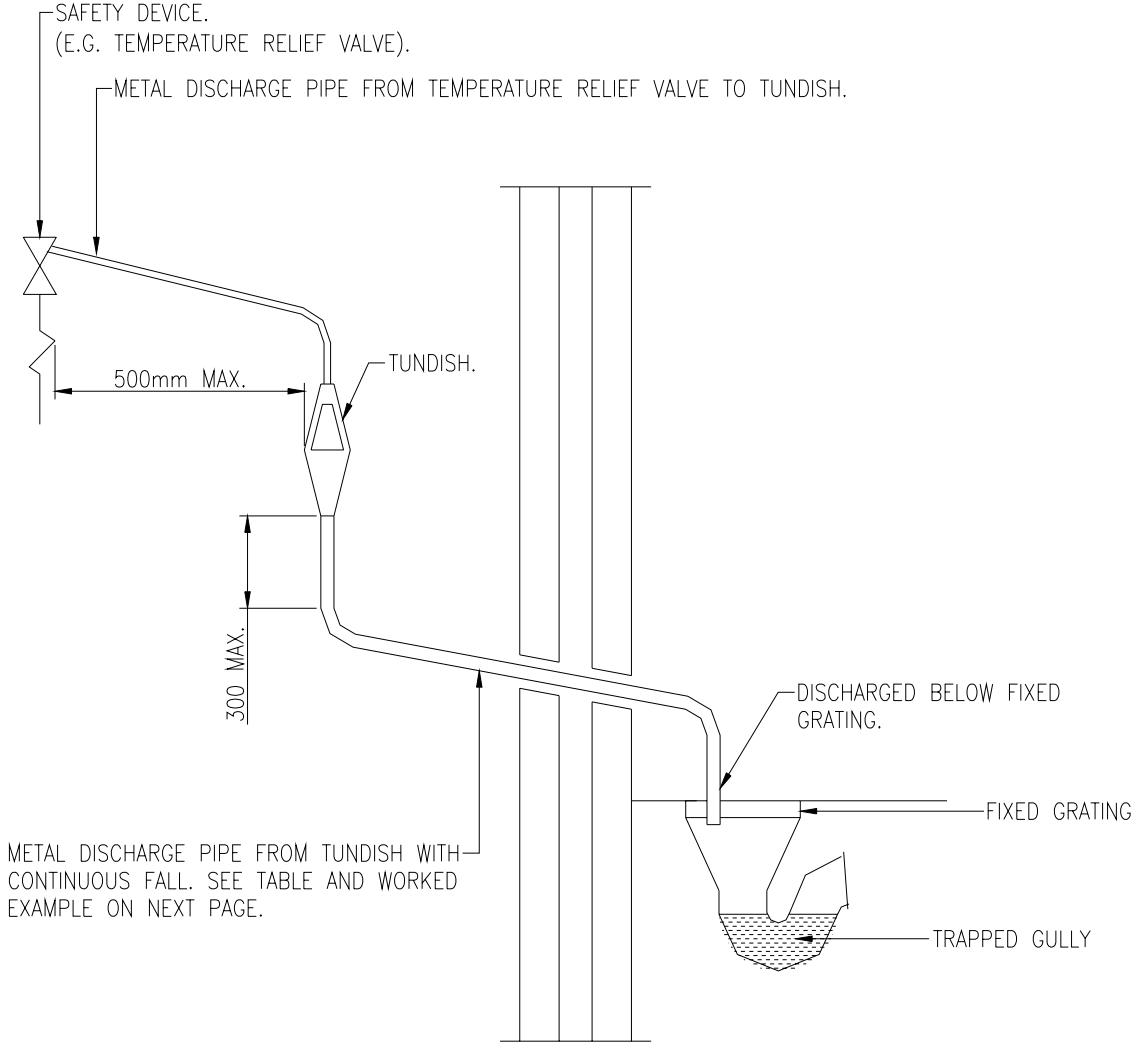

Fig 5

Sizing of copper discharge pipe “D2” for common temperature relief valve outlet sizes

Valve outlet size, diameter in ‘inches’	Min size of discharge pipe D1 in ‘mm’	Min size of discharge pipe D2 from tundish in ‘mm’	Max resistance allowed, expressed as a length of straight pipe, i.e. no elbows or bends.	Resistance created by each elbow or bend in ‘m’
1/2	15	22	up to 9	0.8
		28	up to 18	1.0
		35	up to 27	1.4
1	28	35	up to 9	1.4
		42	up to 18	1.7
		54	up to 27	2.3

Worked example

The example below is for a ½” diameter temperature relief valve with a discharge pipe (D2) having 4 No elbows and a length of 7 m from the tundish to the point of discharge.

From

Maximum resistance allowed for a straight length of 22mm copper discharge pipe (D2) from a ½” diameter temperature relief valve is: 9.0 m.

Subtract the resistance for 4 No 22mm elbows at 0.8 m each = 3.2 m.

Therefore, the maximum permitted length equates to: 5.8 m.

5.8 m is less than the actual length of 7 m, therefore, calculate the next largest size.

Maximum resistance allowed for a straight length of 28mm pipe (D2) from a ½” diameter temperature relief valve equates to: 18 m.

Subtract the resistance for 4 No 28mm elbows at 1.0 each = 4 m.

Therefore the maximum permitted length equates to 14 m.

As the actual length is 7 m, a 28mm diameter copper pipe will be satisfactory.

8. Electrical installation

WARNING: THIS EQUIPMENT MUST BE EARTHED.

All electrical wiring must be carried out by a competent person and in accordance with the **current I.E.E. Wiring Regulations**. A suitable “Earthing” point is provided on the cylinder pedestal directly below the immersion heater (see Fig 1).

The control equipment supplied will ensure that the cylinder functions safely. From an economic and convenience point of view, it is intended that these controls operate in conjunction with other control packages for example Honeywell “S”, “W” or “Y” plan systems, which incorporate a programmable time clock etc.

8.1. The immersion heater-A 3kW 230v 50Hz immersion heater is pre fitted to the cylinder at the factory. It should be wired in accordance with the instructions given in Fig 6. The cable **MUST** be routed through the strain relief bush. We recommend that the control thermostat is set at 60°C, the high limit trip is factory set at 85°C. The immersion heater conforms to EEC Directive 76/889 for radio interference and complies with BS 800:1977.

WARNING: Never fit an immersion heater without a thermal cut-out. The manufacturers listed spare only should be used.

8.2. The indirect temperature controller-The control and high limit thermostat for use with indirect systems is supplied separately with the unvented hot water safety kit. It should be fitted into the sensor pocket in the cylinder (see Fig 1 for position). The control thermostat has an adjustment range between 30°C and 90°C, however it is recommended this it be set to 60°C **WARNING:** The manual re-set high limit thermostat **MUST NOT** under any circumstances be bypassed. This is pre-set to 80°C and to prevent nuisance tripping the control thermostat should always be at least 15°C below this.

8.3. The 2 port valve -To prevent gravity circulation when the boiler switches off, the 2 port motorised valve supplied with the unvented hot water kit **MUST** be fitted in the primary flow pipe to the cylinder and wired in accordance with Figs 2 or 3 (depending on system design), to comply with current legislation.

Immersion heater installation and wiring instructions

- a) Ensure the mains voltage corresponds to the voltage rating of the immersion heater as shown on the rating label on the terminal cover.
- b) Install the immersion heater into the domestic hot water cylinder using the gasket provided. Use a shaped spanner, Stillsons should not be used. The use of sealing compound is not recommended.
- c) Wire the immersion heater in accordance with the wiring diagram below. It should be wired through a double pole isolator switch or controller, having contact separation of at least 3 mm, using 1.5mm sq. flexible cable, 85°C rubber insulated HOFRR sheathed, to comply with BS 6141 table 8 and must be fully earthed.
- d) The BEAB approval certification on this immersion heater only applies if rod type thermostats, types Sunvic VKL or Cotherm SHD are used. The temperature setting of the control thermostat must not exceed 60°C.
- e) In the event of the manual reset cut-out operating, isolate the immersion heater from the mains supply, investigate and identify the cause of the operation of this cut-out, rectify the fault before manually resetting the cut-out via the reset button on the cut-out. Finally switch the mains electricity supply back on.

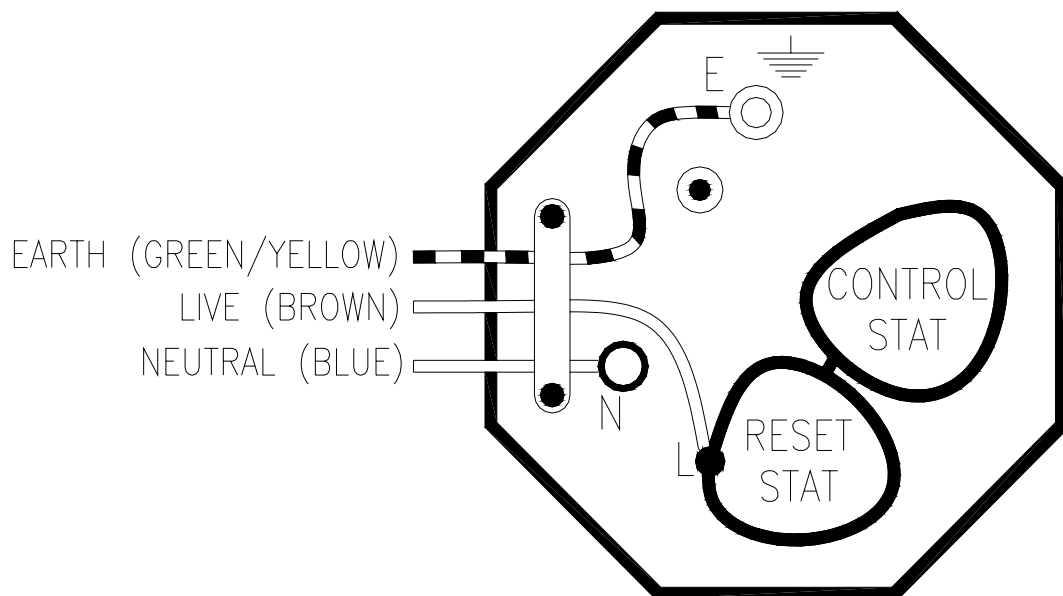

WARNING: THIS APPLIANCE MUST BE EARTHED.

Fig 6

9. Filling and commissioning-

9.1. Check that the expansion vessel charge pressure is 3 bar.

9.2. Check that all connections are made tight including the immersion heater.

9.3. Open the main stopcock and fill the secondary system first. Open successive taps (hot and cold) starting with the tap furthest from the cylinder. Leave each tap open for a few moments to allow all air and possibly debris from the system to exit. Manually lift (by rotating the knob) both the expansion relief (EV) and the temperature and pressure relief valve (TPV) for a short period to remove trapped air from behind the valve seating and to prove the correct function of the discharge arrangement.

9.4. Check all joints for leaks, rectify as necessary.

9.5. Check that the control and high limit settings for the indirect system and the immersion heater are as required.

9.6. Fill the primary side, (note:- it will be necessary to manually open the 2 port valve whilst filling the system, this is achieved by moving the lever on the valve head sideways). Check for leaks and rectify as necessary. Vent all heat emitters of air and, following the manufacturers lighting instructions, ignite the boiler.

9.7. Check that while the cylinder is heating up, no water issues from either the expansion relief or the temperature and pressure relief valve and, when the cylinder reaches temperature, which the 2 port valve closes.

10.Servicing and maintenance.

10.1. Servicing and maintenance must only be carried out by a competent unvented hot water installer or by Ferroli authorised personnel.

10.2. Before any work whatsoever is carried out on the installation, it **MUST** first be isolated from the mains electricity supply.

10.3. **WARNING:** both the primary and secondary systems will contain very hot water that will scald, therefore care should be taken when opening any joints, seals or valves.

10.4. Only use spare parts authorised by Ferroli. The use of unscheduled spare parts will invalidate the warranty.

10.5. Draining the cylinder – When draining the cylinder, always switch off the boiler and the immersion heater first. Turn off the water supply at the stopcock (see Fig 4). Connect a hose pipe to the drain cock (see Fig 4) and route it to a convenient gully. Open the drain cock and all hot taps that are served by the cylinder. The cylinder may take several minutes to empty completely.

10.6. In hard water areas it may be necessary from time to time to remove and de-scale the immersion heater element. Replace the gasket each time it is removed.

10.7. Remove the cartridge from the pressure reducing valve (PRV). Check the strainer and if necessary remove any debris from in front of it. Replace the cartridge.

10.8 .Check the charge pressure in the expansion vessel and top up as necessary. The charge pressure should be **3.0 bar**.

10.9. Whilst the hose pipe is connected, the drain cock open and with the immersion heater removed, the cylinder may be flushed out to remove any debris, sand or lime scale particles that may have collected in the bottom by using a further hose pipe connected to the cold water main.

10.10. Close the drain cock, disconnect the hose, refit the immersion heater and close all hot water taps before reopening the stopcock. Allow the cylinder time to fill whilst checking for any leaks. Release any air from the system by opening each hot water tap individually, starting with the one furthest from the cylinder.

10.11. Manually lift the expansion relief and temperature and pressure relief valve one at a time, every 12 months (more frequently in hard water areas) to prevent debris from building up behind the valve seat. Whilst carrying out this operation, check that the discharge to waste is unobstructed. Check that each valve seals correctly when released. As the valves are pre-calibrated, they require no further maintenance.

10.12. Finally switch on the mains electricity supply to the immersion heater and the boiler. As the system heats up, check again for any leaks and rectify as necessary.

11. Fault finding.

Notice: Disconnect electrical supply before removing any electrical equipment cover.

<u>Fault</u>	<u>Possible cause</u>	<u>Remedy</u>
No hot water	1. Mains supply off 2. Strainer blocked 3. Pressure reducing valve (PRV) incorrectly fitted	1. Open stopcock 2. Turn water supply off, remove strainer and clean. (see 10.6) 3. Re-fit correctly
Water from hot taps is cold	1. Programmer set to heating only or not switched on 2. Central heating boiler malfunction 3. High limit thermostat has tripped 4. Motorised valve malfunction	1. Set programmer to call for hot water 2. Check boiler operation if faulty consult your boiler manufacturers instructions 3. Check and re-set 4. Check wiring and/or plumbing connections to motorised valve
Intermittent water discharge	1. Expansion vessel has lost its charge pressure	1. Turn off stopcock open a hot water tap check vessel charge pressure and recharge to 3 bar
Continuous water discharge	1. Pressure reducing valve (PRV) not working 2. Expansion relief valve not seating correctly 3. Temperature and pressure relief valve not seating correctly	1. Check pressure from PRV if greater than 3 bar replace cartridge 2. Manually lift the valve once or twice to clear any debris from theseat otherwise replace valve 3. Same remedy as above

12. Users instructions.

12.1 Your Ferroli unvented hot water cylinder has been designed to give many years of trouble free service and is made from hygienic high grade stainless steel. It includes a 3 kW electric immersion heater for times when your central heating is switched off, during the summer for instance.

12.2. The flow temperature of the hot water can be set to your requirements on the immersion heater up to 60°C and the indirect side thermostat up to 65°C. These temperatures should not be set any higher otherwise nuisance tripping of the high limit thermostat will occur. If you are in any doubt, these adjustments should be best left to a qualified electrician.

12.3. When a hot tap is turned on there may be a short surge of water, this is quite normal with unvented systems and does not mean there is a fault.

12.4. When you first fill a basin the water may sometimes appear milky. This is due to very tiny air bubbles in the water, which will clear very quickly.

12.5. WARNING: If water issues from the temperature and pressure relief valve (TPV) or from the expansion relief valve (ERV) seek expert advice immediately.

13. Warranty

13.1. Ferroli guarantee all electrical and mechanical controls supplied with the cylinder for a period of 2 years from the date of purchase provided that they have been installed for their intended use by a competent person and have not been modified in any way.

13.2. In addition Ferroli also guarantees the stainless steel hot water cylinder for a period of 25 years from the date of purchase against faulty material or manufacture provided that :

- (a) It has been installed by a competent person in accordance with this installation manual and all current regulations and codes of practice at the time of installation.
- (b) It has been used solely for the purpose of heating potable water that complies with current (at the time of installation) EU standards and is not fed with water from a private source.
- (c) It has not been modified in any way.
- (d) It has not been subjected to excessive pressure or electrolytic action from dissimilar materials, or attack from any salt deposits.
- (e) It has been installed indoors in a frost-free environment.
- (f) The warranty card is completed and returned to Ferroli within 30 days of installation.

This warranty is not transferable. This warranty does not include claims due to frost or lime scale damage. Proof of purchase will be required against any claim. This guarantee does not affect your statutory rights.

Ferroli: Lichfield Road, Branston Industrial Estate, Burton-Upon-Trent, Staffordshire, DE143HD. Tel (08707) 272755 Fax (08707) 272766 – Website: www.ferrolicommercial.com

14. Installation, Commissioning and Service Record

CUSTOMER DETAILS			
NAME			
ADDRESS			
	TEL No.		

INSTALLER DETAILS			
COMPANY NAME		DATE	
ADDRESS			
	TEL No.		
INSTALLER NAME		REGISTRATION No.	

COMMISSIONING ENGINEER (IF DIFFERENT)			
COMPANY NAME		DATE	
ADDRESS			
	TEL No.		
INSTALLER NAME		REGISTRATION No.	

CYLINDER DETAILS		
MODEL		
CAPACITY	LITRES	SERIAL NO.

SERVICE RECORD DETAILS
Before completing the appropriate Service Interval Record below, please ensure you have carried out the service as described in the manufacturer's instructions and in compliance with all relevant codes of practice. It is recommended that your hot water system is serviced regularly and that your service engineer completes the appropriate Service Interval Record below.

SERVICE 1 DATE:
ENGINEER/COMPANY
TEL NO.
COMMENTS
SIGNATURE

SERVICE 2 DATE:
ENGINEER/COMPANY
TEL NO.
COMMENTS
SIGNATURE

SERVICE 3 DATE:
ENGINEER/COMPANY
TEL NO.
COMMENTS
SIGNATURE

SERVICE 4 DATE:
ENGINEER/COMPANY
TEL NO.
COMMENTS
SIGNATURE

SERVICE 5 DATE:
ENGINEER/COMPANY
TEL NO.
COMMENTS
SIGNATURE

SERVICE 6 DATE:
ENGINEER/COMPANY
TEL NO.
COMMENTS
SIGNATURE

SERVICE 7 DATE:
ENGINEER/COMPANY
TEL NO.
COMMENTS
SIGNATURE

SERVICE 8 DATE:
ENGINEER/COMPANY
TEL NO.
COMMENTS
SIGNATURE

SERVICE 9 DATE:
ENGINEER/COMPANY
TEL NO.
COMMENTS
SIGNATURE

SERVICE 10 DATE:
ENGINEER/COMPANY
TEL NO.
COMMENTS
SIGNATURE