

STERLING OF

Open Flue
Combination Boiler

GAS SAFETY (INSTALLATION AND USE) REGULATIONS.

It is the law that all gas appliances are installed by a competent person
in accordance with the above regulations

(For use on natural gas only. G20)

G.C. No

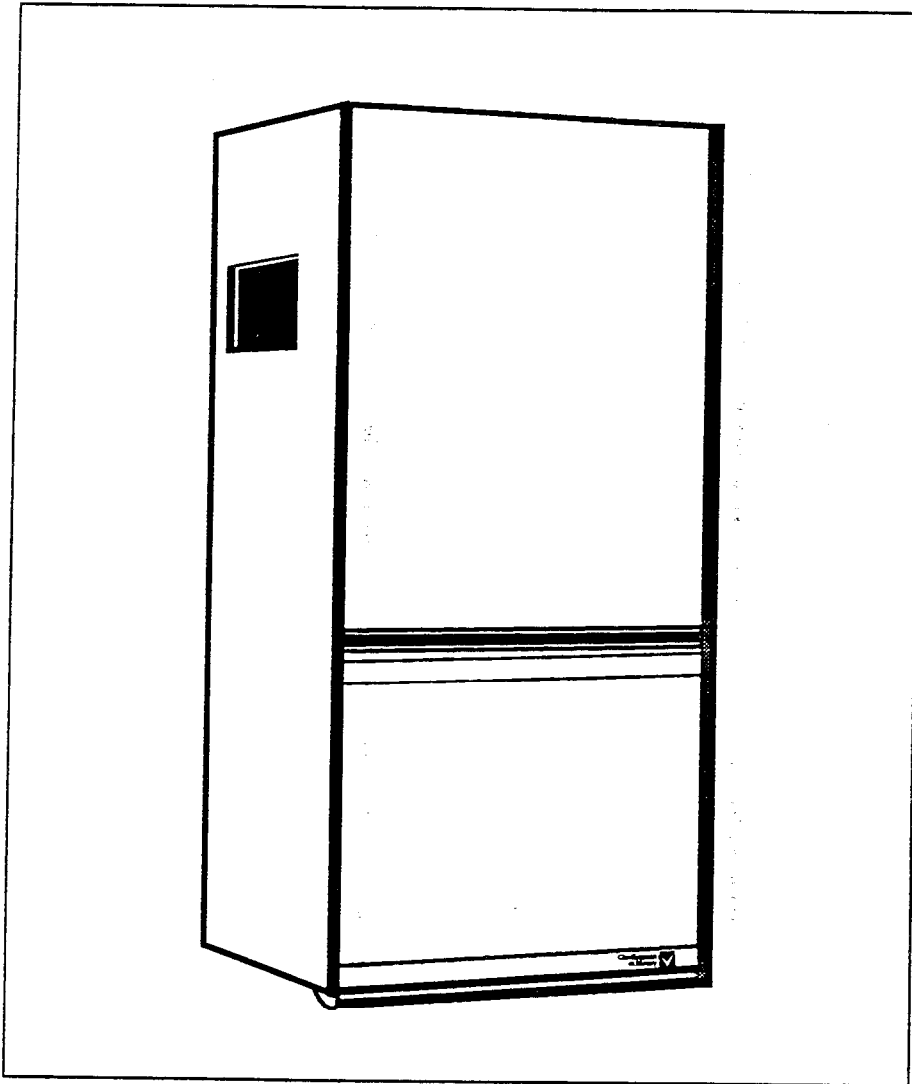

Installation and Servicing Instructions

(leave these instructions with the user)

**Chaffoteaux
et Maury**



Looking Good.Heating Better

CONTROL OF SUBSTANCES HARMFUL TO HEALTH

IMPORTANT

To comply with the Control of Substances Harmful to Health Regulation 1988 we are required to provide information on the following substance that is contained in this appliance.

Description Combustion Chamber Lining

Material Alumino Silicone Fibre

Precautions During servicing, keep the dust generation to a minimum and avoid inhaling any dust and contact with the skin and eyes. Normal handling and use will not present any discomfort, although some people with a history of skin complaints may be susceptible to irritation.

When disposing of the lining ensure that it is securely wrapped and wash hands after contact.

The STERLING OF is a wall mounted, low water content open flue appliance suitable for central heating and hot water via a non storage water to water heat exchanger. The maximum output is 23 kW (78480 Btu/h).

The boiler is designed for sealed systems only and included in the appliance is the expansion vessel, circulating pump, temperature and pressure gauges, safety valve, electric connection box, domestic expansion vessel and time clock.

1) The STERLING OF incorporates an integral draught diverter with a flue spigot size of 130 mm. It is design for a nominal 127 mm (5 in) flue to BS715

Special features includ :

- Output to central heating fully range rated between 1/3 and full output.
- High efficiency.
- Special jig plate enabling all pipework to be

installed before installing appliance.

- Independent control over central heating flow temperature and hot water.
- Fully adjustable central heating flow temperature.
- regulation between 48° C and 82° C.
- High limit thermostat for both boiler and hot water.
- Suitable for showers with compatible mixer valves.

Guarantee

The manufacturer's guarantee on this appliance is for 12 months from the date of purchase. The guarantee is void, if the appliance is not installed in accordance with the recommendations made herein.

1.1 DIMENSIONS

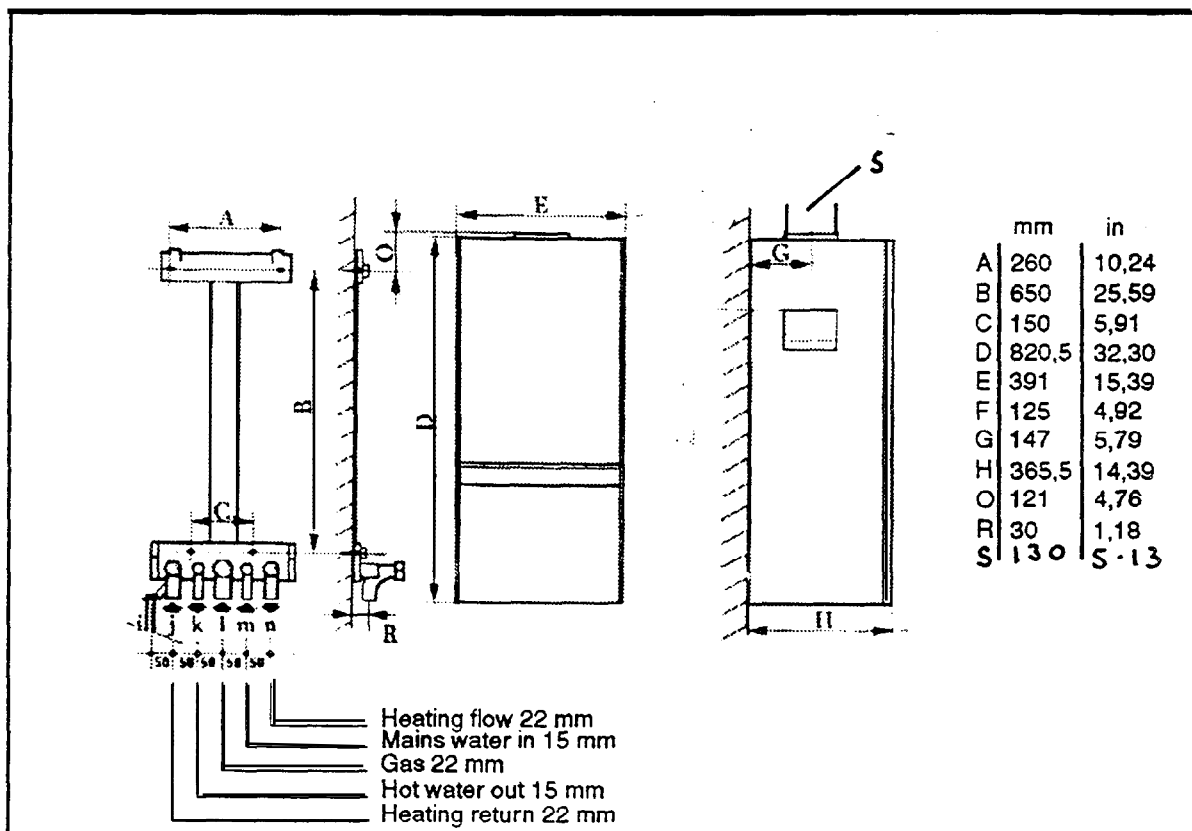

1.2 Technical Data

Hot water			Connections		
Input.....	28.90 kW	98612 Btu/h	Gas.....	22 mm copper	
Output.....	23.25 kW	79333 Btu/h	Heating flow.....	22 mm copper	
Water flow raised			Heating return.....	22 mm copper	
45 °C (81 °F)	7.4 l/min	1.7 gal/min	Mains cold water inlet.....	15 mm copper	
Water flow raised			Hot water outlet	15 mm copper	
35 °C (63 °F)	9.5 l/min	2.1 gal/min	Electrical supply 240 V ~ 50 Hz, fused at 3A.		
Water flow raised			Electrical consumption.....	195 watts	
30 °C (54 °F)	11.1 l/min	2.5 gal/min	Internally fused, two at 2A (BS 4265)		
Maximum temperature.....	60 °C	140 °F	Weight	42 kg	92.4 lb
Maximum pressure.....	10 bar	150 psi	Water capacity.....	4 litres	7 pints
Minimum working pressure.....	.6 bar	9 psi	Ignition - Piezo		
Gas rate.....	2.743 m ³ /h	96.87 ft ³ /h	Electrode - Chaffoteaux et Maury Ltd, spark gap 5 mm		
Burner pressure.....	11.8 mbar	4.7 in wg	Thermistor - SIEMENS		
Central heating			Boiler limit thermostat - Sopac (85°C)		
Maximum input.....	28.90 kW	98612 Btu/h	Hot water limit thermostat - Sopac (57°C ± 3°C)		
Maximum output.....	23.25 kW	79333 Btu/h	Safety overheat thermostat Tokoswitch - (105°C)		
Gas rate (maximum).....	2.743 m ³ /h	96.87 ft ³ /h	Gas valve - AEMF		
Burner pressure.....	11.8 mbar	4.7 in wg	Pump head - Grundfos UP 15/50		
Minimum input.....	10.85 kW	37022 Btu/h	Domestic expansion vessel initial charge pressure - 2 bar		
Minimum output.....	7.64 kW	26069 Btu/h	(30 psi)		
Gas rate (minimum).....	1.0 m ³ /h	35.31 ft ³ /h			
Burner pressure.....	1.5 mbar	0.6 in wg			
Minimum flow rate	300 l/h	1.1 gal/min			
Maximum pressure.....	3.0 bar	44 psi			
Natural gas					
Manifold injectors 14 of.....	1.28 mm	0.05 in			
Gas section restrictors 2/3 valves	4.4 mm	0.17 in			
1/3 valve.....	2.3 mm	0.09 in			

1.3

Minimum clearances around Boiler

Top.....	50 mm (2 in)
Bottom below case.....	150 mm (6 in)
Sides.....	150 mm (6 in)
Front.....	600 mm (24 in)

1.5 Description

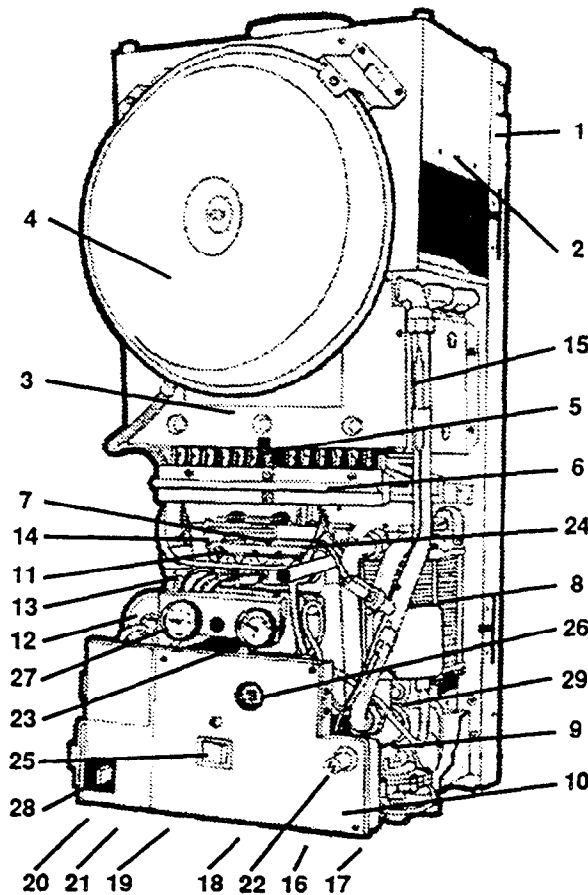

Fig. 4

The appliance is mounted in a steel case which has a white epoxy resin paint finish.

1. Chassis:

The chassis is a rigid plated mild steel pressing on which all components are mounted.

2. Draught diverter:

Made of coated steel.

3. Heating body comprising :

Copper finned tube heat exchanger protected with silicone resin paint. Combustion chamber in aluminium coated steel. Combustion chamber lining - ceramic fibre panels.

4. Expansion vessel:

The expansion vessel is mounted in front of the draught diverter. It has a capacity of 5,4 litres (1,19 gal) and is sized for a normal system water content where the head is equivalent to the maximum output of the boiler. The charge pressure is 0,65 bar.

5. The permanent pilot security is by thermocouple flame failure. (not illustrated).

6. Multigas burner comprising: stainless steel blades (14) and a manifold with injectors (14).

7. Gas section including thermoelectric valve two stage

solenoid valves.

8. Secondary heat exchanger :

The secondary heat exchanger is a plate type heat exchanger. A thermostat is fitted on the pipework limiting the domestic hot water temperature to a maximum of 57 ±3° C.

9. Change over valve :

The valve is activated by a demand for domestic hot water, closes the heating circuits, and directs water to the secondary heat exchanger.

10. Electrical box containing :

Mains connection

Fuses

Printed circuit boards

Connections for external controls

Connections for pump

Connections for change over valve and for gas solenoid valve

11. Solenoid valve :

Block on which 4 valves are mounted :

1/3 valve - 1st stage valve - heating and hot water (blue)

2/3 valve - full output to hot water (black)

2/3 valve - (variable valve) central heating (orange)

Thermoelectric valve.

12. Grundfos pump motor

13. Air separator and vent directly connected to the pump inlet (not illustrated).

14. Regulation screw to adjust output to heating (2/3 valve).

15. High limit thermostat.

16. Water service tap (not illustrated).

17. Flow Isolating valve - heating (not illustrated).

18. Gas service tap (not illustrated).

19. Domestic hot water outlet with regulator (not illustrated).

20. Safety valve with drain tap (not illustrated).

21. Heating return isolating valve with filter (not illustrated).

22. Ignition button for pilot light.

23. Thermometer indicating boiler flow temperature.

24. Push button for piezo ignitor.

25. Selector switch - hot water only/OFF/heating and hot water.

26. Adjustment to regulate heating flow temperature.

27. Pressure gauge.

28. Fuses holder.

29. Sanitary expansion vessel (not illustrated).

1.5 Description of Operation

1.5.1 The STERLING OF is combination boiler providing central heating and hot water. Hot water is provided on a demand basis. For the duration of the demand for hot water the central heating is interrupted. The appliance operates in two modes. A hot water only setting where it operates only on hot water demand and a hot water + central heating setting providing central heating and switching to hot water on demand.

1.5.2 Central Heating (see fig. 5)

The pump (13) circulates water which returns to the boiler via the return valve which incorporates a filter. Before reaching the pump it passes through an air separator and air purger (17). The return water passes through the heat exchanger (26) where it is heated. It then passes through the change over valve (14) which in heating mode is in its rest position and out via the flow valve to the radiator circuits.

An expansion vessel (30) is fitted in the primary circuit.

Temperature control is by means of a temperature sensing thermistor (11) and potentiometer. These signals are fed to a comparator.

When the flow approaches the set temperature, the variable gas valve is closed and the boiler continues to fire on 1/3 solenoid valve (8). When the set temperature is reached, the boiler switches off. If flow temperature reduces, the 1/3 solenoid valve opens followed by the variable solenoid valve (7).

Temperature adjustment is between a minimum of 40°C approx. and a nominal maximum of 82°C.

The boiler is protected by high limit thermostats (2) the operation of which interrupts the electrical supply to the magnetic valve and extinguishes the pilot and the burner.

1.5.3 Hot Water (see fig. 6)

When there is a demand water flows in from the cold mains supply through the water section part (16 and 15) of the change over valve (14). The inclusion of a venturi (16) produces high pressure under the diaphragm causing it to rise. This movement is transmitted to the change over valve closing the heating port and opening the hot water port, as shown. The primary water heated by the boiler now passes through the water to water heat exchanger (26) where it flows through alternate plates indirectly heating the DHW.

The rising of the change over valve spindle causes :

1. The opening of a microswitch stopping the pump. This circuit is remade by a second microswitch making when the hot water port is fully open.

2. The by-passing of the boiler thermistor brings the boiler under control of a fixed temperature thermostat (18) which operates on the 2/3 fixed solenoid (9).

The D.H.W. flow rate is adjustable by a restrictor (19) and a limiting thermostat (18) reduces the gas rate when the domestic hot water reaches 57°C by interrupting the electrical supply to the hot water solenoid (9).

If the primary circuit reaches 85°C the limit thermostat (20) closes 1/3 solenoid valves.

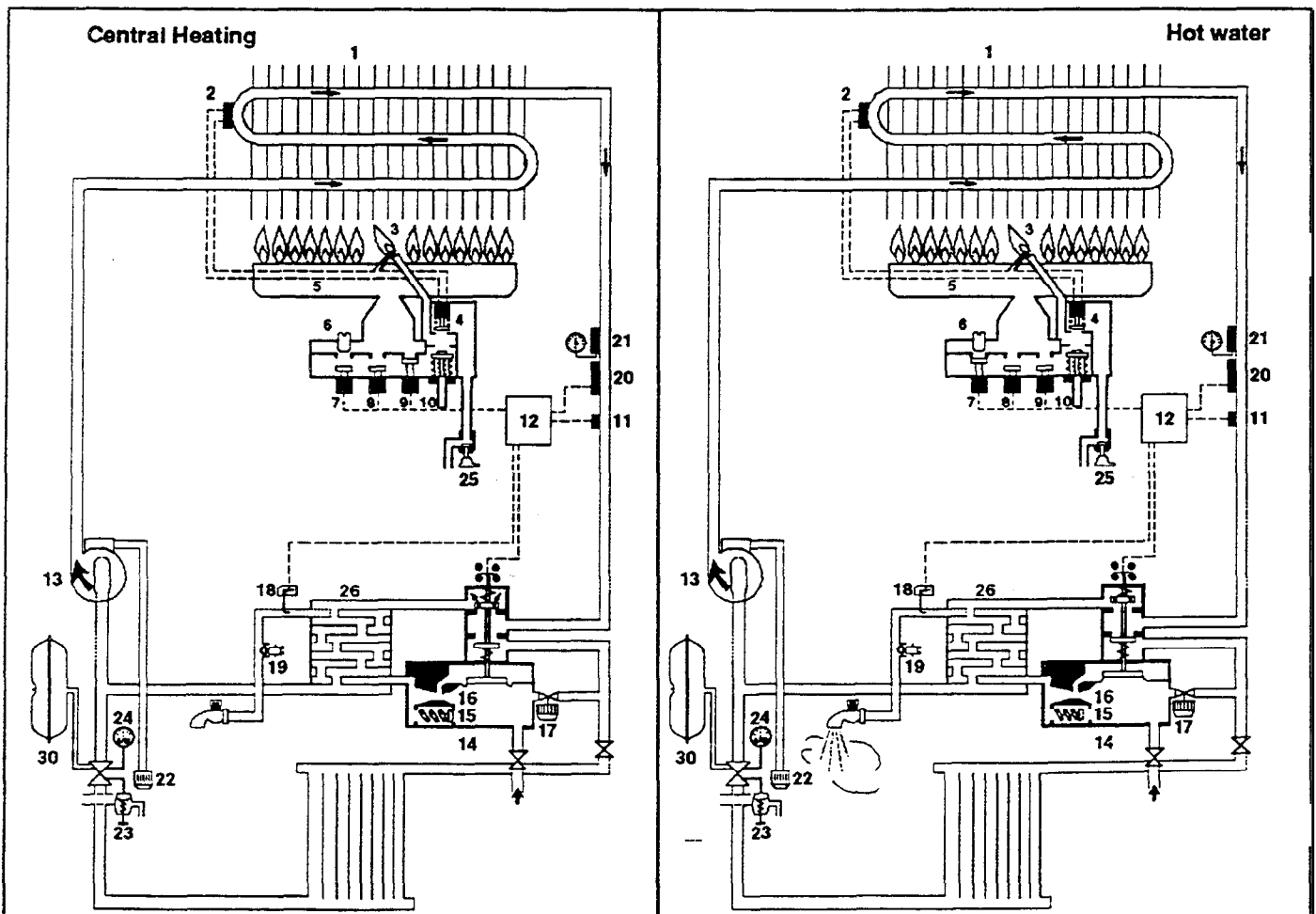

1.5.4 Gas (see figs. 5 and 6)

When the main gas tap (25) is turned to the on position gas is admitted to the gas section. Pressing the ignitor button (10) manually opens the thermo-electric valve (4) and allows gas to pass to the pilot assembly. When the piezo ignition button is pressed, a spark is generated at the electrode and lights the pilot (3).

After waiting 5 seconds there is sufficient energy being produced by the thermocouple for the thermoelectric valve (4) to be retained in the open position.

There are 3 solenoid valves the center blue valve (8)

fixed at 1/3 of max rated output, the right hand hot water (black) valve (9) fixed at 2/3 of maximum rated output, the left hand central heating (orange) valve (7) which is variable up to 2/3 maximum rated output.

The gas admitted by the orange valve is varied by adjuster (6) (see section 6.4).

1.5.5

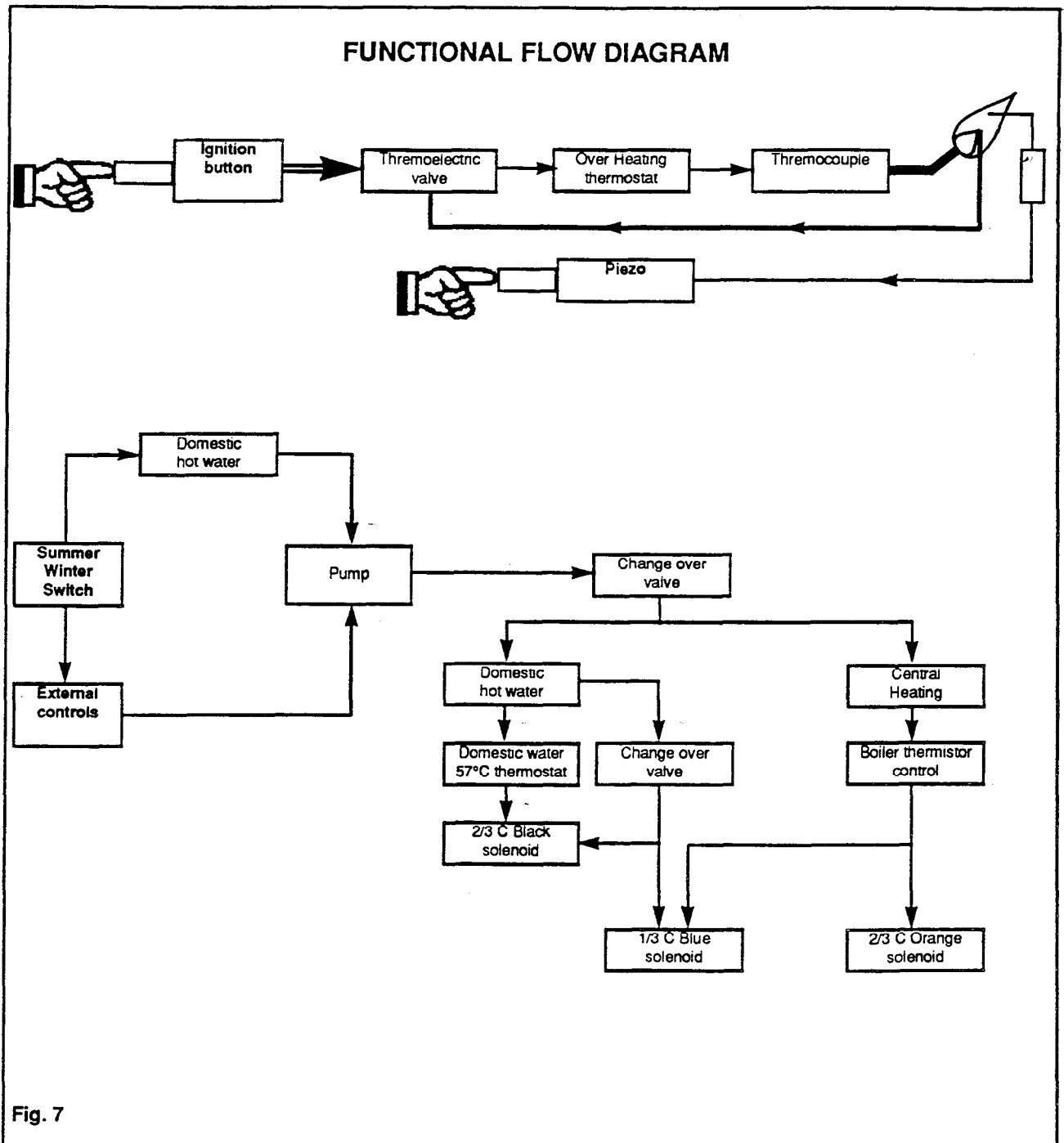

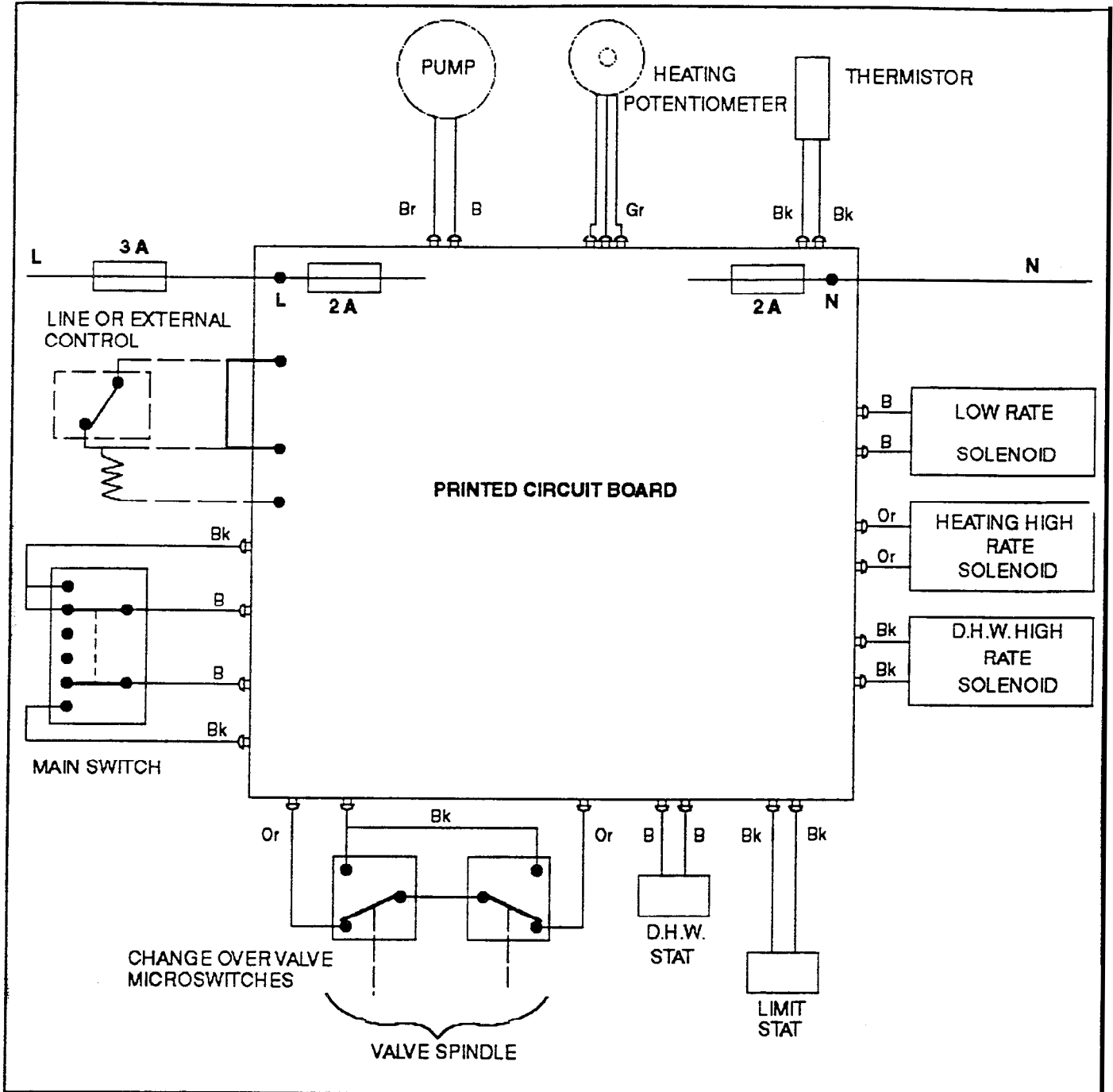

FUNCTIONAL FLOW WIRING DIAGRAM

OR	ORANGE
B	BLUE
BK	BLACK
BR	BROWN
R	RED
V	VIOLET
W	WHITE
GR	GREY

95 205 590

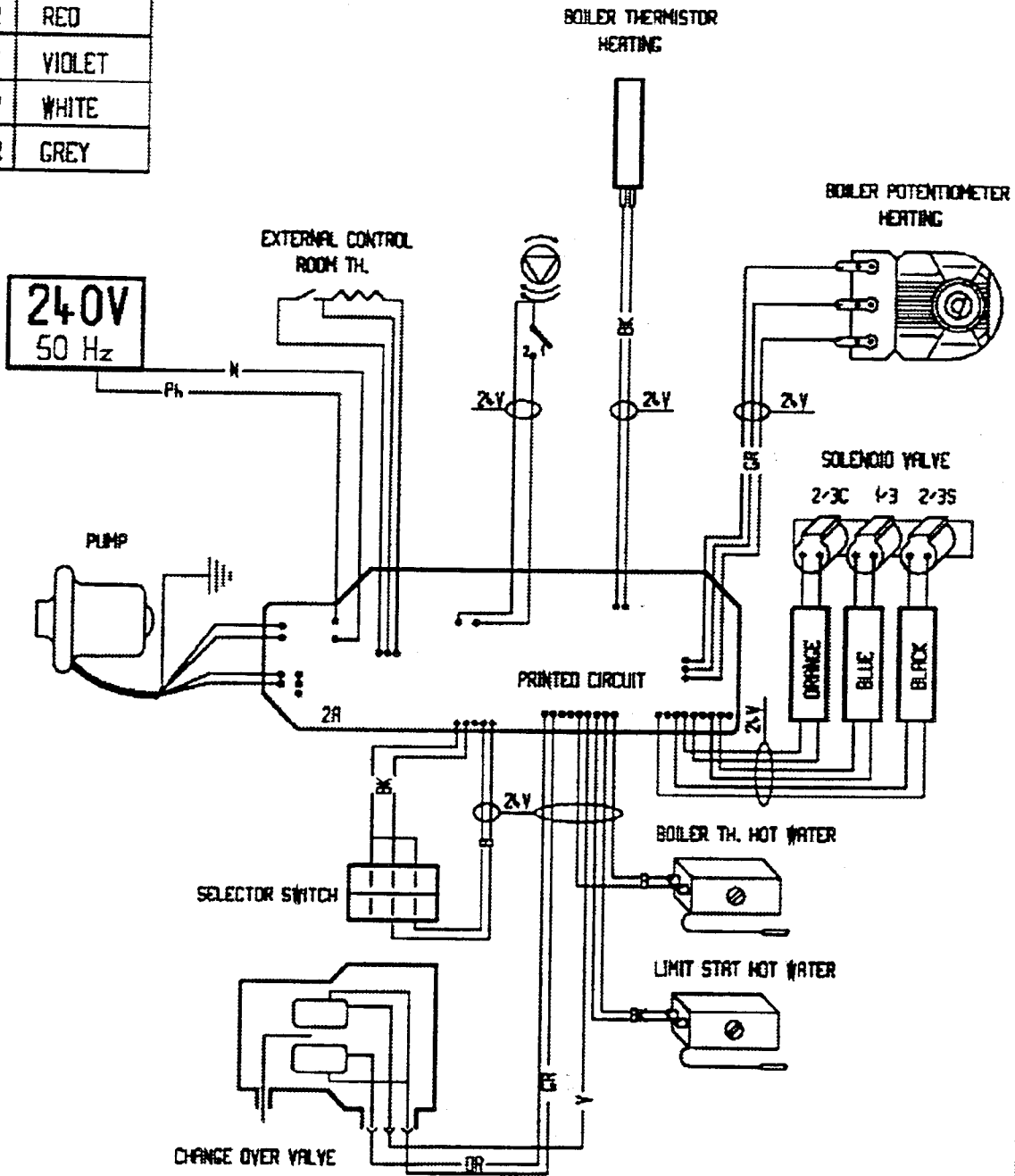

ALL CABLES ARE 240V EXCEPT WHERE THEY ARE INDICATED 24V

ILLUSTRATED WIRING DIAGRAM

Fig. 9

2 INSTALLATION REQUIREMENTS

2.1 General

The installation of the boiler must be in accordance with Gas Safety (Installation and Use) Regulations, Building Regulations, current I.E.E. Wiring Regulations and the Byelaws of the Local Water Undertaking. It should be in accordance also with the BS Codes of Practice and the British Gas Specifications for Domestic Wet Central Heating Systems and any relevant requirements of the local Gas Region and Local Authority Building Standards (Scotland) Regulations.

Detailed recommendations are stated in the following British Standard Codes of Practice:

B.S. 689I, B.S. 6798, B.S. 5440 : 1 and 2, B.S. 5449: I, B.S. 7593, BS 5546 B.G.DM2, B.S. 4814, B.S. 7074 1 e 2.

Note : Gas Safety Installation and Use Reg. It is the law that all gas appliances are installed by competent persons in accordance with the above regulations. Failure to install appliances correctly could lead to prosecution. It is in your own interest and that of safety to ensure compliance with the law.

2.2 Location

The boiler is not suitable for external installation. The position chosen for the boiler must permit the provision of a satisfactory flue termination. The location must also permit adequate space for servicing and air circulation around the boiler. The surface on which the boiler is mounted must be of non combustible material.

Where the installation of the boiler will be in an unusual location special procedures may be necessary and BS 5546 gives detailed guidance on this aspect.

A compartment used to enclose the boiler must be designed and constructed specifically for this purpose. An existing cupboard or compartment may be used provided that it is modified for the purpose. Details of essential features of cupboard/compartment design are given in BS 6798.

2.3 Water Circulation System

The STERLING FF is suitable for SEALED SYSTEMS ONLY and should be installed in accordance with the relevant recommendations given in BS 6798, BS 5449:1 (for the smallbore

or/and microbore systems) and the British Gas Specifications for Central Heating Systems.

2.31 Air supply

Room air supply

Where a boiler is to be installed in a room or internal space, the boiler requires the room or internal space containing it to have a permanent air vent. This vent must be either direct to outside air or to an adjacent room or internal space which must itself have a permanent air vent of at least the same size direct to outside air.

The minimum effective area of the permanent air vent(s) is related to the maximum rated input of the boiler and should be not less than: 101 cm² or 16 in²

2.32 Compartment air supply

If an open flued boiler is installed in a cupboard compartment permanent air vents are required in accordance with the following table. Note that both air vents must communicate with the same room or internal space and must both be on the same wall to outside air.

When cupboard or compartment vents communicate with a room or internal space the room or internal space must itself have a permanent air vent(s) as specified in BS5440 pt2.

An open flued appliance must not be installed in a room containing a bath or shower, bedroom or bedsitting room or in a compartment communicating with a bathroom, bedroom or bed sitting room. An open flued boiler must not be installed in a private garage.

Position of air vents	Air from room or internal space	Air direct from outside
High level	266 cm ² 41.2 sq. in	133 cm ² 20.5 sq. in
Low level	532 cm ² 82.5 sq. in	266 cm ² 41.2 sq. in

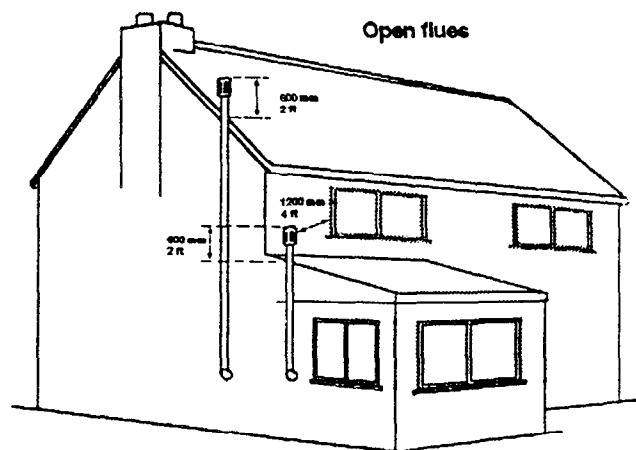

NO 1. Disturbed chimney flue with stainless steel flue
2. Existing chimney must be swept before using
3. All external flues should be insulated

Fig. 10

2.33 Effect of an extract fan

If there is any type of extract fan fitted in the premises there is the possibility that if adequate air inlet area from the outside is not provided, spillage of the products from the boiler flue could occur when the extract fan is operating. Where such installations occur a spillage test as detailed in BS5440:1 must be carried out and any necessary action taken.

2.4 Flue System

The boiler should be sited such that the maximum possible length of the flue system can be contained within the building and that the route of the flue rises continuously to the terminal and is as direct as practicable. The first 600 mm (2ft) of flue pipe should rise vertically from the draught diverter connection before the use of any bends or elbows.

Horizontal or shallow angle runs, right angled bends or mitred elbows should be avoided. Where an existing brick chimney is to be used it should be swept thoroughly before connection of the new boiler, and the chimney should be lined.

An approved British Gas terminal must be fitted and the terminal sited at the adjacent roof edge and, where possible, above the ridge line. The flue must not be terminated at or adjacent to a wall face. The cross sectional area of the flue must not be less than the area of the flue outlet serving the boiler. The point of termination must not be within 600 mm (2 ft) of an openable window, air vent or other ventilation opening.

Before installing the boiler to an existing flue system, the flue system must be checked by applying a smoke match to the opening at the base of the flue system. The flue pipe must not be closer than 25 mm (1 in) to combustible material. For twin walled flue pipe the 25 mm (1 in) distance is measured from the internal Pipe.

See fig. 2

2.5 Electrical Supply

- This appliance must be earthed.
- All wiring external to the appliance must conform to the current I.E.E. Regulations.
- The STERLING OF requires a 240 V - 50 Hz supply.
- Connection of the appliance and any system controls to the mains supply must be through a common isolator and must be fused at 3A maximum.

This should preferably be an unswitched shuttered socket outlet and 3 pin plug to BS 1363. Alternatively, a double pole isolating switch may be used, provided it has a minimum contact separation of 3 mm in both poles. The isolator should be clearly marked showing its purpose, preferably positioned close to the appliance.

-Fuse the supply at 3A.

-The supply cord must be 0.75 mm² (24 x 0.2 mm) three core to BS 6500 Table 16.

2.6 Gas supply

The STERLING OF requires 1,09 m³/h 38.67 ft³/h of natural gas. The meter and supply pipes must be capable of delivering this quantity of gas in addition to the demand from any other appliances in the house. The complete installation must be tested for soundness as describe in BS 6891.

3 SYSTEM GUIDANCE

3.1 General

The low water content STERLING OF boiler includes the expansion vessels, safety overheat thermostat and pressure gauge, and safety valve.

The flow temperature is adjustable and gives a nominal 82 °C (180° F) on its maximum setting.

Detailed recommendations for water circulation are given in BS 5546. Whilst the boiler provides hot water, there may be occasions when a cylinder will be used, for instance, if the property has two bathrooms. Detailed recommendations of this application are given in sections 3.13 to 3.16. Thermostatic control should be used in the heating circuits and the cylinder if one is fitted.

It must be remembered that a combination appliance has a limited volume of hot water that can be supplied at any one time for a given temperature. Indeed in most respects it is equivalent to a multipoint water heater and many of the constraints associated with multipoints apply equally to combination boilers.

The appliance has two separate functions, to provide heating and hot water on demand. It can have a third which is to supply hot water high demand through the use of an indirect cylinder, where there is more than one bathroom or if the standard and appointments of the property, such as basins in all bedrooms and a large kitchen indicate a high usage of hot water.

Hot water produced indirectly through a cylinder can be used to satisfy high simultaneous demand outlets -bathrooms etc, whilst the benefits of high efficiency in generally small quantities of hot water, can be fully utilised in kitchens, cloakrooms and so on.

Separate time and temperature control over hot water generated in this way can be achieved by the use either of two port valves or three port valves of a flow share or priority pattern.

It is also possible, where the occupation of the house is variable, to provide either for a small or large load. This is best achieved with a tall, small diameter cylinder. See section 5 for possible wiring arrangements.

A domestic expansion vessel is fitted to the boiler with a capacity of 0,16 litres, prior to the secondary heat exchanger which enables the boiler to be connected to a cold main water supply containing a non-return valve or any device containing a non-return valve.

IF THE MAINS COLD WATER SUPPLY IS IN EXCESS OF 10 BAR (150 PSI) A PRESSURE LIMITER MUST BE FITTED TO AVOID EXCESSIVE PRESSURE BEING APPLIED TO THE BOILER.

When replacing an existing cylinder storage system with STERLING OF it is essential that all redundant pipework is removed and dead legs eliminated,

In properties where there are multiple draw-off Points on different levels consideration should be given to the use of non-return valves in the secondary hot water system to avoid "active dead legs". No non- return valve should be less than 1 m (3 ft) above the top of the appliance and ideally should be as close as possible to the hot water outlet.

3.2 System controls

The boiler is electrically controlled and is suitable for most control schemes currently available including thermostatic radiator valves and motorised valves.

When using motorised valves the controls should be arranged to switch off the boiler when circuits are satisfied. The boiler requires a minimum flow rate of 300 L/h (1.1 gal/min) and consequently, if thermostatic radiator valves are fitted to all radiators, a by pass will be necessary. This will ensure that the boiler will operate correctly when all TRVs are closed. (see fig. 17).

3.3 Pump

The boiler is fitted with a Grundfos UP.15/60 pump head. The graph (fig. 11) indicates the residual head available for the system.

Fig. 11

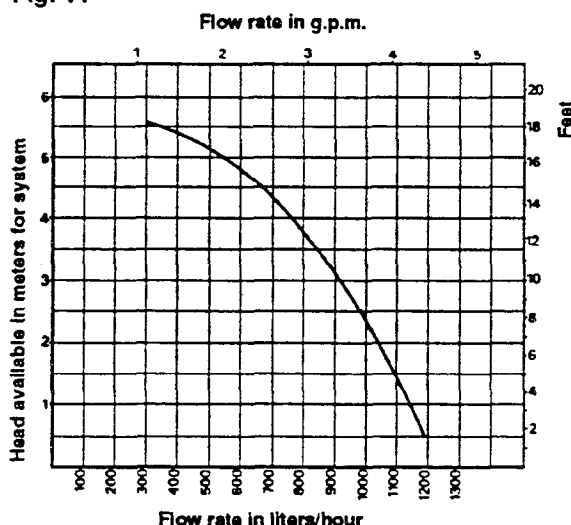

3.4 Expansion vessel

The expansion vessel which is fitted on the front of the combustion chamber accommodates system water expansion. The vessel has a capacity of 5.4 litres (1.19 gals) and is charged to a pressure of 0.65 bar (9.7 p.s.i.).

THE CONNECTION IN THE CENTRE OF THE EXPANSION VESSEL IS A CHARGING AND NOT

A VENT POINT.

At the design flow temperature and the initial system pressures quoted the maximum allowable system volume is 75 litres. If the water volume is not known and cannot be accurately assessed from manufacturers data the following volumes may be used to give a conservative estimate of the system volume.

Boiler	4 litres (0.8 gals)
Small bore pipework	0.3 litres (0.07 gals)
	per 0.292 kW
Microbore pipework	7 litres (1.5 gals)
Steel panel radiators	2.3 litres (0.5 gals)
	per 0.292 kW (1000 Btu/h) of system output
Hot water cylinder	2 litres (0.44 gals)

If the volume exceeds 75 litres an additional vessel will be required fitted in the flow from the appliances. Refer to BS 7074 Pt. 1 or BS 5449 for details of sizing.

3.5 Mains water connection

There shall be no permanent connection to the Heating System Pipework for filling or replenishing without the approval of the Local Water Authority (see Byelaw No.14 and figs. 12 and 13).

3.6 Filling point (see BS 6798: Appendix A)

Filling and recharging can be done :

- 1) Through a temporary hose connection from a draw off tap supplied from a service pipe under mains pressure provided that this is acceptable to the Local Water Authority, see fig. 12).
- 2) Through a self contained unit comprising a cistern, pressure pump if required and if necessary a pressure reducing valve or flow restrictor, fig. 13.
- 3) Through a cistern, used for no other purpose, permanently connected to a service pipe. The static head available must be sufficient to provide the designed initial system pressure.

3.7 Make up system

Provision must be made for replacing water lost from the system indicated by a reduction in pressure shown on the pressure gauge. Recharge through the filling point (see section 3.6).

3.8 Pipework

Pipework can be of copper or suitable plastic, small bore or microbore with capillary or compression jointing to a high standard, leak sealant must not be used in the system.

3.9 Domestic expansion vessel

The expansion vessel which is fitted on the cold water supply to the secondary heat exchanger accommodates domestic hot water expansion. The vessel has a capacity of 0.16 litres (0.035 gals) and is charged to a pressure of 2 bars (30 p.s.i.); it has maximum working pressure of 10 bars with a.. allowable pressure peak of 14 bars.

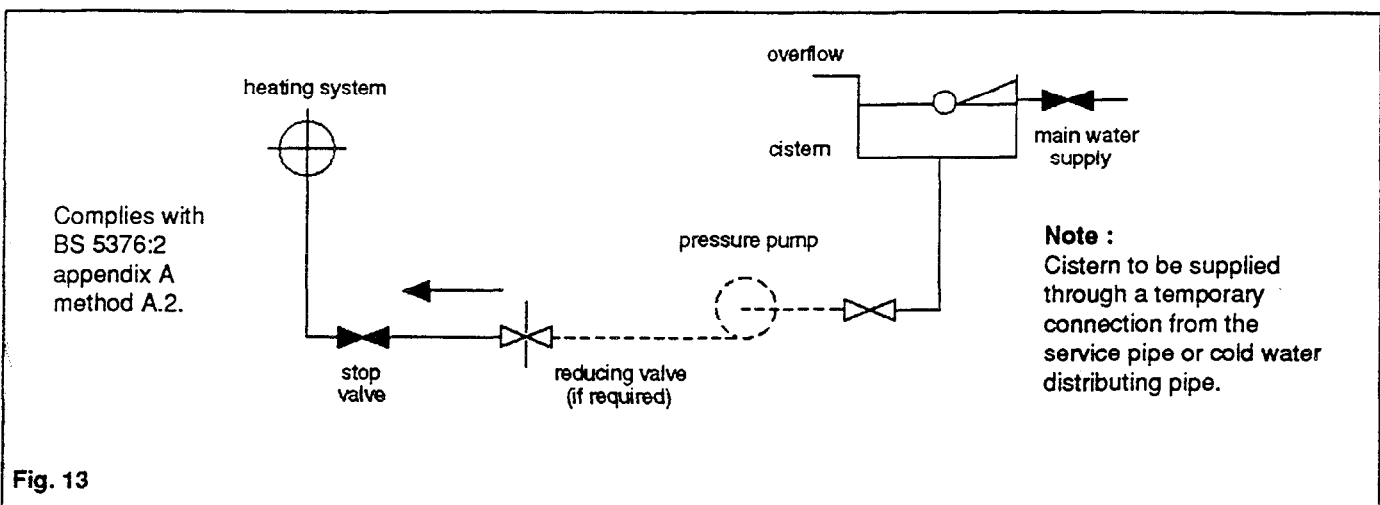
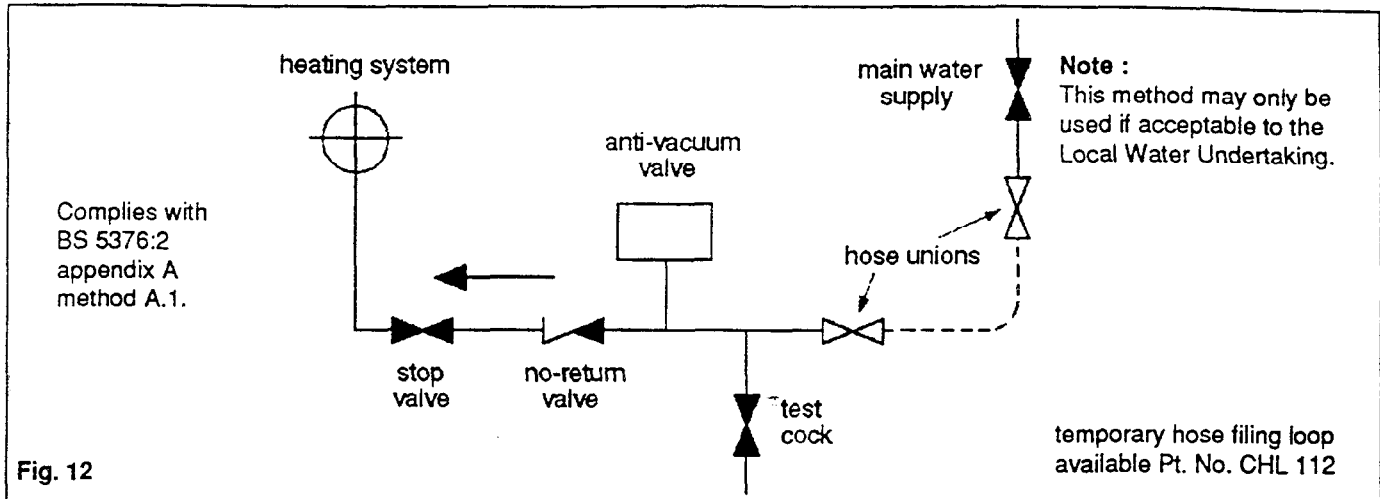

3.9.1 Boiler replacement (retrofit)

In an old system where the boiler is being replaced, we recommend the use of a strainer, fitted with a drain tap on the heating return, designed to retain scale particles and other solid debris. It is good practice to use a chemical cleaner with a flocculating agent, used as recommended by the cleanser manufacturer, to clean the system before the old boiler is removed. (see BS 7593).

3.9.2 Existing systems

Valves and joints should be carefully checked for leaks and the appropriate action should be taken either as a repair or replacement. The old open system has probably only been subjected to a pressure of 0.4 bar or less. When you change to a sealed system where the charge pressure will be 1.0 bar and the running pressure exceeding 1.5 bar, consideration should be given to the replacement of radiator valves with a pattern capable of sealing at the higher pressures.

3.10 Cylinder

Where a domestic hot water cylinder is used with the STERLING OF it MUST be of the indirect and high recovery type to BS 1566 Pt 1. Single feed cylinders are not suitable for use with this appliance. Flow and return pipework to the cylinder should be in 22 mm pipe.

3.11 Inhibitors and water conditioners (see BS 7593)

Chaffoteaux et Maury generally recommend the use of inhibitors in systems using the STERLING OF boiler.

The following are the appliance manufacturer's recommendations:

1) Use only a British Gas or similar approved inhibitor. These manufacturers can assist with the selection. Grace Dearbon Ltd - Widnes - Cheshire WA8 8 UD Tel: 051 424 5351.

Fernox Manufacturing Company Limited Britannica Works, Clavering, Essex CBI 1 4QZ Tel: 0799 085811.

2) Use only the quantities specified by the inhibitor manufacturer.

3) Cleanse the system as required by the inhibitor manufacturer.

4) Add inhibitor only after flushing when finally re-filling the system.

5) In-line water conditioners both of chemical and magnetic type are suitable for use with the STERLING OF.

3.12 Add-on devices

It is important that no external control devices e.g. economisers be directly fitted to this appliance unless covered by these installation instructions or agreed with the manufacturer in writing. Any direct connection of a control device not approved by the manufacturer could make the guarantee void and also infringe the Gas Safety (Installation & Use) Regulations.

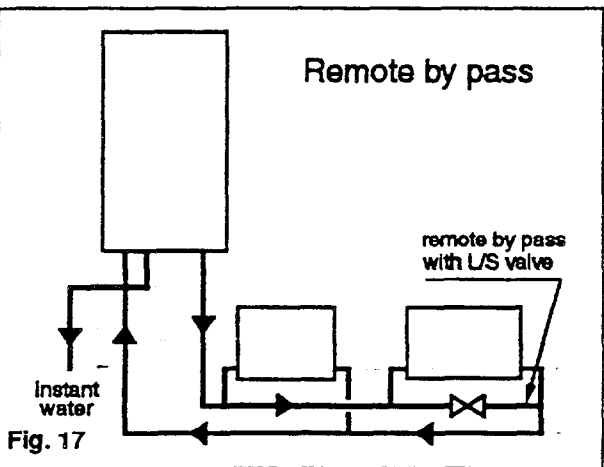
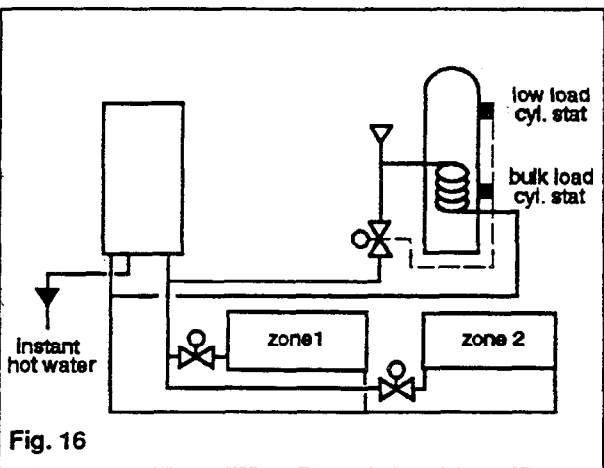
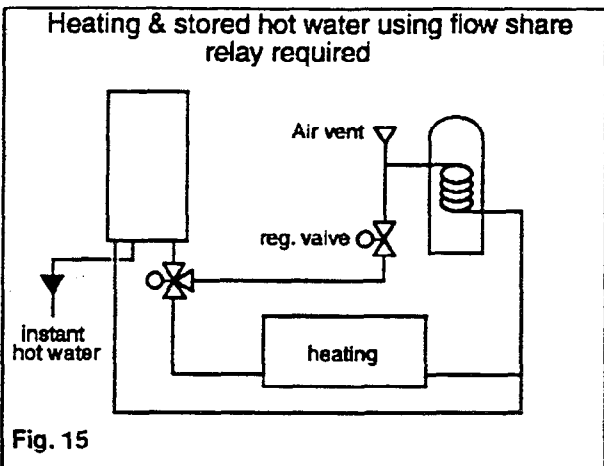
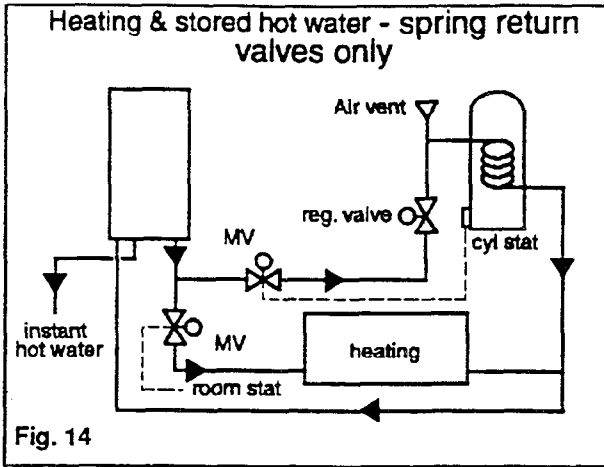

3.13 Heating and hot water systems

Figs. 14, 15, 16 and 17 indicate various layouts for the production of hot water. It is recommended that only a high recovery indirect cylinder is used and circumstances may from time to time dictate that a special saturated heat exchanger in an indirect cylinder may be desirable.

When replacing an existing cylinder storage system with an instantaneous type system it is essential that all redundant pipework is removed and dead legs eliminated.

The consideration of heating systems using thermostatic valves should ensure that the minimum flow rate through the appliance is maintained at all times and in this connection the remote by-pass is preferred (see fig. 17).

3.14 Shower Application

The appliance can be used to supply hot water to separate shower draw-off. It must not be used to supply more than one shower mixing valve.

The recommended pipework arrangement for a shower is shown below and the hot supply to the mixing valve should be the first draw off.

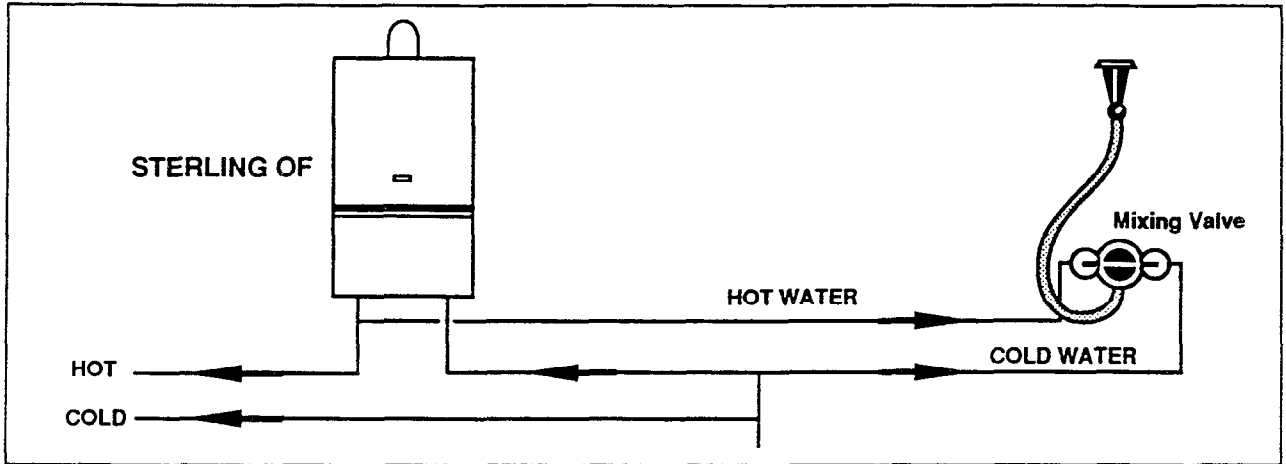

It is important to select a compatible shower for the STERLING OF. The following manufacturers can assist with the selection

New Team Ltd
Brunell Road
Earlstree Industrial Estate
Corby
Northants NN17 2LF

Tel.No.0536-62822

Meynell Valves Ltd
Shaw Road
Bushbury
Wolverhampton
West Midlands WV10 9LB

Tel.No.0902-28621

Aqualisa Products Ltd
Hortons Way
London Road
Westerham
Kent TN16 1BT

Tel.No.0959-63240

Barking Grohe
1 River Road
Barking
Essex IG11 0HD

Tel.No.081-594-8898

Do not use the appliance with push on hand showers that fit over hot and cold taps.

IMPRTANT

The STERLING OF must not be installed in a room containing a bath or shower or in a compartment communicating with a room containing a bath or shower.

4 INSTALLING THE BOILER

A vertical flat area is required for the boiler: 1122 mm high x 591 mm wide (44 in x 23.25 in). The surface on which the boiler is mounted must be of a non reverberating and of a non combustible material. The appliance is supplied in a single carton which contains :

- 1) The chassis with all functional parts attached.
- 2) Casing comprising : 2 side panels
1 front panel
1 controls fascia cover
1 glass door complete with hinges
- 3) Mounting bracket comprising : top support plate
spacing strip
bottom support plate
plastic jig plate connection
- 4) Plastic bag containing : gas filter/washer
- 5) Box containing : gas and water connections inc.4 above.
- 6) Box containing : control knobs
safety valve
wall plugs
screws and fixings.

4.1

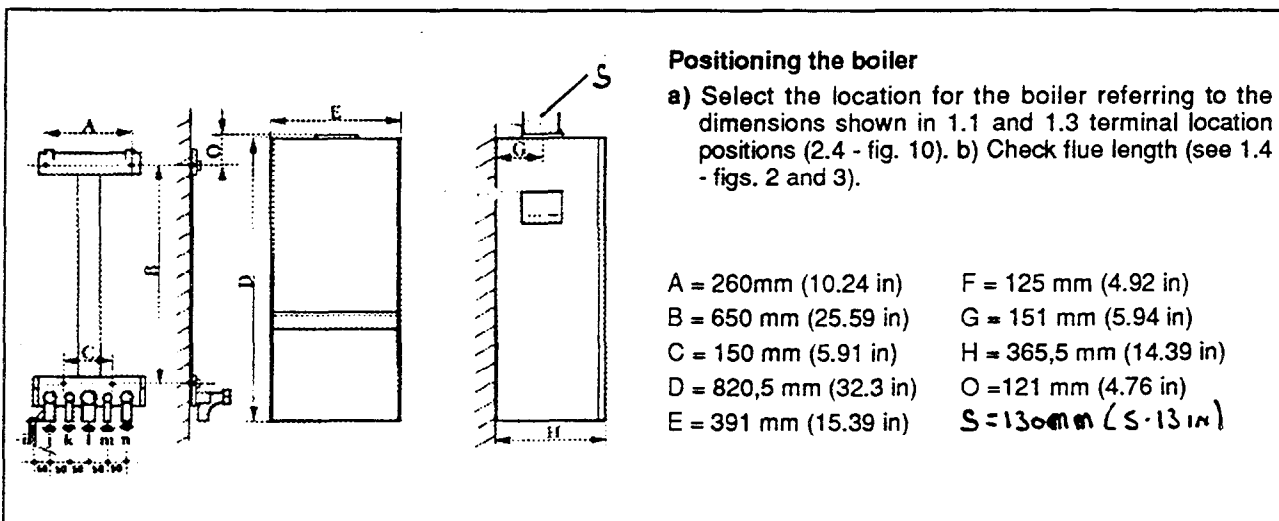

4.2

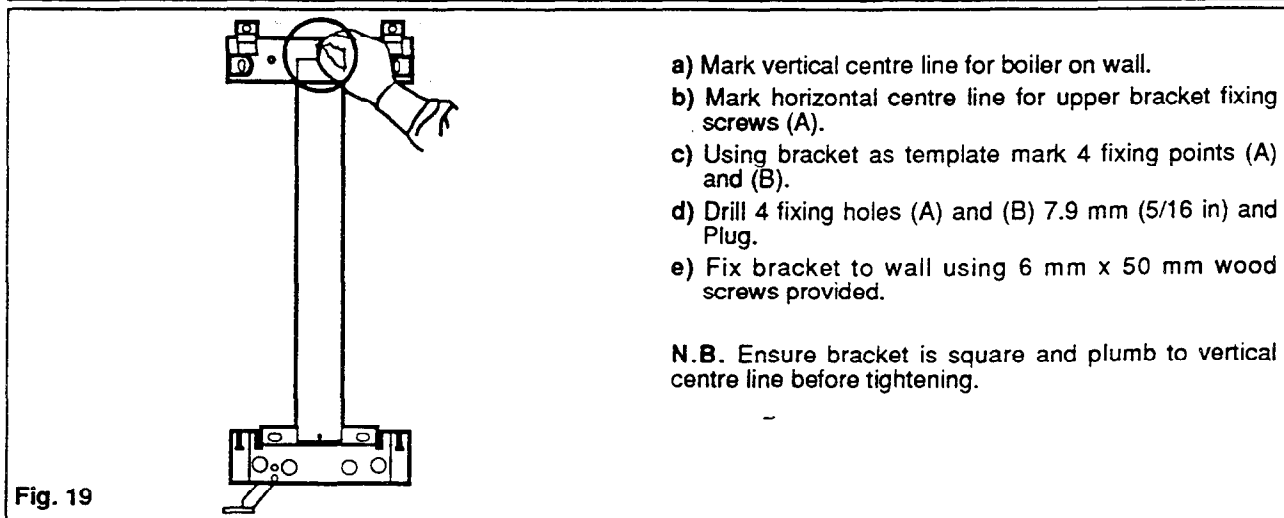

4.3

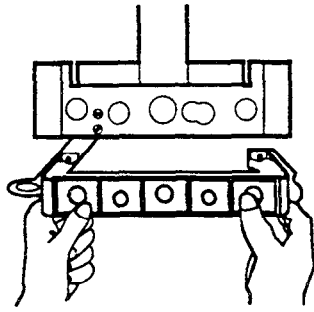

Jig plate

N.B. By using the plastic jig plate the piping system can be completed before the boiler is mounted.

- a) Attach plastic jig plate to bottom bracket using 4.6 mm x 10 hexagonal screws provided (fig. 21).
- b) Fit copper tails and washers to jig plate, the mains water inlet tail (M) is the shorter of the two 15 mm tails
- c) All connections can either come from above or below using the standard tails provided, with the exception of the gas which must enter from below.

4.4

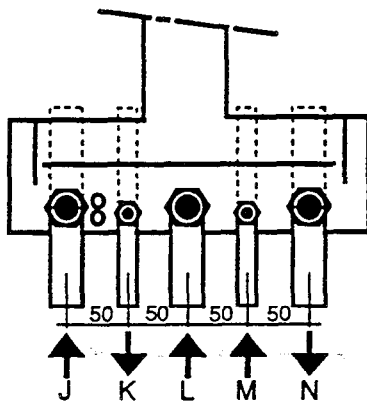

Fig. 22

Gas and water connections

Tube diameter

J) Heating return	22 mm
K) Hot water outlet domestic	15 mm
L) Gas inlet	22 mm
M) Mains water inlet domestic	15 mm
N) Heating flow	22 mm

Pipework

- a) Copper tails are 22 mm and 15 mm to accept straight connectors.

4.5

Water connections

- a) Make connections to copper tails using either solder capillary fittings or compression type.

4.6

Gas connection

- a) The gas connection is 22 mm diameter.
 - b) Make the gas connection using solder capillary fittings.
- N.B.** The gas supply pipe must not be less than 22 mm diameter

IMPORTANT NOTE :

At this stage the pipework can be completed and tested before the boiler is positioned. Having completed a satisfactory test on the pipework the boiler can now be fitted or retained for fitting at a later date.

4.8

Fitting the boiler

- a) Remove plastic jig plate from bracket and retain screws.
- b) Hang boiler on mounting bracket, ensure that it is properly located.

N.B. Insert washer into union nut and offer assembly to boiler. Use the plain black 3/4 and 1/2 diameter graphited fibre washers for water unions, and the white 3/4 filter/washer for the gas union.

- c) Connect water union using plain washers, working from left to right.
- d) Connect the gas union using the filter/washer packed separately either way round.

N.B. As an alternative to using the plastic jig plate the tails can be fitted to the boiler before mounting, then connected to the services.

4.9

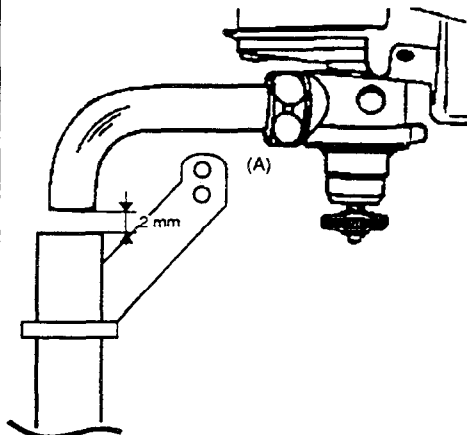

Fig. 24

c) Fit support bracket (A).

- d) Fit 14 mm tail drain bend using washer provided.

N.B. The drain must be 22 mm and the 14 mm drain bend from the safety valve must be installed so that discharge of water is readily visible. A tundish arrangement is acceptable. The connection must NOT be made by a capillary or compression fitting directly between the 14 mm drain bend and the 22 mm discharge pipe without an 2 mm air gap. see fig. 24.

The 22 mm discharge pipe must discharge to the outside of the building where possible over a drain. The discharge must be such that it will not be hazardous to occupants or cause damage to external electrical components or wiring. The pipe should be directed downwards. It must not discharge above an entrance or window or any type of public access as the temperature of the water being discharged may reach 100° C.

the heating

n the socket

grub screw

4.10

Connecting flue :

Flue pipe for STERLING OF : 125 mm

When the appliance is set lower than the maximum output for heating, the flue size must still be calculated on the maximum boiler output.

4.11

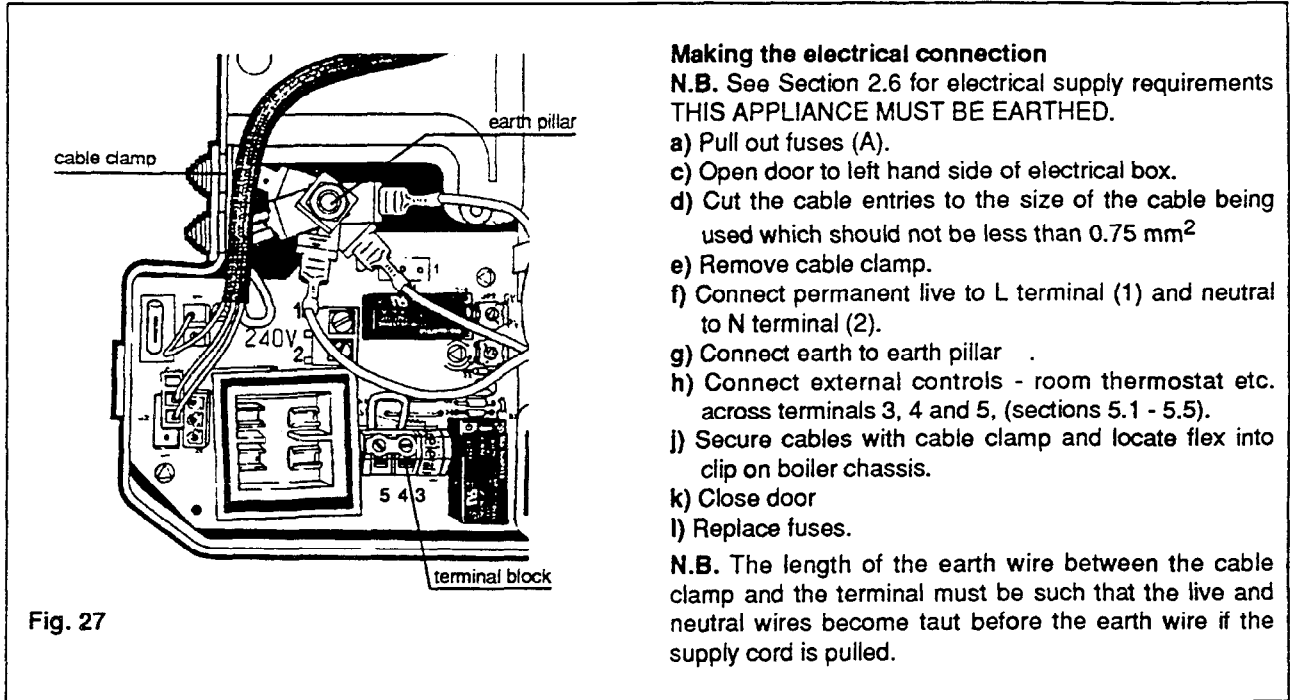

Fig. 27

Making the electrical connection

N.B. See Section 2.6 for electrical supply requirements
THIS APPLIANCE MUST BE EARTHED.

- a) Pull out fuses (A).
- c) Open door to left hand side of electrical box.
- d) Cut the cable entries to the size of the cable being used which should not be less than 0.75 mm²
- e) Remove cable clamp.
- f) Connect permanent live to L terminal (1) and neutral to N terminal (2).
- g) Connect earth to earth pillar .
- h) Connect external controls - room thermostat etc. across terminals 3, 4 and 5, (sections 5.1 - 5.5).
- j) Secure cables with cable clamp and locate flex into clip on boiler chassis.
- k) Close door
- l) Replace fuses.

N.B. The length of the earth wire between the cable clamp and the terminal must be such that the live and neutral wires become taut before the earth wire if the supply cord is pulled.

In the event of an electrical fault after installation preliminary electrical system checks must be carried out. Checks to ensure electrical safety should be carried out by a competent Person i.e earth continuity, polarity and resistance to earth .

Use only voltage free external control switching. No supply voltage should be connected to terminals 3, 4 or 5.

5. EXTERNAL CONTROLS

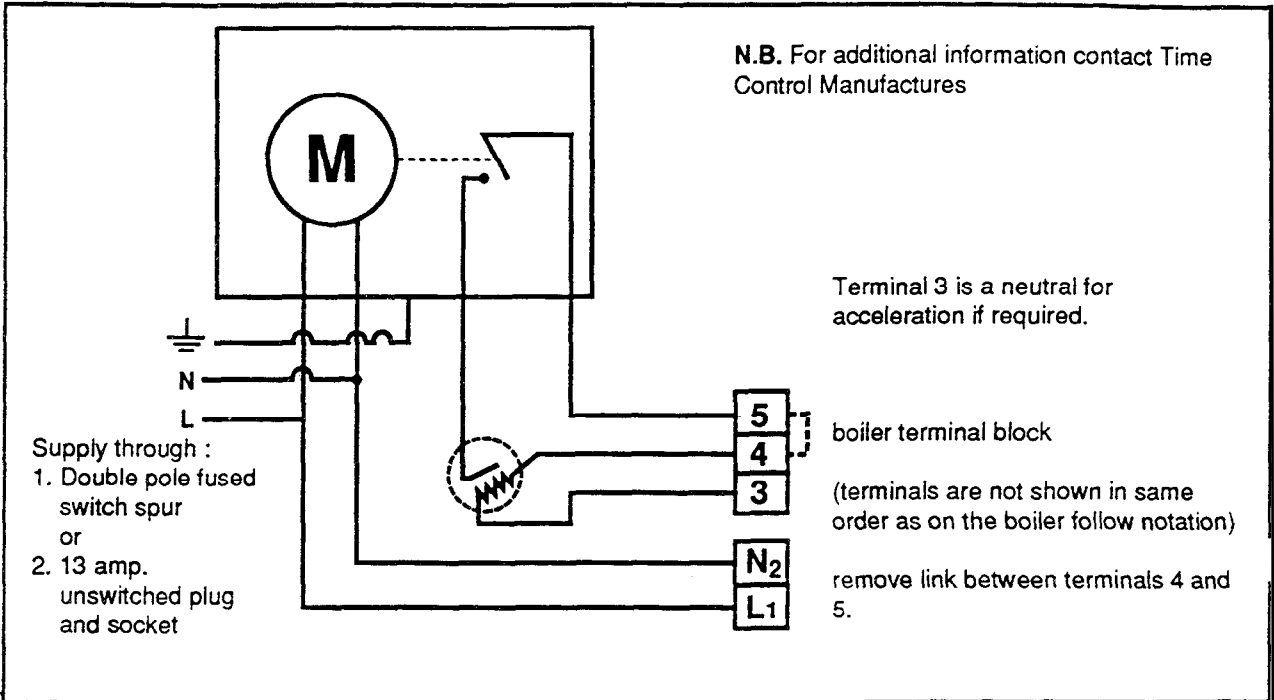

- 5.1 **Time clock - Time clock and room thermostat**
 - The time clock contacts **must** be voltage free (remove external links).
 The room stat accelerator should be connected if fitted.
 - Supply fuse valve 3 amp.

5.1 **Time clock and zone valves (spring return)**

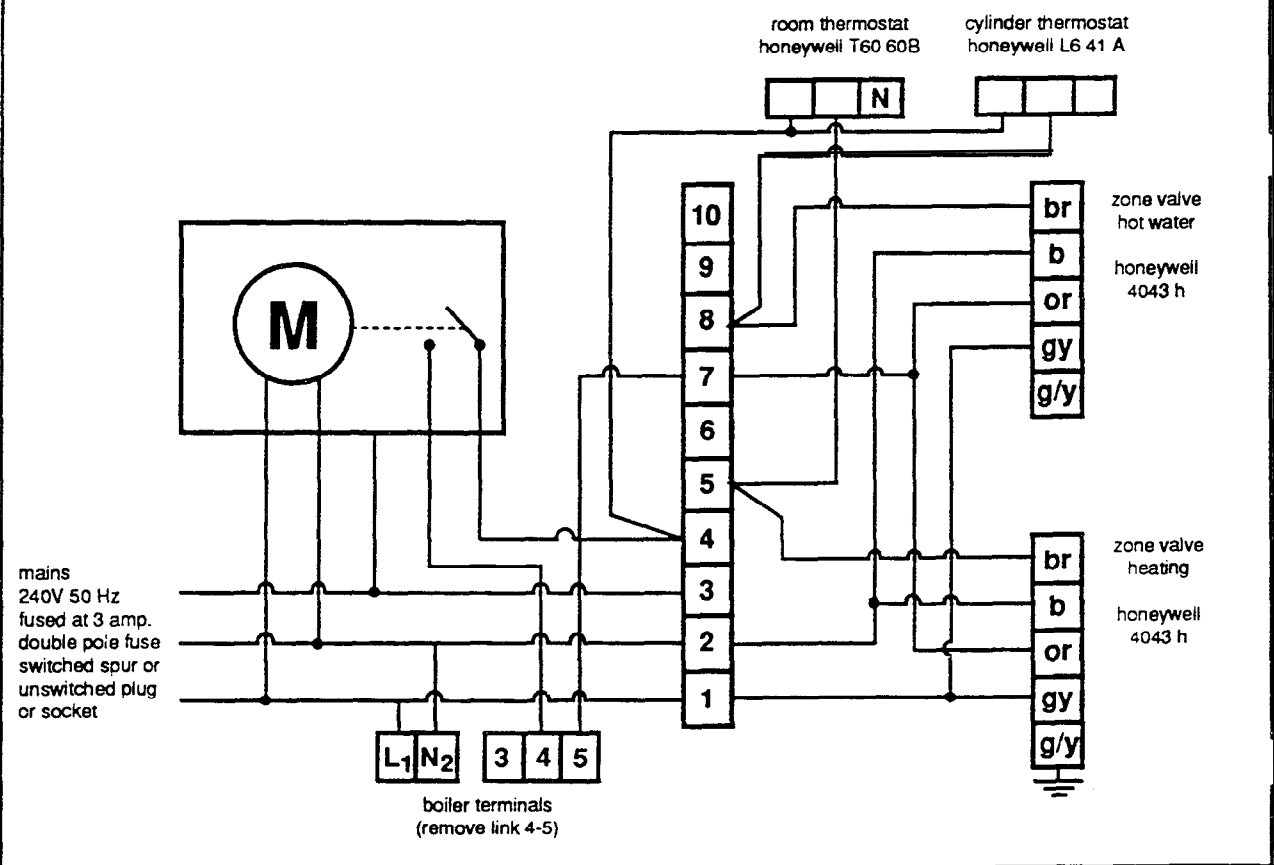

5.2

Programmer and zone valves

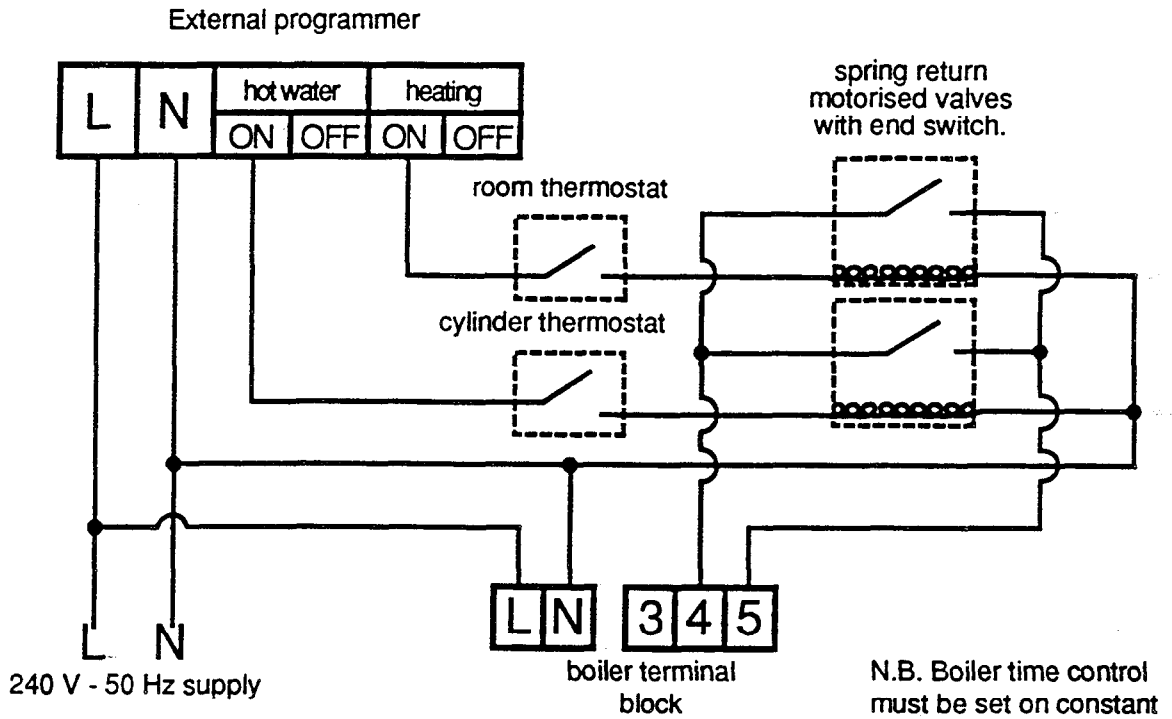

Fig. 30

5.3

Honeywell Y plan, Satchwell flow chart or Satchwell mini valves to control zones.

Refer to controls manufacturers literature. Live to relay coil is the wire in their literature which carries the signal to the boiler.

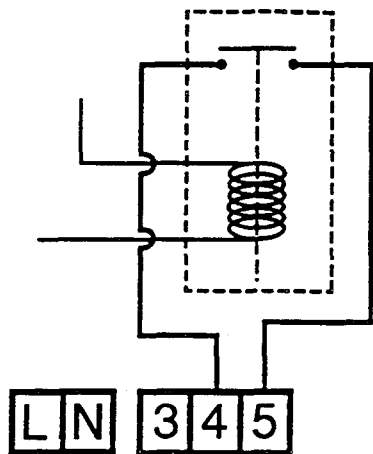

Fig. 31

5.4 Frost thermostat

It is advisable, if the appliance is fitted in a location subject to adverse weather conditions, to protect the system from frost damage by fitting an additional remote frost thermostat which will override the controls whilst the selector switch is set to hot water + central heating.

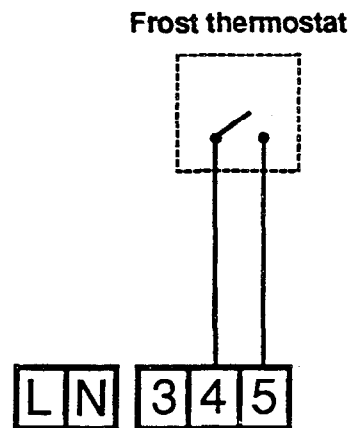

Fig. 32

6. COMMISSIONING

6.1

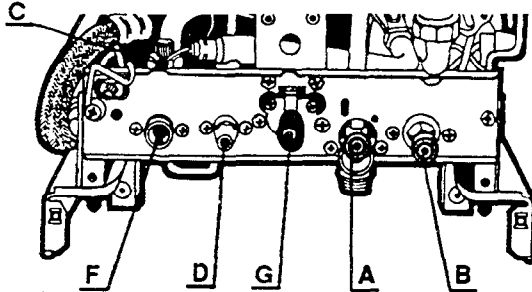

Fig. 33

Hot water circuits - filling

- 1) Check that stop cocks up stream of appliance are of a fixed jumper type.
- 2) Open mains cold water inlet valve (fig. 33) (A).
- 3) Vent installation by opening taps and closing.
- 4) Check that 'dead legs' have been eliminated.
- 5) Check for water soundness and rectify if necessary.
- 6) Set D.H.W. flow rate as required by adjusting screw (D) increase (anticlockwise) decrease (clockwise), see section 6.7.

6.2

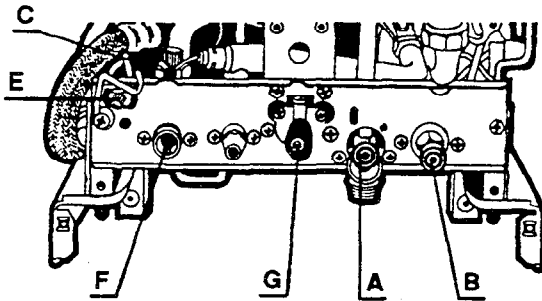

Fig. 34

Central heating circuits - filling

- 1) Ensure that the isolating valves are open (fig. 34 B and C). **N.B. Valve (C) must be turned anti-clockwise by the knurled nut until it dislocates from the thread and then pulled out horizontally to its extremity (approximately 30 mm (1 1/4 ins)).**
- 2) Fill system to charge condition, see section 3.
- 3) Vent radiators and any high points.
- 4) Vent air separator by loosening screw (fig. 34) (E) and purging until no air is apparent **N.B. : ensure screw E is tightened.**

- 5) Set system charge Pressure to design cold pressure. For a new installation we suggest 1.0 bar. For an old system see section (3, 9, 2) set to system static head or 0.8 bar which ever is the greater.
 - 6) Check for water soundness and rectify any leaks.
 - 7) Switch on electrical supply.
 - 8) Manually check pump is free to rotate. Remove ca (fig. 35 D).
 - Insert small electrical screwdriver (3 mm blade), locate in slot in pump shaft, rotate clockwise to ensure that pump is free replace cap (D).
 - 9) Switch to **HOT WATER + CENTRAL HEATING** on selector switch (A) (fig. 35) switch position (II).
 - 10) Allow pump to run for further 10-15 minutes. Switch OFF.
 - 11) Isolate water supply and drain boiler by disconnecting fill system and opening the drain valve (F). This is incorporated in the safety valve and is achieved by screwing down the head until the valve lifts. Open all low level drain cocks.
 - 12) Remove filter in the return isolating valve (C) and inspect for any installation debris, see section (7.6) to clean and replace.
 - 13) Refill system as above.
- N.B.** It is recommended that this is repeated after the system has been operated up to temperature to 'hot flush' to remove fluxes and remaining debris.

6.3

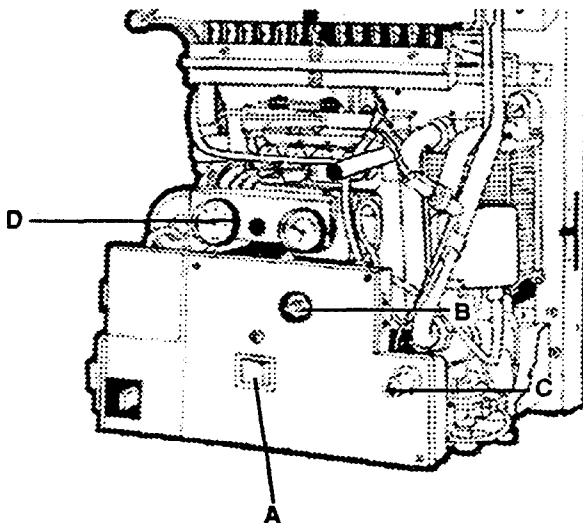

Fig. 35

Lighting the boiler

- 1) Purge gas supply. Switch on electrical supply
- 2) Turn the lever on the gas service tap (fig. 34 G) to the left. In the open position.
- 3) With yhe left hand, push in the pilot button (fig. 35 D) with the right hand push the ignitor button (fig. 35 C) When the pilot light is established, hold the pilot button pushed in for 30 seconds.
- 3) Temporarily locate the temperature control 'knob - and turn to maximum setting (fig. 35 B).
- 4) Switch to **HOT WATER + CENTRAL HEATING** (II) on the selector switch (fig. 35 A). Ensure that any auxillary controls are in the demand position the boiler will now fire automatically.
- 5) Check for gas soundness using leak detection fluid or gas detector.
- 6) Check and adjust gas pressure/gas rate, see Section 6.4.

6.4

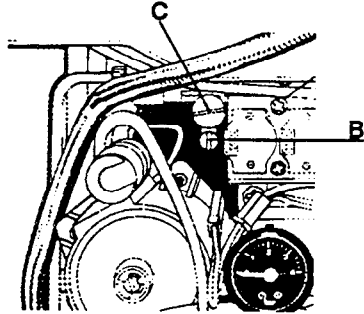

Fig. 36

Gas rate adjustment

N.B. Before adjustment check gas pressure on the inlet to the appliance, with the appliance working - this should be 20 m bar (8 in wg) for natural gas.

The maximum gas rate on hot water is fixed and is a function of the restrictor size. The central heating variable adjuster is factory set at 75 % i.e for an output of approx 16.5 kW (56248 Btu/h).

- 1) Switch boiler to the off (O) central position, see section 6.3 (fig. 35).
- 2) Remove the pressure test point screw - (B) and connect a suitable pressure gauge.
- 3) Remove the hexagonal cap from gas rate adjuster exposing the adjusting screw (C).
- 4) Switch the boiler to hot water and central heating (II) and check that any fitted external controls are calling for heat.
- 5) Adjust. Setting pressures are given in graph figs. 37 and 38. The pressure will be reduced by clockwise movement of screw, increased by anticlockwise movement. Now select hot water only, adjust temperature knob, see fig. 4 (25), to minimum and open the largest volume draw-off tap. The gas pressure should now be the maximum as indicated in Technical Data.
- 6) Switch boiler off (O). Remove pressure gauge and replace test point screw and gas rate adjuster hexagon cap. Check for gas soundness around screw.
- 7) Mark the data badge, located on the front of the combustion chamber below the sight glass to indicate output to heating system.

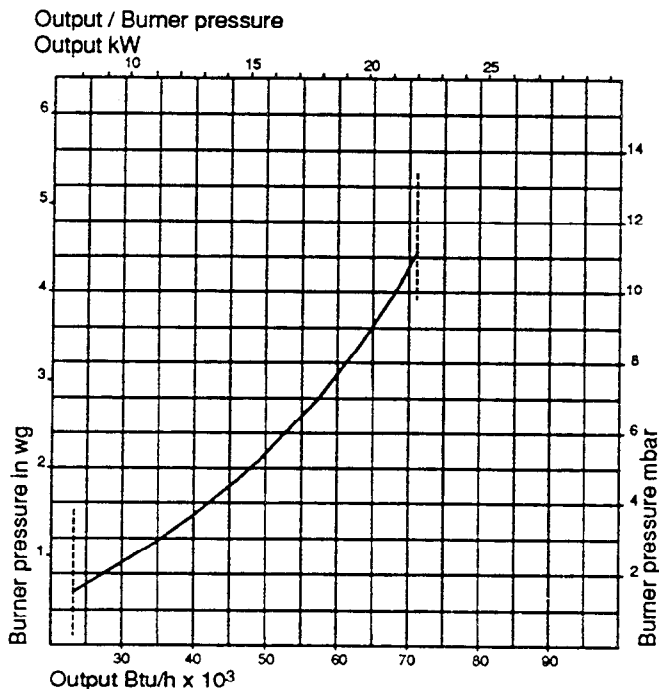

Fig. 37

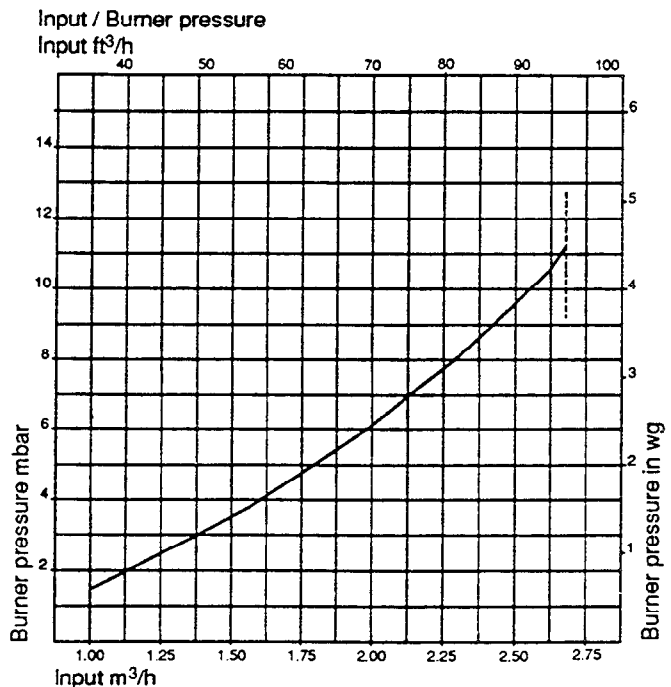

Fig. 38

6.5

D.H.W water flow rate adjustment

This is set by the installer during commissioning. See section 6.1 and 6.7.

6.6

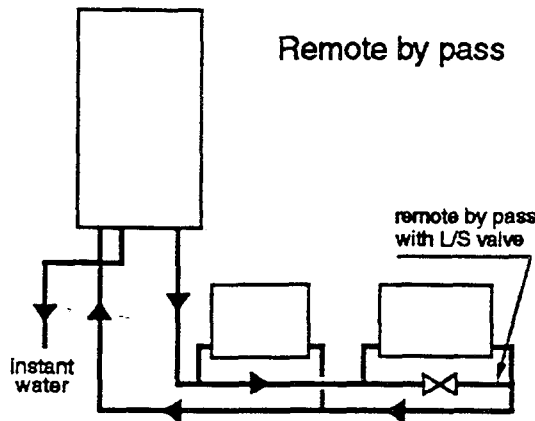

Fig. 39

Adjusting the heating system by-pass

Where a by-pass is fitted, see section 3.2, it is necessary to adjust to obtain the boiler minimum flow requirement of 300 l/h (1.1 gal/min).

- 1) Set boiler thermostat to maximum, switch boiler to HOT WATER + CENTRAL HEATING (II).
- 2) Open all radiators and close the by-pass. Check the temperature rise across the boiler which should not be greater than 20° C (36 °F).
- 3) Adjust system to minimum load. This is normally done by closing valves on all but two radiators.
- 4) Open by-pass gradually until the boiler operates quietly and the temperature rise is maintained.

N.B. The by-pass valve should be of the lock shield pattern. The flow switch operates at approx 300 l/h (1.1 gal/min).

6.7

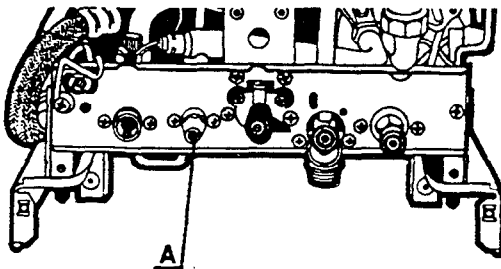

Hot water adjustment

A flow restrictor (A) is fitted on the domestic hot water outlet. Adjustment of this restrictor enables regulation of the flow rate of the D.H.W. to suit individual installation conditions and requirements.

Adjustment is made by either turning the screw in a clockwise direction to reduce the flow rate and increase the temperature or by turning the screw anti-clockwise to increase the flow rate and decrease the temperature.

6.8

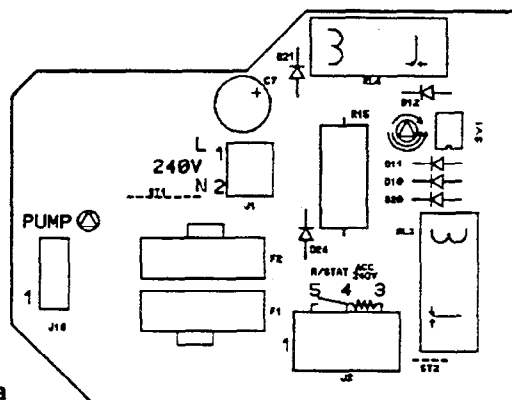

Fig. 39a

Pump adjustment

The pump is set to turn ON/OFF via the room thermostat along with the burner, when the central heating mode is selected.

It is possible if required, to have the pump running continuously by turning the switch ζ anti-clockwise, see fig. 39a.

6.9

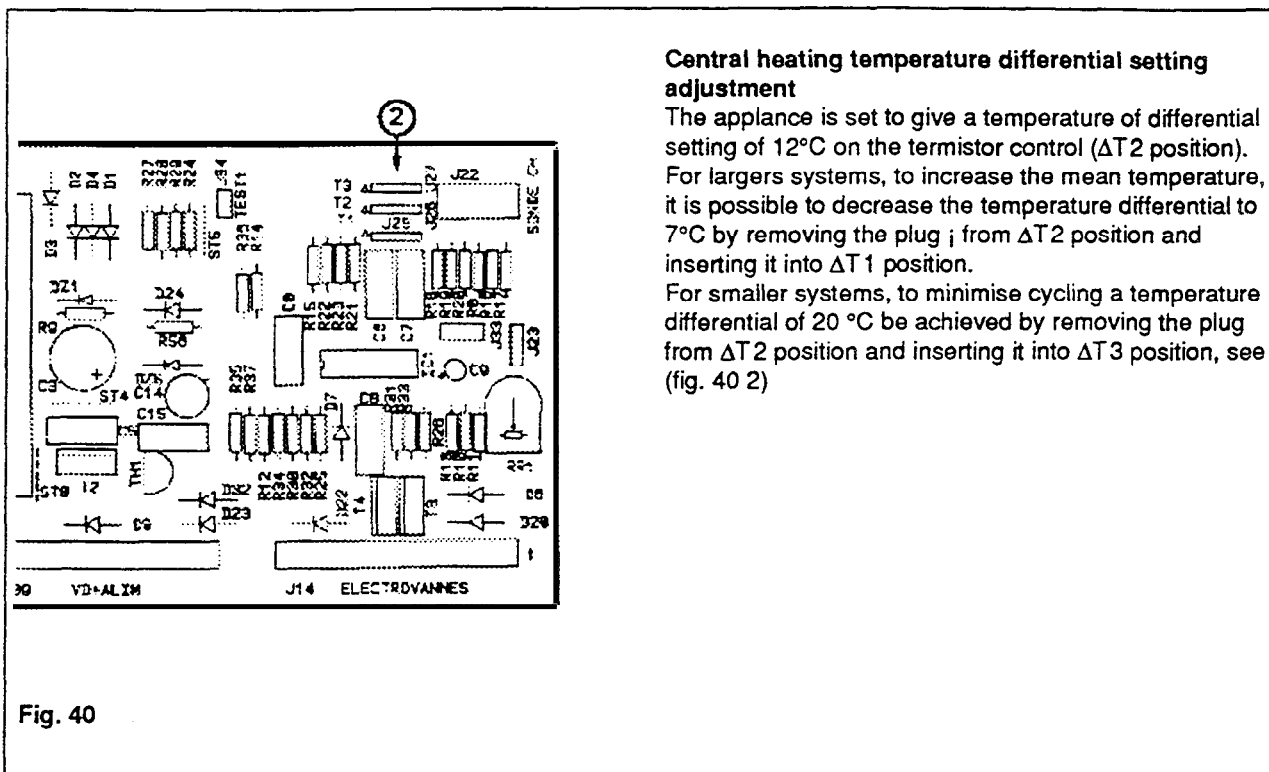

Central heating temperature differential setting adjustment

The appliance is set to give a temperature of differential setting of 12°C on the termistor control ($\Delta T 2$ position). For largers systems, to increase the mean temperature, it is possible to decrease the temperature differential to 7°C by removing the plug $\dot{\iota}$ from $\Delta T 2$ position and inserting it into $\Delta T 1$ position. For smaller systems, to minimise cycling a temperature differential of 20 °C be achieved by removing the plug from $\Delta T 2$ position and inserting it into $\Delta T 3$ position, see (fig. 40 2)

Fig. 40

6.10

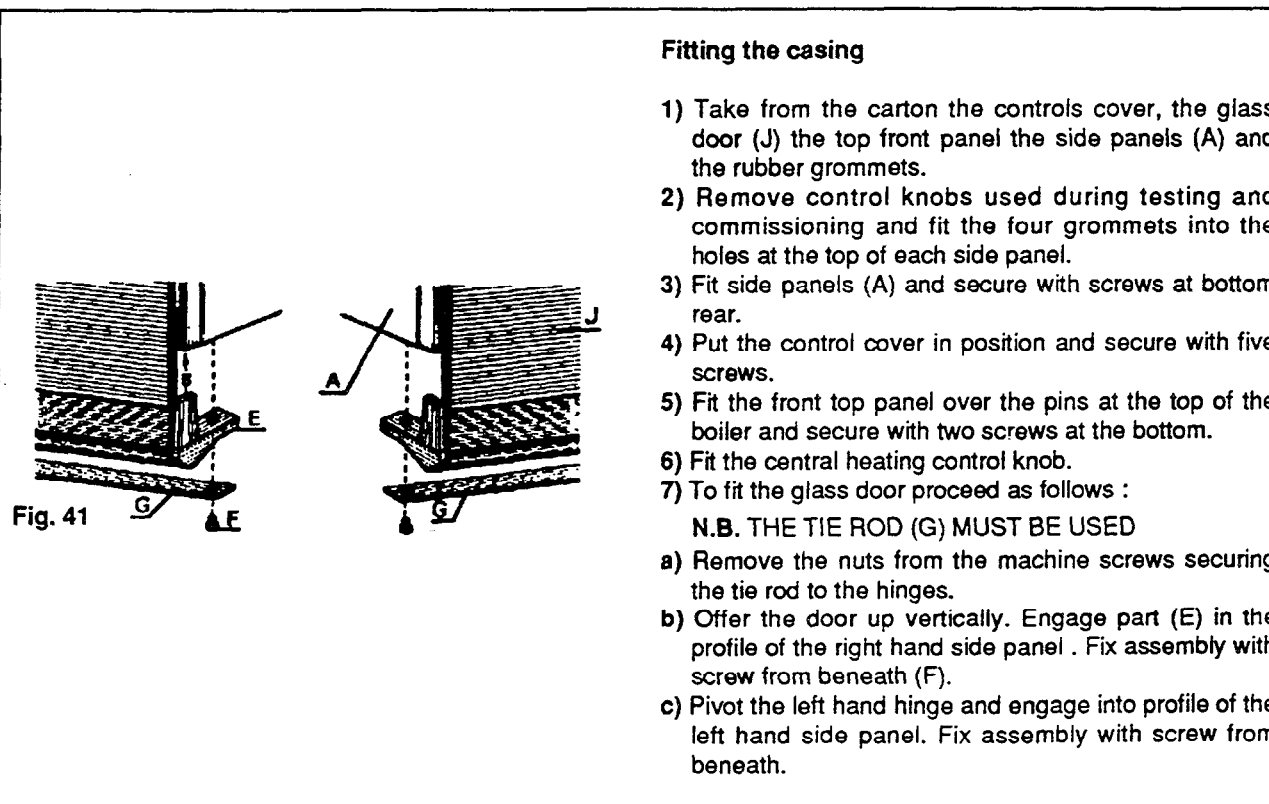

Fitting the casing

- 1) Take from the carton the controls cover, the glass door (J) the top front panel the side panels (A) and the rubber grommets.
- 2) Remove control knobs used during testing and commissioning and fit the four grommets into the holes at the top of each side panel.
- 3) Fit side panels (A) and secure with screws at bottom rear.
- 4) Put the control cover in position and secure with five screws.
- 5) Fit the front top panel over the pins at the top of the boiler and secure with two screws at the bottom.
- 6) Fit the central heating control knob.
- 7) To fit the glass door proceed as follows :
N.B. THE TIE ROD (G) MUST BE USED
 - a) Remove the nuts from the machine screws securing the tie rod to the hinges.
 - b) Offer the door up vertically. Engage part (E) in the profile of the right hand side panel . Fix assembly with screw from beneath (F).
 - c) Pivot the left hand hinge and engage into profile of the left hand side panel. Fix assembly with screw from beneath.

Fig. 41

HAND OVER THE USERS INSTRUCTIONS AND EXPLAIN THE BASIC FUNCTIONS OF OPERATING THE APPLIANCE. LEAVE THE INSTALLATION AND SERVICING INSTRUCTIONS WITH THE USER.

SHORT LIST

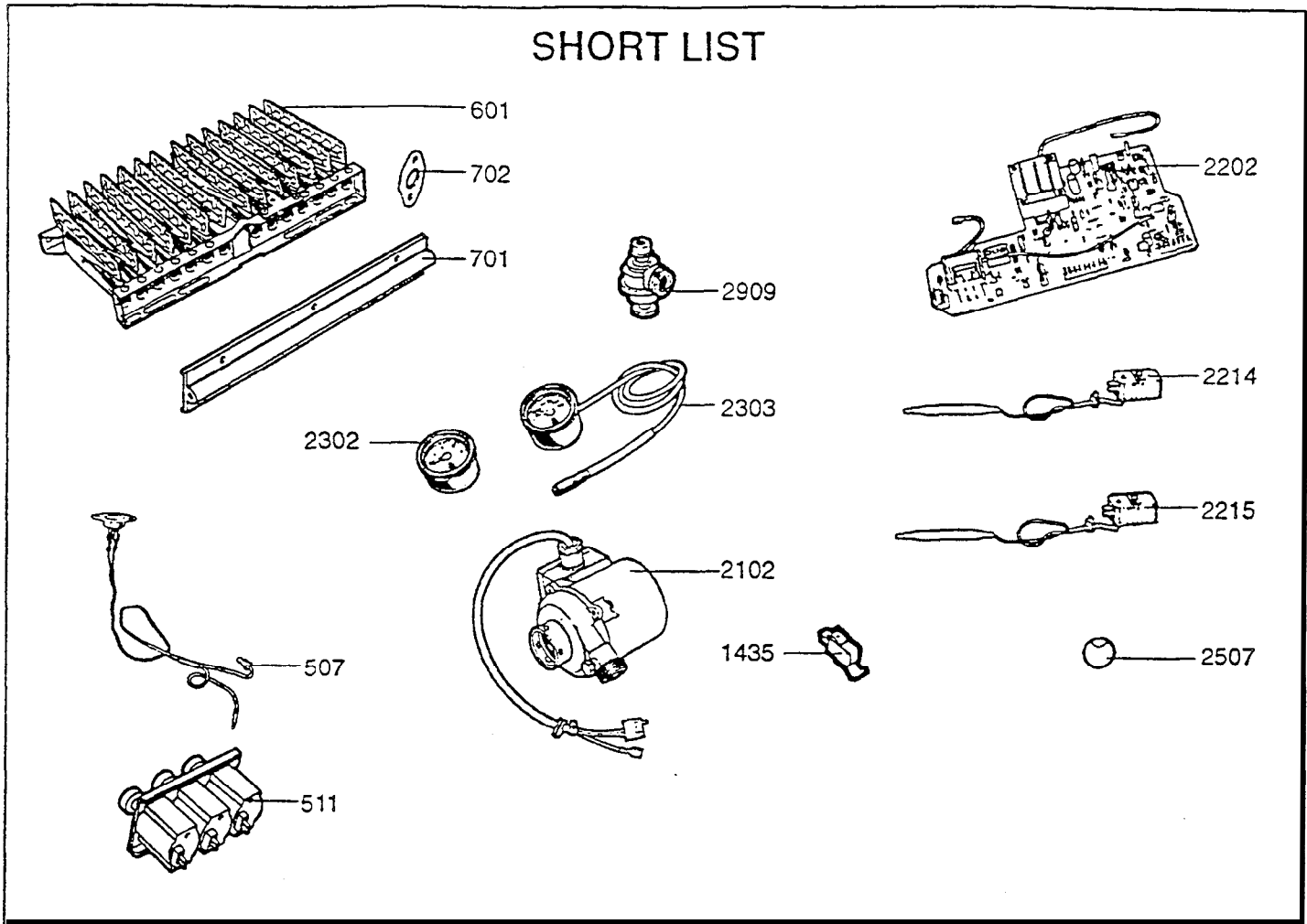

Key N°	Description	Type	G. C. NO.	MANF. PT. NO. STERLING OF
507	THERMOCOUPLE & OVERHEAT STAT			1008138.00
511	SOLENOID VALVES KIT		366865	81030.00
601	BURNER HEAD		264592	69106.00
701	MANIFOLD NAT KIT	NAT	266032	81011.00
	MANIFOLD LPG KIT	LPG	266033	81084.00
702	GASKET (Manifold).....		264477	71226.00
1435	MICRO SWITCH.(C.O.V.).....		379073	1001157.00
2102	PUMP UP 15/50.....			79505.00
2202	PRINTED CIRCUIT BOARD			1007980.00
2214	THERMOSTAT 57°C KIT.....		266060	100606.30
2215	THERMOSTAT 85°C		264649	56974.00
2302	PRESSURE GAUGE ASSY		277591	81021.00
2303	THERMOMETER ASSY		277592	81022.00
2507	BLACK POTENTIOMETER KNOB		277599	78181.00
2909	PRESSURE RELIEF VALVE.....		366051	26657.00

Imp. SH. - 92220-135 - 10.93

Chaffoteaux et Maury Limited,

Trench Lock, Trench, Telford, Shropshire TF1 4SZ
Telephone : Telford (0952) 222727 - Telefax : (0952) 243493



Looking Good. Heating Better

Notes

