

# Installation- and User Manual

- Atmos N15B - Central heating unit (suited for external cylinder)**
- Atmos N15C - Central heating unit**
- Atmos N30K - Combi-unit (central heating + hot water)**
- Atmos N30B - Central heating unit (suited for external cylinder)**
- Atmos N30C - Central heating unit**

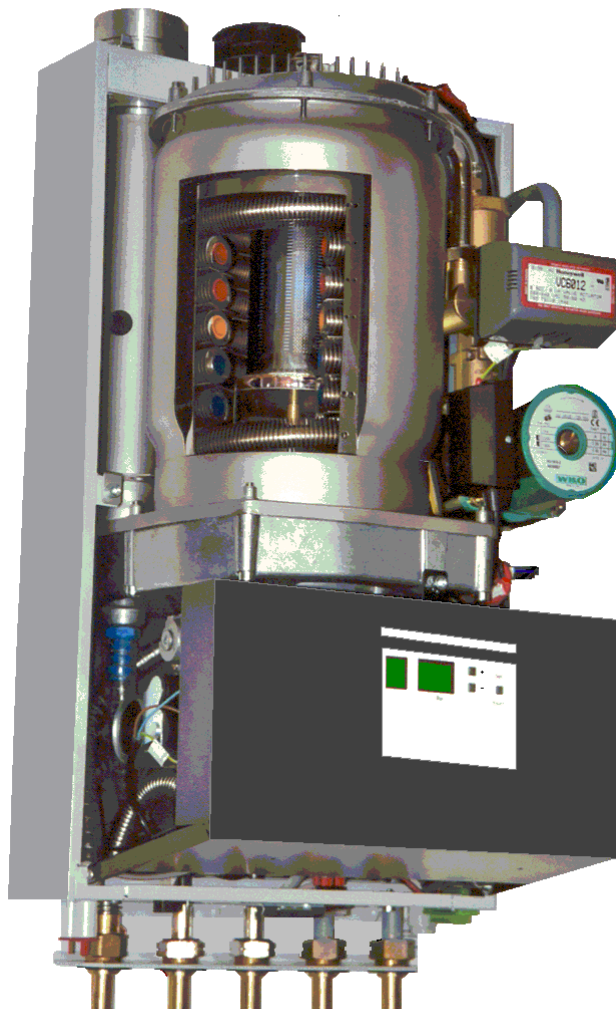

*Wall hung, fan flue, room sealed gas boilers*

**E000129012**

## CONTENTS

<b>CHAPTER 1.</b>	<b>5</b>
1.1. Technical data N15B; N15C; N30K; N30B; N30C.....	5
1.2. Dimensional sketch.....	6
1.3. Unit components.....	7
1.4. Diagrams.....	8
1.4.1 Functional flow diagram.....	8
1.4.2. Verkabelungsplan.....	9
1.5. Operation .....	10
1.6. Boiler types.....	10
1.6.1. N30K.....	10
1.6.2. N15B / N30B.....	10
1.6.3. N15C / N30C .....	10
1.6.4. Difference between type 15 and type 30.....	10
1.7. Conditions of delivery.....	11
1.8. Configuration of flue tube and air supply.....	11
1.9. Environmental conditions.....	11
1.10. Permitted flue resistance.....	11
1.11. Heating of central heating water (all models).....	11
1.12. Pump and hydraulic resistance .....	12
1.13. HWS.....	12
1.13.1. Heating of hot water (Combi-Boiler) .....	12
1.13.2. Heating of HWS (boiler with external storage cylinder) .....	12
1.14. Standards / Guidelines.....	12
1.15. General safety regulations.....	12
1.16. Water quality.....	12
<b>CHAPTER 2. INSTALLATION</b>	<b>13</b>
2.1. Mounting the rear cabinet with expansion vessel.....	13
2.2. Mounting the assembly bracket.....	13
2.3. Water and gas connections.....	14
2.3.1. Gas connection.....	14
2.3.2. Central heating water connections.....	14
2.3.3. HWS connection to the Combi-boiler.....	14
2.3.4. Hot water connection to boiler with external storage HWS cylinder.....	14
2.4. Seal on the waterside.....	14
2.5. Draconin connection.....	14
2.6. Electricity connection.....	14
<b>CHAPTER 3. SUSPENDING THE UNIT</b>	<b>15</b>
3.1. The unit .....	15
3.2. Suspension.....	15
3.3. Fitting the flue tube and air supply.....	15
3.3.1. Connecting the eccentric flue and air supply (2-pipe system).....	15
3.3.2. Connecting the concentric flue tube and air supply (80/125 mm adapter).....	15
3.3.3. Connecting the concentric flue tube and air supply (60/100 mm adapter).....	15
3.4. Condensation water drain/overpressure protection on drain.....	15
3.5. Connection block.....	15
3.5.1. On/off room thermostat (if applicable). Connect to terminals (1) and (2).....	15
3.5.2. Modulating room thermostat (if applicable) . Connect to terminals (1) and (2).....	15
3.5.3. Connection for the external temperature sensor (if applicable) Connect to terminal (3) and (4).....	16
3.5.4. Connection of the temperature sensor for the external HWS cylinder. Connect to terminal (5) and (6)	16
3.6. Assembling the connection block.....	16
3.7. Placing the jacket.....	16
<b>CHAPTER 4. COMMISSIONING</b>	<b>17</b>
4.1. Electrical power.....	17
4.2. Main switch.....	17
4.3. Filling.....	17
4.4. Reading the water pressure.....	17
4.5. Venting.....	17
4.6. Chimney sweeper function.....	17
4.7. Gas / Air Ratio.....	17
4.8. Gas / Air adjustment (CO <sub>2</sub> analysing).....	18
4.8.1. Full load.....	18

4.8.2.	Low load.....	18
4.9.	Placing the jacket.....	18
4.10.	Changing over to LPG-gas.....	18
4.10.1.	Full load on Propane.....	18
4.11.	Display.....	19
4.11.1.	Normal operation (permanent status indication).....	19
4.11.2.	blocking operation (permanent status indication).....	20
4.11.3.	Lock-out (flashing status indication).....	20
4.12.	Menu structure.....	21
<b>CHAPTER 5. TEMPERATURE REGULATIONS</b>		<b>22</b>
5.1.	Central Heating.....	22
5.1.1.	Central heating temperature regulation with on/off thermostat without outside temperature sensor.....	22
5.1.2.	Central heating temperature regulation with on/off thermostat with outside temperature sensor.....	22
5.1.3.	Central heating temperature regulation with modulating thermostat with or without outside tempensor..	22
5.2.	HWS temperature regulations.....	23
5.2.1.	Combi-boiler.....	23
5.2.1.1.	HWS heat demand.....	23
5.2.1.2.	End of hot water heat demand.....	23
5.2.1.3.	Store heat demand.....	23
5.2.1.4.	End of store demand.....	23
5.2.2.	Boiler with external HWS cylinder.....	23
5.2.2.1.	HWS cylinder with external sensor without modulating space unit.....	23
5.2.2.2.	HWS cylinder with external sensor with modulating space unit.....	23
5.2.3.	HWS cylinder with thermostat without modulating space unit.....	23
5.2.4.	HWS cylinder with thermostat with modulating space unit.....	23
<b>CHAPTER 6 BURNER STATES and MONITORING</b>		<b>24</b>
6.1.	Burner states.....	24
6.1.1.	Rest state.....	24
6.1.2.	Purging/Prestart.....	24
6.1.3.	Ignition.....	24
6.1.4.	Operation.....	24
6.1.5.	Post-ventilation.....	24
6.1.6.	Functional locking.....	24
6.2.	Monitoring.....	24
6.2.1.	Monitoring the pump circulation.....	24
6.2.2.	Pump programm.....	24
6.2.3.	Pump test programm.....	24
6.2.4.	Static pressure monitoring.....	25
6.2.5.	Difference in temperature.....	25
6.2.6.	Maximum temperature limitation.....	25
6.2.7.	Flue gas temperature limitation.....	25
6.2.8.	Flow sensor protection.....	25
6.2.9.	Frost protection.....	25
6.2.10.	Monitoring the fan speed.....	25
6.2.11.	Glow plug protection.....	25
<b>CHAPTER 7. MAINTENANCE</b>		<b>26</b>
7.1.	Annual maintenance.....	26
7.1.1.	Checking the CO <sub>2</sub> percentage on full load.....	26
7.1.2.	Measuring the load on the unit .....	26
7.1.3.	Checking the condensation water drain.....	26
7.1.4.	Ionisation probe.....	26
7.1.5.	Water pressure.....	26
<b>CHAPTER 8. MALFUNCTIONS</b>		<b>27</b>
8.1.	Draining the unit.....	27
8.2.	No signal on the display.....	27
8.3.	Fault code U/d or U/O (alternating U with a status code will appear on the display).....	27
8.4.	Unit does not respond to central heating heat demand.....	27
8.5.	Unit does not respond to HWS demand.....	27
8.6.	Three-way-diverter valve.....	27
8.7.	Check function of gas control.....	27
8.8.	Measuring the fan impedance.....	27
8.9.	Fitting instructions for the pressure sensor.....	27

8.10.	Fitting instructions for the safety valve.....	28
8.11.	Malfunction code „F“ (flashing).....	28
8.11.1.	Gas control will not open (no voltage).....	28
8.11.2.	Gas control will not open (gas inlet pressure too high).....	28
8.11.3.	Gas control will not open (coils defective).....	28
8.11.4.	Gas/Air mixture is not correctly adjusted.....	28
8.11.5.	Check glow plug.....	28
8.11.6.	Check ionisation current.....	28
8.11.7.	inspection / cleaning / replacement of the ionisation probe.....	29

**User manual**

		<b>30</b>
	General.....	30
	Cleaning the unit.....	30
	Holidays.....	30
	Brrrr, the central heating is not working.....	30
	Electricity and gas.....	30
	Water and air.....	30
	Other causes.....	30
	Display.....	31
	Reset button.....	31
	Abbreviated display indications.....	31

## CHAPTER 1.

## 1.1. Technical data N15B; N15C; N30K; N30B; N30C

Boiler type		N15B; N15C			N30K; N30B; N30C		
Gas type		natural gas G20	natural gas G25	LPG gas G30/G31	natural gas G20	natural gas G25	LPG gas G30/G31
Electrical data	Mains voltage / Frequency	230 V / 50 Hz					
	Power consumption (max.)	136 W					
	Thermostat voltage	24 V					
Dimensions and weight	High	600 mm					
	Width	360 mm					
	Depth	300 mm					
	Weight	35 kg					
Gas technical data	Nominal gas pressure	20 mbar	25 mbar	37/50 mbar	20 mbar	25 mbar	37/50 mbar
	Heat input CH (gross)	4,3 – 15,8 kW (boost for HWS =19,1 kW)			8,0 – 27,2 kW (boost for HWS =31,1 kW)		
	Heat input CH (net)	3,9 – 14,2 kW (boost for HWS =17,2 kW)			7,2 – 24,5 kW (boost for HWS =28,0 kW)		
	Nominal output CH at 80/60°C	3,8 – 14,0 kW (boost for HWS =17,0 kW)			7,1 – 24,2 kW (boost for HWS =27,6 kW)		
	Nominal output CH at 50/30°C	4,2 – 15,3 kW (boost for HWS =18,5 kW)			7,9 – 25,9 kW (boost for HWS =32,0 kW)		
	Efficiency at 80/60°C (net)	99%					
	Efficiency at 50/30°C (net)	108%					
Emission value	CO <sub>2</sub>	8.2-8.8%		9.2-9.8%	8.2-8.8%		9.2-9.8%
	CO (0% O <sub>2</sub> )	10 – 30 ppm			10 – 66 ppm		
	NO <sub>x</sub> (0% O <sub>2</sub> )	6 – 15 ppm			8 – 25 ppm		
Flue gas-temperature	at 80/60°C	< 70°C					
	at 50/30°C	< 35°C					
Maximum chimney resistance	Air feed and flue tube together	185 Pa					
Connections	Gas	Ø 15 mm					
	CH (flow and return)	Ø 15 mm; with group of taps Ø 20 mm					
	Cold water return to external cylinder	Ø 15 mm					
	Hot water flow from external cylinder	Ø 15 mm					
	Overflow	Ø 15 mm					
Air feed and flue tube system	Eccentric	Ø 60 – 60 mm					
	Concentric	Ø 80 / 125 mm					
Boiler heat exchanger	Water contents	0.8 L					
	Max. temperature	90°C					
	Max. Water pressure	3 bar					
HWS heat exchanger (internal cylinder)	Water contents				0,3l (supply 3 l)		
	Max. custom water temperature				65°C		
	Max. custom water pressure				8 bar		
Sound level	Pump high	40 dB(A)					
	Pump low	30 dB(A)					
Certification	CE Identification number	CE0063-AT3070					

**1.2. Dimensional sketch**

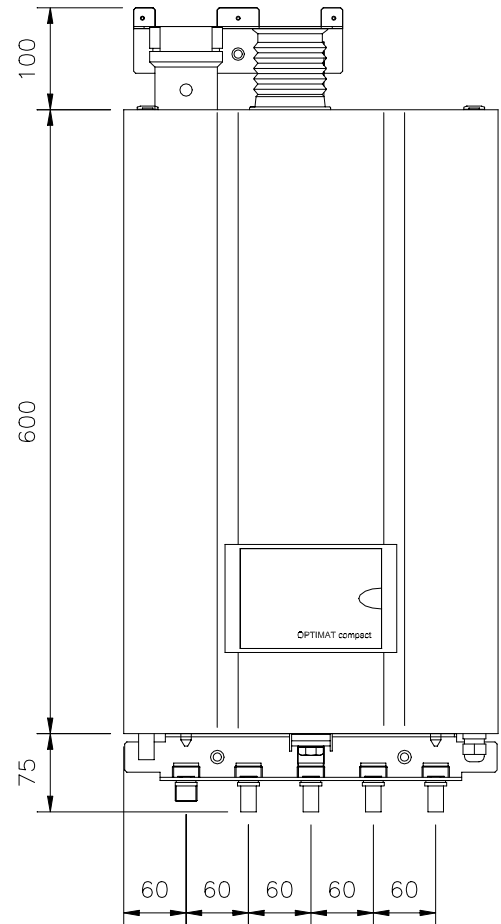
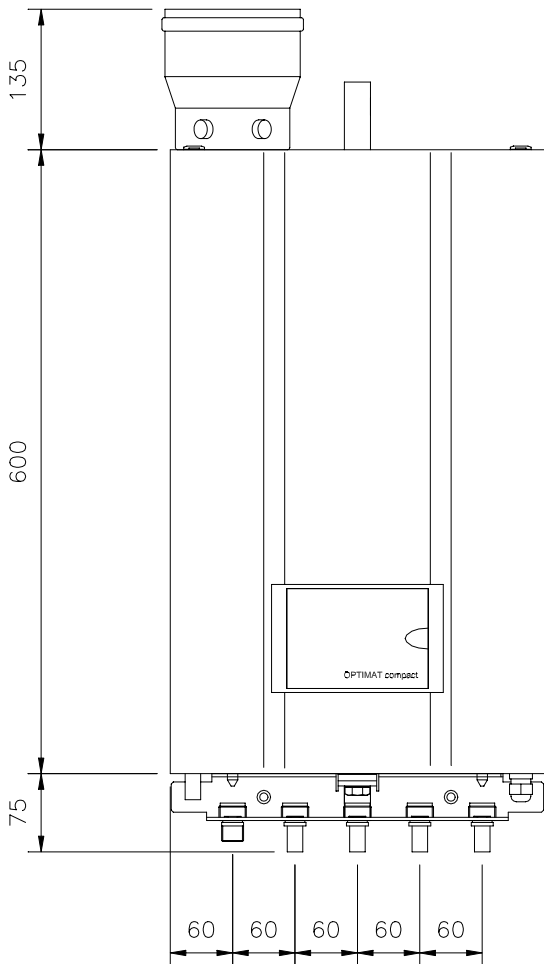
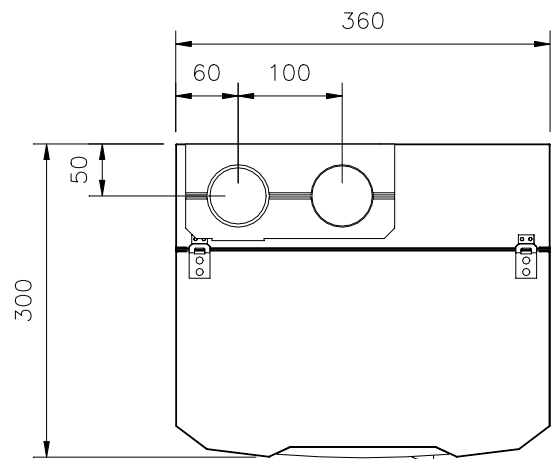
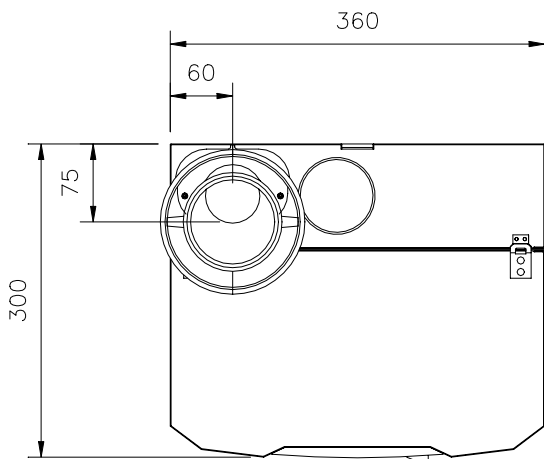

**Free space**

There must be sufficient space at the top and bottom to be able to suspend the unit and to be able to connect all feed and drain pipes. Normally, roughly 300 mm is required.

It is recommended to leave a free space of 150 mm on the left (for servicing reasons) and 50 mm on the right of the unit.

The front of the unit must be easily accessible for servicing at all times.

1.3. Unit components

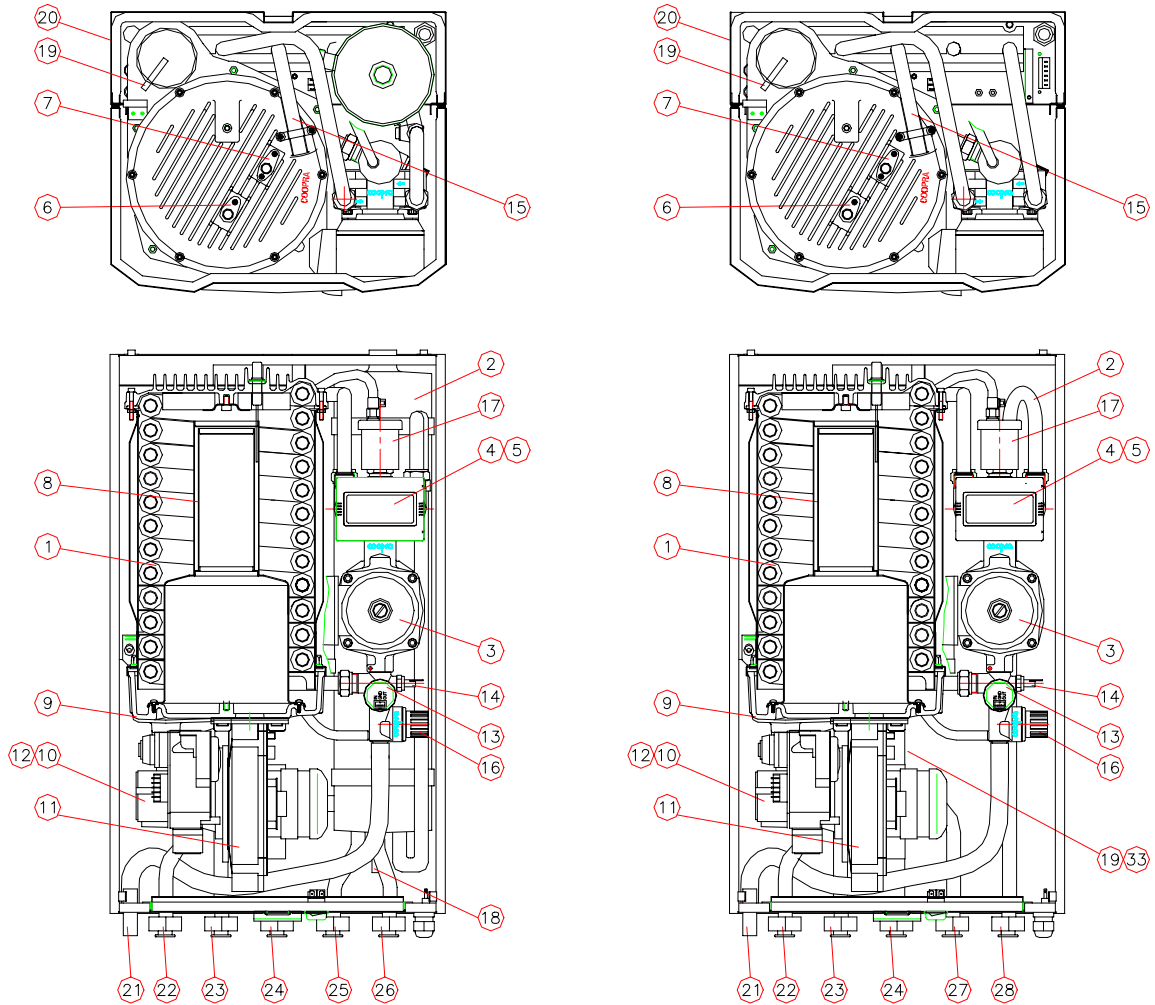

No	Description	Manufacturer	Coopra article code
1	Primary heat exchanger	Coopra	N00S040000
2	HWS cylinder	Coopra	N00S100000
3	Pump motor	Wilo	N00S110004
4	Actuator 3-way valve	Honeywell	N00S110003
5	Interior of 3-way valve	Honeywell	N00S110002
6	Glow plug	Saint Gobain	N00S070013
7	Ionisation probe	Sapco	N00S070020
8	Burner type 15	Furigas	N00S020003
8	Burner type 30	Furigas	N00S020000
9	Vapour tray	Coopra	N00S020015
10	Gas valve	Honeywell	N00S020009
11	Fan	Vibo	N00S020006
12	Venturi type 15	Honeywell	N00S020016
12	Venturi type 30	Honeywell	N00S020010
13	Water pressure sensor	Huba	N00S080028
14	Return sensor	Tasseron	N00S080011
15	Flow sensor	Honeywell	N00S070007
16	Safety device	v.d. Wetering	N00S080001
17	Float vent	Honeywell	N00S110001
18	Flue gas temperature sensor	Coopra	N00S070017
19	Temperature sensor for HWS cylinder	Coopra	N00S070017
20	Type plate	Coopra	n.a.
21	Condensation water overflow	Coopra	n.a.
22	Gas connection	Coopra	n.a.
23	Central heating return	Coopra	n.a.
24	Central heating flow	Coopra	n.a.
25	Hot water tap	Coopra	n.a.
26	Cold water tap	Coopra	n.a.
27	Feed connection to external cylinder	Coopra	n.a.
28	Return connection from external cylinder	Coopra	n.a.

1.4. Diagrams

1.4.1. Functional flow diagram

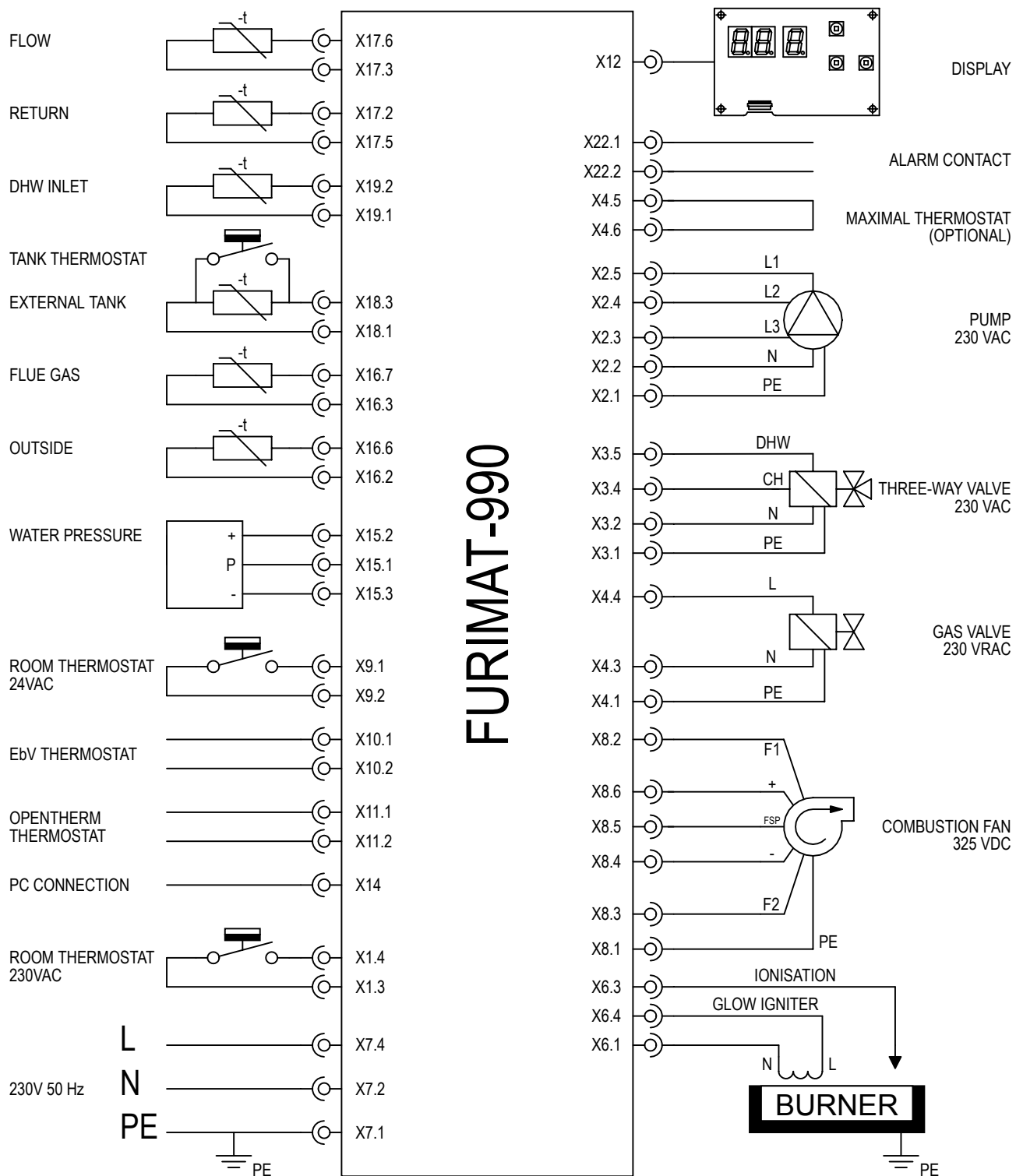



1.4.2. Wiring diagram

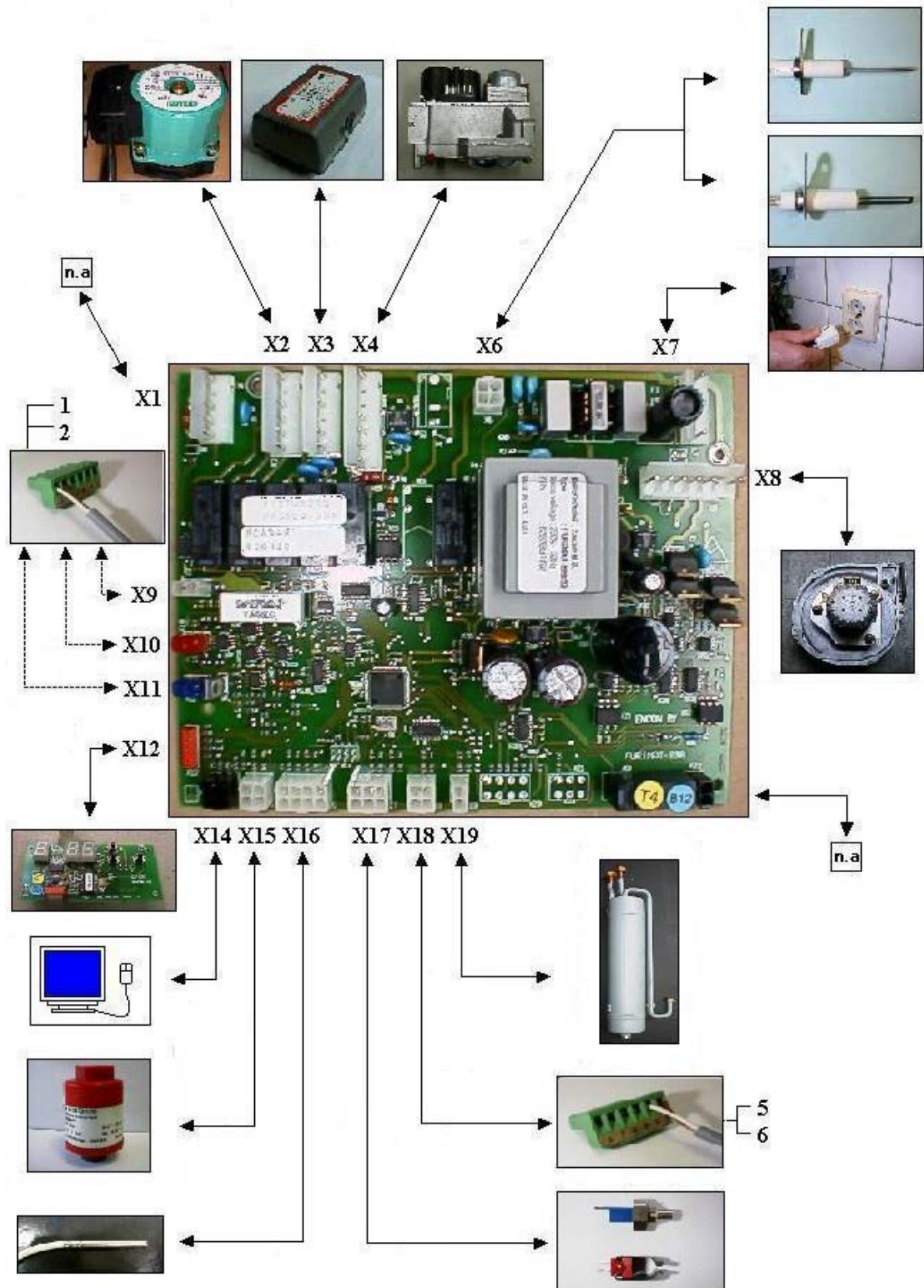

**1.5. Operation**

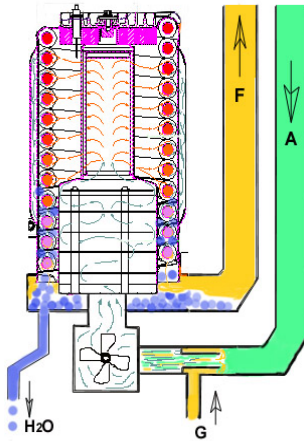

A fan sucks the air required for the combustion through the air feed canal (A). Because the combustion air in the venturi sucks an under pressure, the correct amount of gas (G) is automatically added to the combustion air. The flammable gas/air mixture thus obtained is fed to the burner, via a mixing chamber, to be ignited at the surface of the burner by a ceramic glow plug. The hot combustion gases are efficiently fed through the heat exchanger, where they give their heat to the water. The flue gases are fed outside, through the flue tube (F), into a flue tube exhaust canal. The condensation water (H<sub>2</sub>O) thus obtained is discharged into the sewer.

**1.6. Boiler types**

The Atmos boiler is a heating unit with compact dimensions and a very high efficiency, with versions for domestic use for central heating or in combination with domestic hot water (HWS). The type plate, which specifies the type of gas etc. to be used, for which the unit is set, is on the left side of the unit. The unit is fixed to the wall with the aid of a separately delivered assembly bracket or rear cabinet.

**1.6.1. N30K**

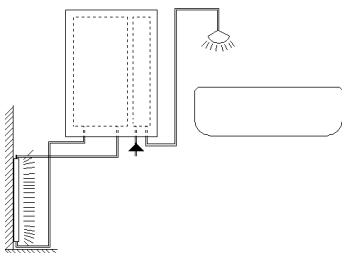

High efficiency Combi-boiler for central heating with a built-in tank (3 litres) for the supply of tap water for shower and bath, etc.

**1.6.2. N15B / N30B**

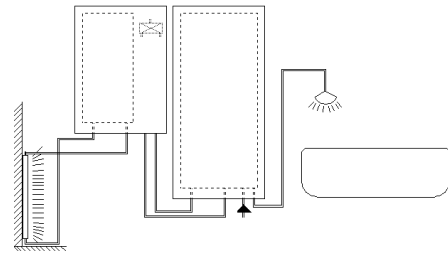

High efficiency boiler for central heating, suited for the connection of an external storage vessel for the indirect supply of tap water for shower and bath, etc.

**1.6.3. N15C / N30C**

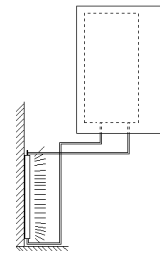

High efficiency boiler for central heating only.

**1.6.4. Difference between type15 and type 30**

Type 15	Type 30
<p><b>N00S020003</b> Burner assy</p>	<p><b>N00S020000</b> Burner assy</p>
<p><b>N00S020016</b> Venturi</p>	<p><b>N00S020010</b> Venturi</p>

### 1.7. Conditions of delivery

Atmos Heating Systems Ltd. supplies its products according to the general conditions of delivery for the metal and electro technical industry. **Registered with the Clerk of the District Court at Den Haag on 19 October 1998 under no. 119/1998.**

### 1.8. Configuration of flue tube and air supply

See figure below for an overview of possible configurations.

The units are approved for application on the drain systems:

B23, C13(x), C33(x), C43(x), C53, C63(x), C83(x).

Preferably use flue tube materials, roof ducts and exterior wall ducts with a quality mark.

With plastic drain materials, use a unit with a flue gas temperature sensor.

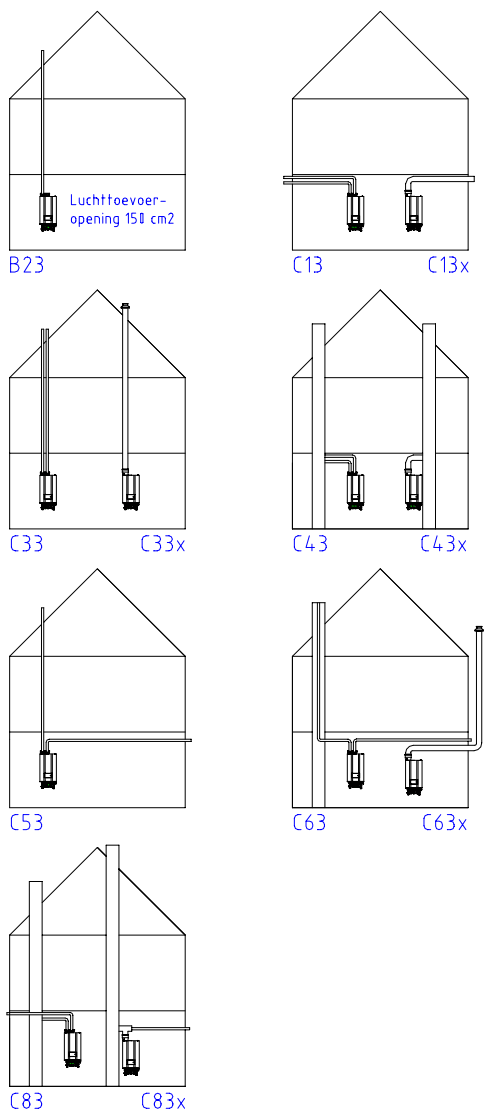

### 1.9. Environmental conditions

The area in which the unit is installed must satisfy the applicable regulations.

The wall must be able to bear the weight of the unit (loaded weight approx. 40 kg).

If you use a different assembly surface than a bricky wall of sufficient thickness, you must select suitable fixtures yourself and properly install the unit.

The unit may not be fitted in a chemically aggressive environment.

The unit with air feed and flue gas exhaust satisfies the requirements of protection class IP44 and may therefore be installed in a wet area.

Although the unit is fitted with an internal frost protection, it may not be exposed to extremely low ambient temperatures (lower than -10°C).

### 1.10. Permitted flue resistance

*The total resistance of the flue tube and air supply together may not be greater than 185 Pa.*

Indication for the resistance values given in table below apply to a flow rate of 40 m<sup>3</sup>/hour.

	Ø 80 mm	Ø 60 mm
Tube per metre	1.3 Pa	5.1 Pa
Bend 90°, R = 1.5 D	2.5 Pa	6.5 Pa
Bend 90°, R = 0.5 D	6.0 Pa	15.0 Pa
Bend 45°, R = 1.5 D	1.5 Pa	4.0 Pa
Bend 45°, R = 0.5 D	2.0 Pa	5.5 Pa
Roof duct (concentric, 1.25 m)	20.0 Pa	30.0 Pa

### 1.11. Heating of central heating water (all models)

If the room thermostat or space unit indicates that heat is required for the central heating, the unit will heat the central heating water as necessary. The power supplied is automatically adapted to the heat required and is also continuously variably adapted to the heat demand with the use of an on/off thermostat.

When the thermostat indicates that the desired temperature has been reached, the central heating water is no longer heated. The central heating pump will continue to run for a previously set time to distribute the heat evenly over the heating installation.

*A differential bypass valve must be installed on plants where it may happen that various radiators are simultaneously excluded from the circuit because of closure of control or zone valves.*

The by-pass valve must be mounted in the installation between the flow and the return, provided that flow direction indicated by arrow is respected.

To adjust the by-pass valve rotate knob of the graduated scale on setting 2.5-3.0. This value corresponds to the meters of pump head (m H<sub>2</sub>O).

Lock the screw on the groove knob.

### 1.12. Pump and hydraulic resistance

The pump characteristic and the resistance graph of the unit are given below.

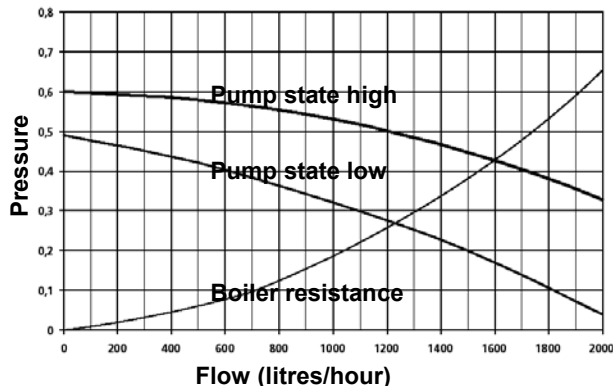

If set on automatic function the electronics switches the speed of the pump to "high" or "low", depending on the temperature demand:

- $Dt > 30\text{ }^{\circ}\text{C}$  : the pump runs „high speed“ (2200 rpm)
- $Dt < 10\text{ }^{\circ}\text{C}$  : the pump runs „low speed“ (1750 rpm)

$Dt$  = Setpoint temperature deducted with the actual Flow temperature.

### 1.13. HWS

#### 1.13.1. Heating of hot water (Combi-boiler)

When one of the hot water taps is opened, the unit will automatically start to heat the hot water.

With a view of the comfort of the user, the central heating operation will be interrupted (if applicable).

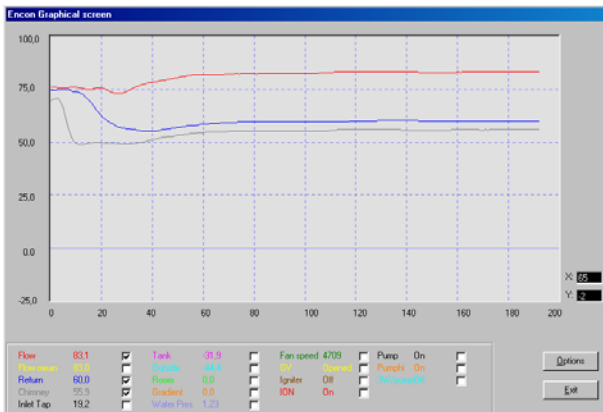

The final hot water temperature that is reached depends on the temperature of the cold inlet water, the amount of HWS water that is used and the HWS set temperature.

For the standard HWS temperature setting of  $60\text{ }^{\circ}\text{C}$ , the following applies with  $10\text{ }^{\circ}\text{C}$  cold water supply

- With  $3.5\text{ l/min}$  (kitchen function), the final temperature is  $64\text{ }^{\circ}\text{C}$ .
- With  $7.5\text{ l/min}$  (shower function), the final temperature is  $60\text{ }^{\circ}\text{C}$ .
- With  $12.5\text{ l/min}$  (bath function), the final temperature is  $45\text{ }^{\circ}\text{C}$ .

On initial HWS demand water can flow out of the tap at a temperature of  $70\text{ }^{\circ}\text{C}$  for several seconds.

#### 1.13.2. Heating of HWS (boiler with external storage cylinder)

When one of the hot water taps is opened, the HWS stored in the storage HWS cylinder will immediately start to flow. While water is being taken from the storage HWS cylinder, the unit will start to heat the storage HWS cylinder. During this period, the central heating operation will be interrupted (if applicable).

#### 1.14. Standards / Guidelines

With the installation of the unit, all local regulations must be followed, where applicable, including the provisions of the following standards and guidelines:

- Building Regulations
- Regulations for natural gas installations
- Regulations for LPG (if applicable)
- Guidelines for existing gas installations
- Safety requirements for central heating installations
- Safety provisions for low voltage installations
- General regulations for drinking water installations
- Water authority regulations
- Ventilation in dwellings
- Supply of combustion air and exhaust
- House sewerage in homes and dwellings
- Fire Brigade regulations
- Factory Act regulations
- Regulations applicable to HWS water Ask for the locally applicable regulations at the local water company as they are different in some areas

#### 1.15. General safety regulations

The installation may only be performed by a recognised installer.

Take note that internal parts of the unit can carry a dangerous electrical voltage ( $230\text{ Volt}$ ).

Take note that the unit, the various pipes and the flue gas exhausted by the unit can reach high temperatures (up to  $90\text{ }^{\circ}\text{C}$ ).

Before carrying out maintenance activities in or on the unit, you must close the gas tap, switch off the electricity supply and pull the mains plug out of the socket.

#### 1.16. Water quality

The composition and quality of the system water has a direct effect on the performance of the total system and the life of the boiler heat exchanger. Great care must be used with the addition and use of chemicals, water softeners, oxygen binders, de-aerators, aerators and water filters as they increase the chance of malfunctions.

Corrosive elements of certain additives can attack the system and cause leakages; the build-up of undesired deposits generally leads to fatal damage of the heat exchanger.

## CHAPTER 2. INSTALLATION

### 2.1. Mounting the rear cabinet with expansion vessel

Mount the frame level to the wall.



Remove the red cap from the pipe and place this end of the pipe on the side connection of the T-piece 15x15x1/2"



Place the pipe with T-piece in the frame.



Place the manual vent in the T-piece at the top of the frame.



Fit the pipe in the second hole from the left and connect the T-piece 15x15x15 to the previously placed pipe.



Place the expansion vessel and connect it to the flat flange (above). Place the rest of the pipes.

### 2.2. Mounting the assembly bracket

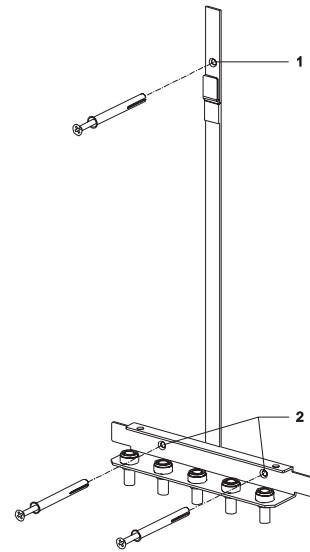

To mount the assembly bracket on a brick wall of sufficient thickness, use the screw plugs that are supplied. When you have determined the place of assembly, proceed as follows:

1. Draw the position of the hole (1) in the strap of the assembly bracket.
2. Use a masonry drill of 8 mm diameter to drill a hole with a sufficient depth in the wall.
3. Keep the hole (1) in the assembly bracket in front of the hole in the wall and fit one of the screws supplied through the assembly bracket in the hole.
4. Align the assembly bracket with the aid of a spirit level.
5. Use a masonry drill of 8 mm diameter to drill holes with a sufficient depth in the wall through the two bottom holes (2) in the assembly bracket.
6. Fit two of the screws supplied in the bottom holes.
7. When using assembly brackets with a clamping plate for eccentric flue tube and air feed connection:
  - Use a masonry drill of 8 mm diameter to drill a hole with a sufficient depth in the wall through the hole in the clamping plate and fit a nail plug in this hole.
  - Fit the clamping plate at right angles.
8. Fix the assembly bracket firmly by tightening all screws.

## 2.3. Water and gas connections

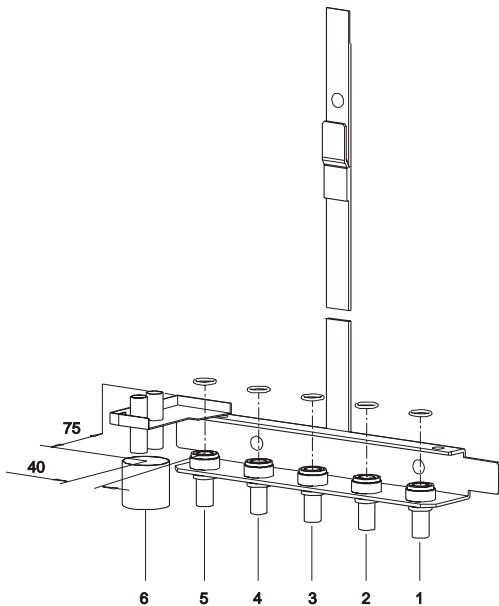

- 1 = cold water pipe  
 2 = hot water pipe  
 3 = central heating flow pipe  
 4 = central heating return pipe  
 5 = gas connection

### 2.3.1. Gas connection

- Connect the gas pipe to connection (5).
- Install the gas pipe stress free.
- Include an approved stopcock in the pipe.
- Carefully blow the gas pipe clean.

### 2.3.2. Central heating water connections

- Connect the central heating flow pipe to connection (3).
- Connect the central heating return pipe to connection (4).
- A differential bypass valve must be installed on plants where it may happen that various radiators are simultaneously excluded from the circuit because of closure of control or zone valves.
- Install a filling and draining device in the central heating system. Do not use the overflow valve as a drain. The overflow valve is a safety valve that ensures that the system is not subjected to a too high pressure (max 3.5 bar).
- Stopcocks must be fitted in the central heating flow pipe (3) and the central heating return pipe (4).
- The central heating return pipe (4) must be fitted with a suitable expansion vessel. The size of the expansion vessel must be determined on the basis of the central heating water temperature and the total water content the installation contains.
- If it may be expected that the central heating water will be severely contaminated by under floor heating, fitting is a 2 kg dirt filter in the return pipe is recommended. Coopra cannot give a guarantee for.

- Damage to the unit that is caused by dirt in the system.
- Before connecting the unit, rinse the system completely to remove all contamination.

### 2.3.3. HWS connection to the Combi-boiler

- Connect the cold water pipe to connection (1).
- Remember to include a suitable inlet combination and a stopcock in the pipe. This part must be water authority approved.
- Connect the hot water pipe to connection (2).

### 2.3.4. Hot water connection to boiler with external storage HWS cylinder

- Connect the return pipe of the external cylinder to connection (1).
- Remember to connect a suitable inlet combination and a stopcock in the pipe to the storage HWS cylinder. This part must be approved.
- Connect the flow of the external cylinder to connection (2).

### 2.4. Seal on the waterside

With the use of the group of taps, you can now make a check on the seal on the waterside of the system.

### 2.5. Draconin connection

There must be a connection for the removal of the condensation water to the drain. This connection must be fitted with a trap to prevent smell problems. A tundish connection must be made because of possible overpressure or underpressure in the drain. Fit the condensation drain pipe (6) (inner diameter 40 mm minimum) several centimetres left of the gas pipe.

### 2.6. Electricity connection

There must be an electrical outlet with earth connection available at a maximum distance of 1 m from the unit.

The electricity connection (230 VAC) must consist of live, neutral and earth

A good earth connection is a requirement for good operation of the unit.

**CHAPTER 3. SUSPENDING THE UNIT**

**3.1. The unit**



Before unpacking the unit, check whether the type of gas to be used corresponds with the specification on the packing. If you have any questions, contact your supplier. To prevent back injury, take account of the fact that the weight of the unit is roughly 35 kg.

**3.2. Suspension**

Place an O-ring in the middle of each of the connections present (1) to (5).

Remove the caps from the pipes of the unit.

Keep the unit straight against the wall at about 5 cm above the site of the mounted assembly bracket or the assembly cabinet.

Press the unit into the guide and let it drop carefully, so that the hook on the suspension bracket falls into the opening at the rear of the unit and the pins at the bottom of the unit fall in the corresponding openings in the suspension bracket. Here, the connection pipes of the unit fall over the connection points of the suspension bracket.

Firmly tighten the union nuts of each of the connections present (1) to (5) with the aid of a spanner.

**3.3. Fitting the flue tube and air supply**

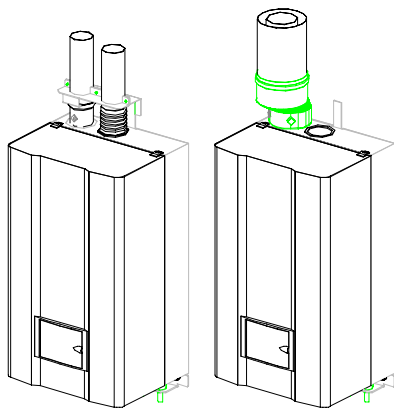

**3.3.1. Connecting the eccentric flue and air supply (2-pipe system)**

When the flue tube and air supply are connected eccentrically, proceed as follows:

1. Fit the flue tube in the opening, in the suspension bracket.
2. Let the pipe protrude 30 -35 mm under the clamping plate.
- Slide the sliding piece (1) upwards over the flue tube.
3. Fit the air supply in the opening in the suspension bracket.
4. Let the pipe protrude 40 - 45 mm under the clamping plate.
5. Fit the rubber bellows over the air supply pipe and seal them with the hose clip.
6. Fit the clamping plate on the suspension bracket and tighten it with the three screws supplied. Take care here

that the clamping plate falls in the groove of the sliding piece.

**3.3.2. Connecting the concentric flue tube and air supply (80/125 mm adapter)**

When the flue tube and air supply are connected concentrically, proceed as follows:

1. Fit the 80/125 mm adapter on the unit before you place the unit.
2. After you have placed the unit, fit the concentric pipes on the 80/125 mm adapter.

**3.3.3. Connecting the concentric flue tube and air supply (60/100 mm adapter)**

When the flue tube and air supply are connected concentrically, proceed as follows:

1. Fit the 60/100 mm adapter on the unit before you place the unit.
2. After you have placed the unit, fit the concentric pipes on the 60/100 mm adapter.

**3.4. Condensation water drain/overpressure protection on drain**

Make a tundish between the condensation water drain/overpressure protection of the unit and the drainpipe.

**3.5. Connection block**

The connections of the green connection block are all volt-free contacts. Therefore, do not connect 230 Volts to them!

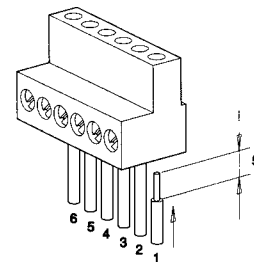

<b>terminals (1) - (2)</b>	Connection for 24 Volt thermostat
<b>terminals (3) - (4)</b>	Connection for 12 kOhm external temperature sensor
<b>terminals (5) - (6)</b>	Connection for 10 kOhm or 12 kOhm sensor of external cylinder

If no on/off room or modulating room thermostat is used at all, terminals (1) and (2) must be connected by wire.

**3.5.1. On/off room thermostat (if applicable). Connect to terminals (1) and (2)**

The on/off room thermostat (24 V) must be fitted in the same building as the unit.

Strip about 5 mm off the insulation of the wires of the room thermostat. Stick the stripped ends of the wires into connections (1) and (2) of the connection block. Make sure that the wires do not make a short circuit. Firmly tighten the screws in the connection block.

**3.5.2. Modulating room thermostat (if applicable). Connect to terminals (1) and (2)**

The modulating room thermostat must be fitted in the same building as the unit.

Strip about 5 mm off the insulation of the wires of the room thermostat. Stick the stripped ends of the wires into connections (1) and (2) of the connection block. Make sure that the wires do not make a short circuit. Firmly tighten the screws in the connection block.

When using a modulating thermostat, the plug on the printed circuit board must be connected with the correct polarity.  
 To reach the printed circuit board, the black casing must be opened. Connect the plug for the relevant modulating space unit to terminal a, b or c, according to the following photograph.

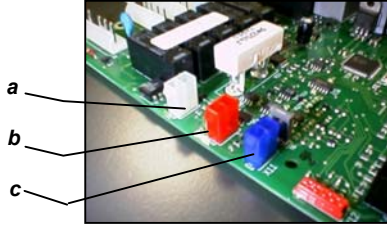

a	White	Connection for an on/off room thermostat	24 Volt
b	Red	Connection for RS30 with Atmos protocol	EBV space regulation
c	Blue	Opentherm connection	Honeywell or TEM space regulation

**3.5.3. Connection for the external temperature sensor (if applicable).**

**Connect to terminals (3) and (4)**

If an external sensor is connected, this temperature sensor must be an NTC with a resistance of 12 kOhm at 25°C.

Strip about 5 mm off the insulation of the wires of the sensor. Stick the stripped ends of the wires into connections (3) and (4) of the connection block, see figure 8. Make sure that the wires do not make a short circuit. Firmly tighten the screws in the connection block.  
 If an external sensor is not used, terminals (3) en (4) can remain open.

**3.5.4. Connection of the temperature sensor for the external HWS cylinder (if applicable).**

**Connect to terminals (5) and (6)**

If an external HWS cylinder is used, the temperature sensor must be an NTC with a resistance of 12 or 10 kOhm at 25°C. The correct version can be programmed later in the menu of the Manager.

Strip about 5 mm off the insulation of the wires of the sensor. Stick the stripped ends of the wires into connections (5) and (6) of the connection block, see figure 8. Make sure that the wires do not make a short circuit. Firmly tighten the screws in the connection block.

**3.6. Assembling the connection block**



Connect the green connection block in the green socket.

**3.7. Placing the jacket**

Place the jacket in the appropriate hooks at the top of the unit. Let the jacket pivot until it falls over the unit. Tighten the fastener at the bottom of the jacket.



## CHAPTER 4. COMMISSIONING

### 4.1. Electrical Power

Place the mains plug (if used) with earth connection in the socket or switch on the electrical supply. (230 VAC).

If the display of the unit gives the status code 'U' (alternately with an arbitrary other code), this means the live and neutral connections are reversed. Isolate the supply and reverse the connections.

### 4.2. Main switch



To power up the appliance please switch the main switch on.

### 4.3. Filling

During filling with water, the unit must be connected to the mains and be switched on. Fully open all radiator taps. Connect the water supply to the filling connection. If the unit is not yet filled with water, the display shows a flashing 'P'. The two numbers on the display give the water pressure.

Open the tap to fill the system with water. When the water pressure is sufficient (> 1.3 bar), the flashing 'P' disappears from the display. Close, after filling, the filling tap again.

### 4.4. Reading the water pressure

*It is possible to read the water pressure directly from the display. To do this, press the + button of the display for a minimum of 5 seconds.*

The unit switches out of the menu back to normal operation:

- automatically after about 5 minutes;
- or if you press the - button of the display shortly.

### 4.5. Venting

*After filling, the heating installation must be vented.*

Proceed as follows:

Follow the instructions from the manufacturer/installer for the venting of possible other elements of the heating installation, such as underfloor heating.

Fully open all radiator taps.

Open the air bleed cocks of the radiators one at a time.

Use an air bleed key for this.

As soon as water comes out of the air bleed cock, shut the cock off again.

### 4.6. Chimney sweeper function

The chimney sweeper function has priority over the central heating and HWS regulation.



The chimney sweeper function is activated by simultaneously pressing the "+ and the - buttons" of the display in for longer than 5 seconds.

The ionisation current can be read in microamperes in the two right segments.

The capacity that is immediately released is the maximum central heating capacity.



 Press the "-" button" to go to low load.



 Press the "+" button" to switch back to the preset full load capacity.

### 4.7. Gas / Air Ratio

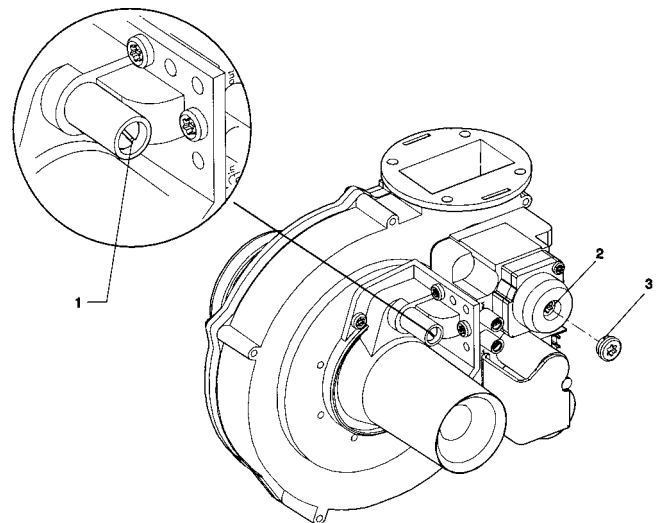

(1). **Venturi screw** – Full load adjustment

Turn the venturi screw anti-clockwise to increase the CO<sub>2</sub> value, clockwise to decrease it.

(2). **Gas control screw** – Low load adjustment

Turn the screw anti-clockwise to decrease the CO<sub>2</sub> value on low load, clockwise to increase it.

(3). **Cover screw**

**Pre-adjustment to be done in voltage-free condition:**

- **LPG GAS** – Turn venturi-screw clockwise ☹ completely down on its seat.  
Then turn the venturi screw anti-clockwise ☺ for 2 complete turns.
- **NATURAL GAS** – Turn venturi-screw clockwise ☹ completely down on its seat.  
Then turn the venturi screw anti-clockwise ☺ for 4 complete turns.

<p><b>PRE- ADJUSTMENT MEASUREMENT:</b></p> <p>Distance between Venturi-screw (1) and the Top of the venturi-stud to be about:</p> <ul style="list-style-type: none"> <li>✓ 12.5 mm for natural gas G25</li> <li>✓ 14.1 mm for natural gas G20</li> <li>✓ 16,5 mm for LPG gas G31</li> </ul>
---

With a vernier callipers the distance between venturi-screw (1) and the Top of the venturi-stud (1) has to be measured to find the rough setting of the venturi screw for full load, and depending of the used gastype. The exact adjustment of the setting has to be made using the CO<sub>2</sub> analysing method as described below.

**4.8. Gas / Air adjustment ( CO<sub>2</sub> analysing)**

The gas control is set in the factory to the type of gas to be used. This type of gas is stated on the packing and on the identification plate. To check the setting, you have to make a flue gas analysis.

**Proceed as follows**



Remove the measuring cap from the flue tube.  
Fit the measurement probe of a flue gas analyser (CO<sub>2</sub> meter) in the measurement opening of the flue tube canal.  
Make sure there is sufficient heat dissipation through the heating.

CO <sub>2</sub> setting	At full central heating load (P=100%)	At low load
Natural gas (G20, G25)	8,8-9.4 % CO <sub>2</sub>	8,2-8,6 % CO <sub>2</sub>
Propane (G31)	9,8 % CO <sub>2</sub>	9,2% CO <sub>2</sub>

**4.8.1. Full load**

The burner has to burn at maximum central heating capacity (Menu setting P=100%).

*Activate the chimney sweeper function on full load.*



Read the CO<sub>2</sub> value on the analyser. If the value does not correspond with the value in the "CO<sub>2</sub> setting" table, carefully adjust the venturi screw (1). Turn the venturi screw anti-clockwise to increase the CO<sub>2</sub> value, clockwise to decrease it.

**4.8.2. Low load**

*Activate the chimney sweeper function on low load*



Read the CO<sub>2</sub> value on the analyser. If the value does not correspond with the value in the "CO<sub>2</sub> setting" table, carefully adjust the gas control adjusting screw (2). To do this, temporarily remove the cap (3) with the aid of a Torx screwdriver.

Turn the screw anti-clockwise to decrease the CO<sub>2</sub> value on low load, clockwise to increase it.

At the end of the flue gas analysis, set the central heating capacity (P) in the menu again to the value that is best suited for the application.

**4.9. Placing the jacket**

Place the jacket in the appropriate hooks at the top of the unit. Let the jacket pivot until it falls over the unit. Tighten the fastener at the bottom of the jacket.

**4.10. Changing over to LPG-gas**

**First: the venturi adjusting screw fully clockwise until it blocks.**



Fit a flue gas analyser (CO<sub>2</sub> meter) in the measurement opening of the flue tube canal.

**4.10.1. Full load on Propane**

Set in the menu the capacity "P" to 100%.

*Activate the chimney sweeper function on full load.*

Unscrew the venturi adjusting screw four full turns anti-clockwise.  
(A guide for the dimension from the top of the screw to the top of the support is 16.1 mm).

Read the CO<sub>2</sub> value on the flue gas analyser. If the value does not correspond with the value for propane gas G31 (9,8% CO<sub>2</sub>), carefully adjust the venturi screw until the correct value is obtained.



If the gas control is already properly adjusted for natural gas, then the low load will not need to be adjusted. Activate the chimney sweeper function on low load.

Check the CO<sub>2</sub> value at minimum capacity for propane gas G31 (9.2% - 9.5% CO<sub>2</sub>). If necessary, adjust the gas regulator screw until the correct value is obtained. Note that this setting is a critical one.

**4.11. Display**

- A = display
- B = + button
- C = Set / Reset
- D = Status display
- E = - button

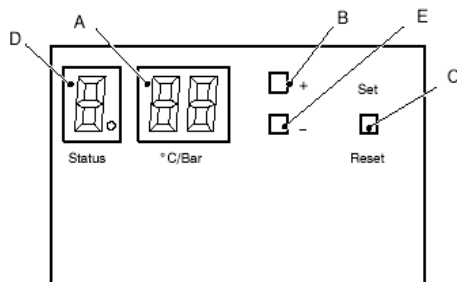

During operation, the display shows the status of the unit in the form of a code. To be able to read the codes, open the cover in front of the display. The display consists of three 7-segment LED's + three decimal points and three pushbuttons. The left 7-segment LED shows the status or the menu step. The two right 7-segment LED's show the temperature, the pressure or the parameter value.

**4.11.1. Normal operation (permanent status indication)**

The Normal operation is to indicate the burner action.

--	Initialisation after restoration of supply power
O	No heat demand, stand-by
C	Central heating heat demand, burner off
C.	Central heating heat demand, burner on
P/C.	Central heating heat demand, low load water pressure
A/C.	Central heating heat demand, low load chimney temperature
c	Central heating pump post-running
d	HWS / heating-up operation burner off
d.	HWS / heating-up operation burner on
P/d.	HWS / heating-up, low load water pressure
A/d.	HWS / heating-up, low load chimney temperature
d.	HWS / heating-up operation burner on
H	Post-running of pump HWS
b	Burner off / post-running of pump for external HWS cylinder
b.	Burner on
P/b.	Boiler, low load by water pressure
A/b.	Boiler, low load by chimney temperature
O	Frost protection burner off pump running 8C
o.	Frost protection burner on 3C
C (flashing)	Chimney function (temp display max/min/ionisation)

**4.11.2. Blocking operation (permanent status indication)**

The burner stopped burning due to an incorrect situation. The display gives a permanent indication (not flashing) and the operation can be restored by switching it off and on (volatile block).

U/ code	Reversed neutral and line	Power supply line not correctly connected
1	Flow sensor open circuit	Faulty flow sensor Wiring interrupted or not correctly connected
1.	Flow sensor short circuit	Faulty flow sensor Faulty wiring
2	Return sensor open circuit	Faulty return sensor Wiring interrupted or not correctly connected
2.	Return sensor short circuited	Faulty return sensor Faulty wiring
4	Flue gas sensor open circuit	Faulty flue gas sensor Wiring interrupted or not correctly connected
6	Cold water sensor open circuit	Faulty internal tank sensor Wiring interrupted or not correctly connected
6.	Cold water sensor short circuited	Faulty internal tank sensor Faulty wiring
A	Flue gas temperature > 80°C	The burner is reduced to low load
H	Flow sensor > 105°C while the burner was off	Reset the supply power by the on/off switch
E	Internal error	Reset the supply power by the on/off switch
P	Pump test / Start function blocking / Water pressure	Check the central heating system pressure Seized or faulty pump or faulty pump wiring Faulty pressure sensor or wiring
nc	Burner Manager fault	Reset the supply power by the on/off switch

**4.11.3. Lock-out (flashing status indication)**

In case of lock-out the display gives a flashing indication and the operation can be restored by pressing the reset button, placed on the control panel.









1	Boiler does not pass start temperature test	Check system water flow; second system pump
2	Too many restarts	
3	Internal regulation fault / A/D conversion fault / external sensor fault / Too many restarts	
5	Fan fault	
7	Gas valve fault	
8	Flame detected with closed gas valve	Check gas valve
A	Flue gas temperature > 95°C	Check why flue gas becomes temperature > 95°C
E	Internal interlock fault	Reset the supply power by the on/off switch
H	Flow sensor > 105°C with burner on	Check system water flow
F	Too many ignition attempts	
O	Gas valve connection	Check short cut wire on print board terminal X4

## 4.12. Menu structure

By pressing the set/reset button in for longer than 5 seconds, you go to the 'mode' menu.

To change the subsequent "Letter" parameter, the user must press the Set/Reset button.

To change the "Range" setting in the parameter, the user must press the "+" or the "-" button.

Letter	Description	Range	Factory setting	Field of application
<b>C</b>	max. set point of central heating	25°C - 90°C	82°C	
<b>O</b>	Central heating post-running time	1 - 25 min, CO = 24 hours	5 min	
<b>P</b>	Max central heating capacity	33 – 100 %	80 %	
<b>H</b>	Type of application	<b>0</b> = central heating unit <b>1</b> = combi-unit (internal HWS cylinder) <b>2</b> = for external HWS cylinder 12kOhm <b>3</b> = for external HWS cylinder 10kOhm <b>4 and 5</b> = all functions are blocked	unit-dependent	unit-dependent
<b>d</b>	HWS temperature	40°C -65°C	60°C	Combi-unit
<b>t</b>	Hold temperature	40 - 50°C	40°C	
<b>b</b>	Set point for storage HWS cylinder	40°C -70°C	60°C	external storage vessel
<b>O/b</b>	Basic temperature External characteristic	10 -70°C	20°C	These three settings are only active when an external sensor is connected
<b>O/S</b>	Slope External characteristic	1-100	20	
<b>O/d</b>	Day reference temperature	0°C -70°C	20°C	
<b>r</b>	Factory setting	 = Factory setting  = Changed factory setting	If you switch back to the factory setting, this has no effect on the H, S and P/S settings	
<b>S</b>	Pump speed	00 = automatic  = always high  = always low	00 = automatic	
<b>P/S</b>	Maximum pressure jump	 = 0.54  = 0.53  = 0.52	 = 0.54	

In the View mode, you can read the actual values of:

**8** = Water pressure (in bar)

**1** = Flow temperature (in °C)

**2** = Return temperature (in °C)

**3** = Inlet cold water temperature / HWS sensor (in °C)

**4** = External temperature (in °C)

**5** = Outside temperature (in °C)

**6** = Flue gas temperature (in °C)

**7** = Flame signal (in µA DC)

**9** = Last interlock

**A** = Last blocking

**CHAPTER 5. TEMPERATURE REGULATIONS**

**5.1. CENTRAL HEATING**

The permissible central heating flow temperature can be set between 40°C and 90°C. The burner is blocked when the set flow temperature is reached. During the first 60 seconds of a central heating heat demand, the flow temperature may rise to 3°C above the set point before the regulation locks.

**5.1.1. Central heating temperature regulation with on/off thermostat without outside temperature sensor**

**Increasing set point**

When the room thermostat is closed (heat demand), the set point (desired central heating flow temperature) rises at a rate of 2°C per minute until the maximum permissible central heating flow temperature is reached (21 minutes from minimum 40°C to 82°C).

**Falling set point**

When the room thermostat is open (end of heat demand), the set point (desired central heating flow temperature) falls at a rate of 4°C per minute to the minimum central heating temperature (10.5 minutes from 82°C to minimum 40°C).

**Burner is on**

- when the room thermostat is closed (heat demand)
- and when the actual flow temperature is 5°C below the set point (desired central heating flow temperature)
- and after 3 minutes anti-reciprocital time, if applicable

**Burner is off**

- when the room thermostat is open (end of heat demand)
- when the actual flow temperature is 3°C above the set point (blocking)
- or when the actual flow temperature is 3°C above the maximum permissible central heating temperature.

*During the set central heating post-running time, the pump will continue to run over the central heating circuit in low load.*

**5.1.2. Central heating temperature regulation with on/off thermostat with outside temperature sensor**

**Set point**

*The desired central heating flow temperature (set point) is calculated on the basis of the measured outside temperature and the [O/S] - [O/d] - [O/b] parameters set in the menu.*

In formula form:

$$\text{Set point of central heating} = (20^\circ\text{C} - \text{outside temperature}) \cdot [\text{O/S}] / 10 + [\text{O/d}]$$

Letter in menu	Description	Range	Standard setting
O/b	Basic temperature	10 -70°C	20
O/S	Slope	1 – 100	20
O/d	Flow temperature at outside = 20°C	0 -70°C	20

**Heating curve**

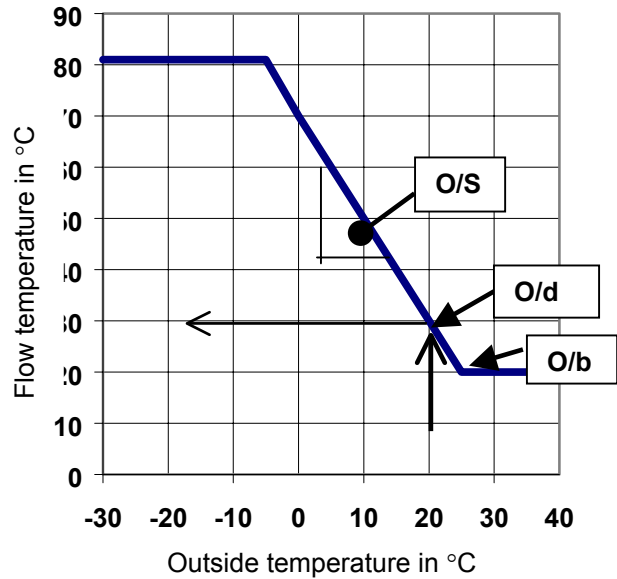

**O/b-value:** The setting of the minimal Heating flow temperature ( value in °C).

**O/S-value :** The setting for the sloop of the curve. ( change of Flow temperature depending on the change of the outside temperature).

**O/d-value :** The setting of the flow temperature at an outside temperature of 20°C ( value in °C).

**Parameter „C“**

The setting in the menu „C“ makes the maximal heating flow temperature ( default 82°C).

**Burner is on**

- when the room thermostat is closed (heat demand)
- and when the actual flow temperature is 5°C below the set point (desired central heating flow temperature)
- and after 3 minutes anti-reciprocital time, if applicable, after a reciprocital stop

**Burner is off**

- when the room thermostat is open (end of heat demand)
- when the actual flow temperature is 3°C above the set point (blocking)
- or when the actual flow temperature is 3°C above the maximum permissible central heating temperature.

*During the set central heating post-running time, the pump will continue to run over the central heating circuit in low load.*

**5.1.3. Central heating temperature regulation with modulating thermostat (EBV or Opentherm) with or without outside temperature sensor**

**Set point**

The set point indicates whether there is a heat demand.  
- Without an outside temperature sensor, the desired central heating flow temperature (set point) is calculated by the modulating room thermostat.

- With an outside temperature sensor, the measured outside temperature is sent to the modulating room thermostat, which uses it to calculate the desired central heating flow temperature (set point).

#### Burner is on

- when the room thermostat is closed (heat demand)
- and when the actual flow temperature is 5°C below the set point (desired central heating flow temperature)
- and after 3 minutes anti-recycling time, if applicable

#### Burner is off

- when the room thermostat is open (end of heat demand)
- when the actual flow temperature is 3°C above the set point (blocking)
- or when the actual flow temperature is 3°C above the maximum permissible central heating temperature.

During the set central heating post-running time, the pump will continue to run over the central heating circuit in low load.

## 5.2. HWS temperature regulations

### 5.2.1. Combi-boiler

*HWS heat demand always has priority over central heating heat demand.*

#### 5.2.1.1. HWS heat demand

There is demand for hot water when running a shower or bath, etc.

#### 5.2.1.2. End of hot water heat demand

There is end of hot water heat demand when the tap is shut off and the user stops running water for a shower or bath, etc.

#### 5.2.1.3. Store heat demand

There is store heat demand when the internal HWS cylinder sensor falls below the desired HWS store temperature.

#### 5.2.1.4. End of store heat demand

There is end of store heat demand when the water temperature has reached the set hot water temperature or when the minimum hold temperature (the greater of the two) is reached.

*Note: After the end of the HWS heat demand or the store heat demand, the store heat demand is blocked for 45 minutes.*

#### Burner is on

- when the cold water sensor does not cool by more than 2°C /10 s
- and when the return temperature is lower than the desired HWS temperature + 5°C;
- and when the return temperature is lower than the desired HWS temperature +35°C;
- and when the flow temperature is lower than 93°.

*Note: The pump runs for the internal HWS cylinder at the highest speed.*

#### Burner is off

- When the return temperature is 2°C above the desired HWS temperature and the cold water sensor has measured a rise of 0.2°C/10 s
- or when the flow temperature is above the desired HWS temperature + 40°C;
- or when the flow temperature is above 93°C;

- also when the cold water sensor is above the set HWS temperature.

*Note: The pump continues to run 30 seconds after the internal HWS cylinder is satisfied*

### 5.2.2. Boiler with external HWS cylinder

The regulation is made on the basis of flow temperature with a normal cylinder thermostat function, on off.

#### 5.2.2.1. HWS cylinder with external sensor without modulating space unit

The unit switches the heating of the storage HWS cylinder off when the return sensor has reached the desired final temperature of the HWS cylinder.

There is a burner demand when the flow temperature is lower than 85°C and the return temperature is lower than the desired HWS cylinder temperature.

*With HWS cylinder heat demand, the pump state is high.*

#### 5.2.2.2. HWS cylinder with external sensor with modulating space unit

The modulating thermostat will generate a desired HWS temperature value.

The unit switches the heating of the cylinder off when the return sensor has reached the desired final temperature of the HWS cylinder.

There is burner demand when the flow temperature is lower than 85°C and the return temperature is lower than the desired HWS cylinder temperature.

*With HWS cylinder heat demand, the pump state is high.*

#### 5.2.3. HWS cylinder with thermostat without modulating space unit

There is HWS cylinder heat demand when the HWS cylinder thermostat is closed.

The unit switches the heating of the HWS cylinder off when the return sensor has reached the desired final temperature of the HWS cylinder

There is burner demand when the flow temperature is lower than 85°C and the return temperature is lower than the desired HWS cylinder temperature.

*With HWS cylinder heat demand, the pump state is high.*

#### 5.2.4. HWS cylinder with thermostat with modulating space unit

The modulating thermostat will generate a desired hot water temperature value.

There is heat demand when the HWS cylinder thermostat is closed.

The unit switches the heating of the HWS cylinder off when the return sensor has reached the desired final temperature of the HWS cylinder.

There is burner demand when the flow temperature is lower than 85°C and the return temperature is lower than the desired HWS cylinder temperature.

*With HWS cylinder heat demand, the pump state is high.*

## CHAPTER 6. BURNER STATES and MONITORING

### 6.1. Burner states

#### 6.1.1. Rest state

*Fan off - Gas valve off - Igniter off - Ionisation off*

During the rest state, a check is made to see if there is burner demand.

If a false flame signal is detected during the rest state for more than 5 seconds, the Manager locks. If the glow plug counter is too high (too many Starts), the regulation blocks the burner demand.

If there is burner demand and no blocking, the system will go over to purging/preheating.

#### 6.1.2. Purging/Prestart

*Fan off - Gas valve off - Igniter off - Ionisation off*

The fan is switched on at the desired purging speed. The glow plug is switched on at the same time as the fan.

After a few seconds, the fan goes from purging speed to the faster ignition speed.

If a false flame signal is detected during purging, the regulation locks.

If this lock is present for more than 5 seconds, the regulation locks with '8':

#### 6.1.3. Ignition

*Fan on - Gas valve on - Igniter on/off - Ionisation off/on*

The fan is running at the ignition speed.

The gas valve is activated.

The Glow plug will be switched off as soon as an ionisation signal is measured.

If there is no ionisation at the end of the safety time, a new attempt at ignition will be made if this was not the last permitted attempt at starting. Here, there will first be post-ignition failure ventilation see 8.5.

If there is ionisation at the end of the safety time, the system continues with operation:

#### 6.1.4. Operation

*Fan off - Gas valve off - Igniter off - Ionisation on*

The fan is running at the required modulation speed.

If the ionisation fails, a restart is made, providing this is not the third time within the burner demand. If this is the third time, the Manager will lock.

The restart runs through post-ventilation purge, see 8.5.

If the burner demand ends, the system goes to post-ventilation purge, see 8.5.

#### 6.1.5. Post-ventilation

*Fan on - Gas valve off - Igniter off - Ionisation off*

The fan runs at the last demanded speed if the post-ventilation is running at the end of the burner demand and in all other cases at the highest speed.

If a false flame signal is detected during purging, the regulation locks.

If this lock is present for more than 5 seconds, the regulation locks with '?':

With end of post-ventilation purging after the end of the burner demand, a start test is run through:

#### 6.1.6. Functional locking

*Fan on/off - Gas valve off - Igniter off - Ionisation off - Alarm contact on*

During functional locking, the pump is on the central heating circuit.

At the beginning of the interlock, in the fault table is updated. With some instances of interlock, the fan will post-ventilate for 1 minute at 50% of the maximum speed.

### 6.2. Monitoring

#### 6.2.1. Monitoring the pump circulation

The pump is switched off for 3 seconds for each burner start.

At the same time, the purging/prestart time starts. The static pressure is measured. After this, the pump is switched to a high speed. The purging time starts as soon as the pump speed has reached the desired value. At the end of the purging/prestart time, the active pump pressure is measured. If the difference between the active and the static pump pressure is less than 0.05 bar, the regulation locks and goes to the pump test program.

If the difference is more than 0.54 bar, the regulation locks and goes to the pump test program.

If the difference is between 0.05 and 0.54 bar, the ignition time starts.

When the pump is switched to the low state during ignition, the pressure increase monitoring is switched off.

After the ignition time, the flow monitoring is realised by the flow/return sensor.

If the temperature rise is large enough, the pump modulation is released.

If the pressure changes afterwards by more than  $\pm 0.1$  bar ( $\pm 0.27$  bar with changing pump speed) within 4 seconds, the regulation will block and switch over to the pump test program.

With switching over from central heating to hot water during operation, the pressure fluctuation detection is defeated for 16 seconds.

#### 6.2.2. Pump program

If the temperature difference between flow and return is greater than 30°C, the pump switches to a high speed. When the temperature difference drops below 10°C again, the pump switches back to a low speed.

If the pump is on for a HWS demand with a Combi-unit or for cylinder heat demand, the pump is continuously at high.

#### 6.2.3. Pump test program

The pump is switched off for 15 seconds and high for 15 seconds. The display shows 'P'.

The initial pressure is measured before the pump is switched on. The test pressure is measured 3 seconds after the pump is switched on. If the difference between these two pressures is greater than 0.20 bar and less than 0.54 bar, the pump test is finished.



**6.2.4. Static pressure monitoring**

If the water pressure is less than 0.2 bar, the regulation locks with a 'P' + 'pressure' on the display.

This lock is removed when the water pressure goes above 1.3 bar.

With a water pressure between 0.5 and 0.2 bar, the burner is limited to low load.

The display shows alternately the 'P' and the normal status display.

If the water pressure is greater than 3.5 bar, the regulation locks with a 'P' + 'pressure' on the display.

The display shows alternately the 'P' and the normal status display.

If the water pressure is greater than 3.5 bar, the regulation locks with a 'P' + 'pressure' on the display.

This lock is removed when the water pressure goes below 3 bar.

**6.2.5. Difference in temperature**

If the temperature difference between flow and return is greater than 45°C, the regulation locks. The lock is removed with a difference of less than 20°C.

If the temperature difference between flow and return is less than -5°C, the regulation will lock immediately during central heating and 20 seconds after ignition during tapping.

**6.2.6. Maximum temperature limitation**

If the flow temperature goes above 105°C, when the burner is off, the regulation will lock with a continuous 'H' (hysteresis 5°C).

If the flow temperature goes above 105°C, when the burner is on, the regulation will lock with a flashing 'H'. Only a reset will remove the interlock.

If the flow or return temperature goes above 97°C, the regulation will lock.

**6.2.7. Flue gas temperature limitation**

If, after switching the supply voltage on, a flue gas temperature of greater than -25°C is measured, the flue gas sensor is present. If a temperature below -25°C is measured afterwards, the regulation locks with the message flue gas sensor interruption ('4').

If the flue gas temperature goes above 80°C, the burner is limited to low load.

If the flue gas temperature goes above 90°C, the regulation locks with 'A'.

If the flue gas temperature goes below 70°C, both locks are removed.

If the flue gas temperature goes above 95°C, the regulation locks with 'A'.

**6.2.8. Flow sensor protection**

The difference between flow and return temperatures must be less than 20°C before each burner start. The difference between flow and return temperatures must be raised by 3°C within 10 seconds after each burner start. However, if the difference is less than the previous temperature difference, the burner is started again after 10 seconds.

During this time, the capacity supplied by one of the hot water Combi-boilers during tapping is the desired capacity and in all other cases the initial capacity.

If the difference is not detected, the regulation locks with a 'P'.

This lock is removed when the flow temperature goes below 65°C and the minimum locking time (30 s) has elapsed.

If this lock occurs more than three times within a heat demand, the regulation locks with '1'.

If the difference between flow and return temperatures becomes less than -5°C during burning, the regulation locks.

Once per hour, if there is no heat demand, the difference between flow and return temperatures must be less than ± 5°C. If this is not the case, the pump will be switched on and a check will be made for a maximum of 10 minutes to see whether the temperature difference goes to within ± 5°C.

**6.2.9. Frost protection**

When the flow temperature goes below 8°C (if there is no heat demand), the pump goes over to the central heating circuit and the display shows 'o'.

If the flow temperature goes below 3°C, the burner goes to low load.

When the return temperature goes above 15°C, the frost protection is finished.

When an external sensor is connected and the outside temperature goes below -4°C, the pump goes to central heating. This situation is removed at an outside temperature of -2 °C.

**6.2.10. Monitoring the fan speed**

When the measured fan speed deviates from the desired speed, this is masked in operation for 10 seconds. After these 10 seconds, the burner will go out of operation and the post-ventilation program will be performed.

When the measured fan speed deviates from the desired speed during pre- or post-ventilation, the regulation locks. If this lock lasts for longer than 60 seconds, the regulation locks with '5'.

When the measured fan speed goes above a maximum value during the rest state, the regulation locks. If this lock lasts for longer than 60 seconds, the regulation locks with '5'.

**6.2.11. Glow plug protection**

The glow plug protection counter is incremented at each ignition. This counter is decremented per minute. If this counter is too high, the burner demand is blocked.

**CHAPTER 7. MAINTENANCE**

**High voltage !!**



The wiring of the pump, the three-way valve, fan and wiring of the gas block can be under a voltage of 230 VAC.

**Serial connection**



A PC or Laptop can be connected for an extensive diagnosis and display of the functionality. The necessary cable (which contains an electrical isolation) and software can be ordered as options.

**7.1. ANNUAL MAINTENANCE**

After the first year, have a recognised installer or maintenance man inspect the unit. He can ascertain the maintenance deadline on the basis of the inspection and circumstances. A certified (SCIOS) installer should inspect the unit annually.

**7.1.1. Checking the CO<sub>2</sub> percentage on full load**



The nominal value for natural gas at full load is 8.8% CO<sub>2</sub>.

The unit does not need to be cleaned if the measured CO<sub>2</sub> percentage at full load is within 8.8% CO<sub>2</sub> and 9.4% CO<sub>2</sub>.

**7.1.2. Measuring the load on the unit**

A load drop can be the consequence of a clogged flue gas channel or a clogged air intake channel. Check whether this is the case by measuring the load on the unit. First set the central heating capacity "P" to 100% in the menu. Let on the unit burn on chimney sweeper function at full load. Measure the gas consumption. If the ascertained deviation in load is no more than 15% of the nominal value, the flue gases can be sufficiently exhausted and there is no clogging. At the end of the check, reset the central heating capacity "P" in the menu to its customer-specific value.



If the ascertained deviation in load is no more than 15% of the nominal value, the flue gases can be sufficiently exhausted and there is no clogging. At the end of the check, reset the central heating capacity "P" in the menu to its customer-specific value.

**7.1.3. Checking the condensation water drain**



There is an opening for this purpose on the top of the vapour tray. First remove the rubber sealing plug; rinse the vapour tray and drain with clean tap water. When no more impurities are removed, the vapour tray is clean. Also clean the trap.

**7.1.4. Ionisation probe**

The ionisation probe is a part that wears. An insulating layer can be formed in the flame at high temperature. This layer can be removed with fine sandpaper. Do not clean the ionisation probe with coarse sandpaper, because grooves in the surface of the pin will accelerate the formation of the layer.



**Full load:**

Correct ionisation current between 6 µA DC to 13 µA DC.

**Low load:**

Correct ionisation current between 3µA DC to 13 µA DC.

Unplug the plug of the ionisation probe (low voltage). Remove the two screws from the ionisation clamp. Remove the ionisation probe from the cover and check the ionisation probe. The ionisation probe must be straight and clean (a slight deposit is normal), Clean or replace the ionisation probe.

**7.1.5. Water pressure**

Check the water pressure; top up and de-aerate as necessary. Press the 'plus' button in for at least 5 seconds to see the actual water pressure in bar on the display. Press briefly on the 'min' button to return to operational mode.

## CHAPTER 8. MALFUNCTIONS

### High voltage!

The wiring of the pump, the three-way valve, fan and wiring of the gas control can be under a voltage of 230 VAC.

#### 8.1. Draining the unit

- On the central heating side: Switch the unit off and open the filling tap.
- On the HWS side: Switch the unit off. Shut the inlet combination off. Open a hot water tap and the protection device of the inlet combination.

When using the group of taps (see the accessory list), it is possible to only tap the unit. Proceed as follows:

- Switch the unit off.
- Close all taps under the unit.
- Close the inlet combination
- Open the filling tap under the unit.
- Open a hot water tap.
- Open the protection device in the unit and of the inlet combination.

#### 8.2. No signal on the display



If there is no signal on the display, check if the mains voltage of 230 VAC is present on the unit.

There must be voltage of 230 V on the live connection "L" and no voltage on the neutral connection "N".

Check whether the on/off switch on the bottom of the unit is switched on.

Check the glass fuse on the printed circuit board Careful, high voltage! The fuse is placed on the printed circuit board in the 230 V circuit. So first disconnect the unit mains!

#### 8.3. Fault code 'U/d or U/O' (alternating U with a status code will appear on the display)

This fault code occurs when the Live and Neutral are exchanged or when no Earth is present.

Reverse the plug so that the Live is connected to Live and Neutral to Neutral.

#### 8.4. Unit does not respond to central heating heat demand

Is the parameter for the type of unit correctly set in the menu?

- **Parameter H = 4** is not active ( no heating).
- **Parameter H = 5** is not active ( no heating).

Check for correct assembly and/or cable fracture of the wiring of the room thermostat (terminals 1 and 2) of the terminal block) and, if applicable, the external sensor (terminals 5 and 6) of the connection to the building management system (terminals 3 and 4).

#### 8.5. Unit does not respond to HWS demand

Is the parameter for the type of unit correctly set in the menu?

- **Parameter H = 1** is for a Combi-unit.
- **Parameter H = 2** is for a boiler suited for a storage vessel with a sensor of 12 kOhm.
- **Parameter H = 3** is for a boiler suited for a storage vessel with a sensor of 10 kOhm.
- **Parameter H = 4** is not active ( no HWS).
- **Parameter H = 5** is not active ( no HWS).

Check the HWS sensor (NTC) and its wiring.

Check the three-way valve for function and check the wiring.

#### 8.6. Three-way- diverter valve

Check whether the actuator stops on the switch in position correctly.



##### Position far side

In this central heating position the spring is powered.



##### Position near side

In this HWS-position with the spring unloaded.

#### 8.7. Check function of gas control



Open the outlet pressure measurement nipple of the gas control

- connect the pressure meter to the outlet pressure measurement nipple
- measure the pressure (this must be zero)
- start the unit.
- the unit will now be rinsed at 1500 rpm
- next, the fan starts at the initial speed of 3000 rpm.
- the pressure meter will now indicate an underpressure of approximately 3 mbar
- when the gas control is opened, the zero pressure regulator will again make zero pressure.
- if not, then the gas control is not functioning.

#### 8.8. Measuring the fan impedance

Check the resistance of the coil, the two outermost contacts on the fan motor.



The value that the multimeter shows must be between 115 and 120 Ohms at room temperature.

If the fan is defective, the drive on the drive on the Manager may also be damaged.

#### 8.9. Fitting instructions for the pressure sensor

The seal is made with an "O"-ring. The pressure sensor must only be tightened slightly more than hand tight.

### 8.10. Fitting instructions for the safety valve



The safety valve must be tightened with a torque of 10 Nm.

### 8.11. Malfunction code 'F' (flashing)

After three failed attempts in a row, the unit will lock (flashing 'F').

This can have very different causes:

- no gas
- no ignition
- bad flame formation
- bad ionisation current

#### 8.11.1. Gas control will not open (no voltage)

(Careful !!! 210 VDC).

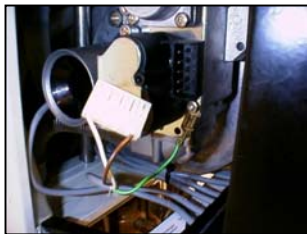

If the gas control is not connected, the Manager will see this at the beginning of the heat demand as a malfunction and therefore lock.

To measure the voltage on the gas control, the gas control must remain connected.

During the starting period, the gas control is connected to a voltage of 210 VDC.

#### 8.11.2. Gas control will not open (gas inlet pressure too high)



The gas pressure in the gas pipe before the gas control is too high. The safety valves of the gas control cannot open with gas pressures of >60 mbar.

- open the inlet pressure measurement nipple of the gas control
- connect the pressure meter
- measure the gas pressure (10 - 50 mbar)

#### 8.11.3. Gas control will not open (coils defective)



The electrical coils of the gas control are burnt out and the safety valves of the gas control will therefore not open.

- The two outermost contacts on the gas valve should be measured for resistance
- the value that the multimeter shows should be about 4.1 kOhm at ambient temperature.

### 8.11.4. Gas/air mixture is not correctly adjusted

see Chapter 4. : Adjustment full load and low load.

### 8.11.5. Check glow plug

The 230 volt glow plug is in order if the measured resistance at room temperature is about 1.0 - 1.4 kOhm.

- remove the connection of the glow plug (230 V)
- connect a multimeter
- measure the resistance

### Replacing the glow plug



The glow plug is a resistance through which current is fed.

As a result of the high temperature of the glow plug, the burner can be ignited. This makes the glow plug a part that wears. The average life of the glow plug is estimated at 8 years, depending on the number of starts and on the variation of the mains voltage.

- remove plug from glow plug (230 V high voltage)
- remove glow plug from cover of unit
- replace glow plug

### 8.11.6. Check ionisation current



Direct measurement of the ionisation current using a multimeter ( $\mu\text{A DC}$ ).



When the unit burns on chimney sweeper function, the ionisation current can be read directly on the display.

- Ionisation current in full load is correct between 6  $\mu\text{A DC}$  to 13  $\mu\text{A DC}$ .
- Ionisation current in low load is right 3  $\mu\text{A DC}$  to 13  $\mu\text{A DC}$ .

### Insulating layer



With high temperature flame, an insulating layer can be formed on the probe. This layer can be simply removed with fine sandpaper. However, coarse grooves in the surface of the pin will accelerate new formation of the layer.

### 8.11.7. Inspection / cleaning / replacement of the ionisation probe



- unplug the plug of the ionisation probe (low voltage).
- remove the two screws from the ionisation clamp.
- remove the ionisation probe from the lid of the unit.
- check the ionisation probe.
- the ionisation probe must be straight and clean (a slight deposit is normal).
- clean or replace the ionisation probe.

### 8.11.8. Ionisation probe or ionisation cable makes short circuit with earth

The negatively charged ions created by the burner form the ionisation current to earth. if there is short circuit to earth, the Manager cannot measure any current.  
Repair short circuit.

## USER MANUAL

### General

The unit combines a maximum of comfort with an extremely easy operation.

As the user, you need do no more than set the desired temperature on the room thermostat, no matter what time of the year.

Depending on how much you value optimum comfort and the lowest possible energy consumption, the following tips can help you make optimum use of your unit:

To help limit the energy consumption, it is recommended to set the room thermostat to a lower temperature a few hours before going to bed.

Turn all radiator taps fully open in the rooms that you want to heat.

Shut the radiator taps off in the rooms where you do not want any heating.

### Cleaning the unit

Regularly clean the outside of the unit with a soft, damp cloth. It is not necessary to shut the gas tap off or switch the mains off for this.

Never use aggressive or flammable cleaning agents.

Take note that the pipes can be at a high temperature.

### Holidays

With long-term absence, for example in the holidays, it is recommended to leave the unit continually switched on. The reason is that the unit makes a number of checks every 24 hours.

If frost can be excluded, set the room thermostat to a lower temperature.

If frost cannot be excluded, set the room thermostat to a temperature of 12°C or higher.

Although the unit has an internal frost protection, this does not protect the whole installation against freezing.

### Brrrr, the central heating is not working

In the unlike event that the central heating has let you down, we have some tips for things that you can check and remedy yourself before an installer.

The central heating boiler is a fairly complicated item that is fitted with safety devices, which prevent a dangerous situation. There can be many reasons why the central heating is not working.



### Electricity and gas

Is the connection of the green block in the green socket correct connected?

Is the main switch on the unit in the right position?

Or is the circuit to which the boiler is connected out of operation because the fuse has blown or the earth leakage switch has activated?

Is there an (unusual) interruption in the gas supply? Check by seeing whether a gas cooker in the kitchen is working. If it is now working, call the gas company. The gas flow can also be blocked because the gas filter of the boiler is contaminated; this is a problem for the service man.

The unit also lets the pump regularly run outside the heating season to prevent it from sticking. If the mains supply outside is interrupted several times during the heating season, the pump can stick. Solution: turn the shaft of the pump a few times by hand (screwdriver).

### Water and air

If the water pressure in the installation falls below a minimum level, the burner will be off.

Solution: Top up with water.

It is possible to read the water pressure directly from the display.

Reading: Press the + button in for a minimum of 5 seconds.

From the menu back to normal operation: Press the - button in briefly (or automatically after about 5 minutes).

During filling, the unit must be connected to the mains and be switched on.

Fully open all radiator taps.

Connect the water supply to the filling connection of the installation.

Open the tap to fill the system with water.

When the water pressure is sufficient (> 1.3 bar), close the filling tap again.

If there is air in the installation, the boiler can switch on, but the radiators remain cold.

Follow the instructions from the manufacturer/installer for the venting of possible other elements of the heating installation, such as floor heating.

Fully open all radiator taps.

Vent the radiators after the pump is switched off.

Open the air bleed cocks of the radiators one at a time. Use an air bleed key for this.

As soon as water comes out of the air bleed cock, shut the cock off again.

If the central heating boiler is at the highest point of the installation, air can collect in the boiler. This can cause a malfunction in the boiler. Also vent the internal tap pot (only with a Combi-unit).

### Other causes

There must be heat demand from the room thermostat or other control, otherwise the boiler will not switch on. Set the thermostat to demand heat and check whether the boiler switches on; this can take a minute or so.

If there is little water circulation because too many radiator taps are closed, the boiler will not function or will function insufficiently. In this case, open more radiator taps or ask your installer to fit a bypass valve.

## Display



Open the cover in front of the display to be able to read the codes.

The display consists of three 7-segment LED's + three decimal points and three pushbuttons.

The left 7-segment LED shows the status or the menu step.

The two right 7-segment LED's show the temperature, the pressure or the parameter value.

Furthermore, the display has three buttons:

- "Set/Reset button"
- "- button"
- "+ button"

### Reset button

This is to rest the unit, should it be locked by a malfunction. The user must use button. The installer should only be called when the same malfunction occurs repeatedly.

### Abbreviated display indications

Display during normal operation (permanent)	
O	No heat demand, stand-by
C	Central heating heat demand, burner off
C.	Central heating heat demand, burner on
P/C.	Central heating heat demand, low load water pressure
c	Central heating pump post-running
d	Heat HWS, burner off
d.	Heat HWS, burner on
b	Heat external storage vessel, burner off
b.	Heat external storage vessel, burner on
o	Frost protection, burner off
o.	Frost protection, burner on

Display of blocks (permanent)	
1	Flow sensor interrupted
1.	Flow sensor short circuited
2	Return sensor interrupted
2.	Return sensor short circuited
4	Flue gas sensor interrupted
6	Cold water sensor interrupted
6.	Cold water sensor short circuited
A	Flue gas temperature > 80°C
H	Flow sensor > 105°C
E	Internal blocking fault
P	Pump test / Start function blocking / Water pressure
nc	Burner Manager fault (can only be reset by switching voltage on/off)

Display of locks (flashing)	
1	Flow/Return sensor fault
2	Too many restarts
3	Internal regulation fault / A/D conversion fault / external sensor fault
5	Fan fault
7	Gas valve fault
8	Flame detected with closed gas valve
A	Flue gas temperature > 95°C
E	Internal interlock fault
H	Flow sensor > 105°C with burner on
F	Too many ignition attempts
<b>An interlock (flashing) can only be unlocked by pressing the set/reset button.</b>	

**2003 Atmos Heating Systems Ltd.**

All rights reserved.

Nothing from this document may be duplicated and/or made public by means of printing, photocopy, microfilm or in any other way without prior written permission from the manufacturer. This also applies to the appropriate drawings and/or diagrams.

The information supplied in this document is based on general data with regard to constructions, material characteristics and working methods known at the time of going to print. Therefore, we reserve the right to make changes without notification. For this reason, the instructions given serve only as a guideline for the installation, use and maintenance of the unit shown on the cover of this document.

This document is valid for the unit in its standard version. Therefore, the manufacturer cannot be held liable for any damage arising from specifications that deviate from the standard version of the unit delivered to you.

This document has been compiled with all possible care. However, the manufacturer cannot be held liable for any mistakes in this document or for any consequences.

**Take the time to read this document carefully before installing or using the unit. Always keep this document near the unit.**

**Atmos Heating Systems Ltd.**  
**West March, London Road**  
**NN14SA Daventry**  
**Tel:**  
**Fax:**