

EuroCombi



ARISTON



A/23 MFFI - A/27 MFFI

G.C.N. 47-116-18 / 47-116-19

**Servicing Instructions
Type C Boilers**

**LEAVE THESE INSTRUCTIONS
ADJACENT TO THE GAS METER**



1. *SERVICING INSTRUCTIONS*

1.1 Replacement of Parts	3
1.2 To Gain General Access	
- Removing the Front Panel	3
- Removing the Side Panels	4
- To Lower the Control Panel	4
1.3 Access to the Combustion Chamber	
- Removing the Sealed Combustion Chamber	5
- Removing the Burner and Injectors	5
- Removing the Electrodes	6
- Removing the Main Heat Exchanger	7
- Removing the Air Pressure Switch	7
- Removing the Venturi Device	8
- Removing the Fan	8
1.4 Servicing and Removal of the Gas Valve	
- Setting Gas Pressure	9
- Removing the Spark Ignitor	11
- Removing the Gas Valve	12
1.5 Access to the Hydraulic Circuit	
- Removing the D.H.W. (Secondary) Exchanger	12
- Removing the Safety Valve	13
- Removing the Automatic Air Vent	13
- Removing the Main Flow Circuit Switch	13
- Removing the Pump	14
- Removing the Pressure Gauge	14
- Removing the Expansion Vessel	15
- Removing the Overheat Thermostat	15
- Removing the Heating Temperature Sensor (N.T.C.)	15
1.6 Access to the Control System	
- Checking the Fuses	16
- Removing the Time Clock	16
- Removing the P.C.B.s	17

2. *FAULT FINDING*

2.1 Fault Finding Guide (Flow-chart)	18
2.2 Fault Finding Using the Total Check System	23

3. *ELECTRICAL DIAGRAMS*

3.1 Electrical Connection	24
3.2 Functional Flow Connection	25

4. <i>SHORT SPARE PARTS LIST</i>	26
----------------------------------	----

1. SERVICING INSTRUCTIONS

To ensure efficient safe operation, it is recommended that the boiler is serviced annually by a competent person.

Before starting any servicing work, ensure both the gas and electrical supplies to the boiler are isolated and the boiler is cool.

Before and after servicing, a combustion analysis should be made via the flue sampling point (please refer to the Installation Manual for further details).

After servicing, preliminary electrical system checks must be carried out to ensure electrical safety (i.e. polarity, earth continuity, resistance to earth and short circuit).

1.1 Replacement of Parts

The life of individual components vary and they will need servicing or replacing as and when faults develop.

The fault finding sequence chart in chapter 2 will help to locate which component is the cause of any malfunction, and instructions for removal, inspection and replacement of the individual parts are given in the following pages.

1.2 To Gain General Access

All testing and maintenance operations on the boiler require the control panel to be lowered. This will also require the removal of the casing.

To dismantle the front part of the casing, proceed as follows:

1. Remove screw "A" (see fig. 1.1);
2. Lift the front panel up and forward (see fig. 1.2).



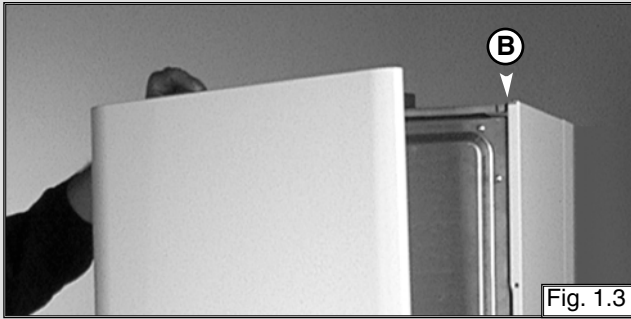

Fig. 1.3

Removing the side panels

1. Remove the screws "B";
2. Pull the panel away from the boiler, then lift the panel up and away from the boiler (see fig. 1.2).

To lower control panel

1. Remove the screws "B"
2. Push the two side panels outward slightly (fig. 1.5);
3. Rotate the control panel forward and down.

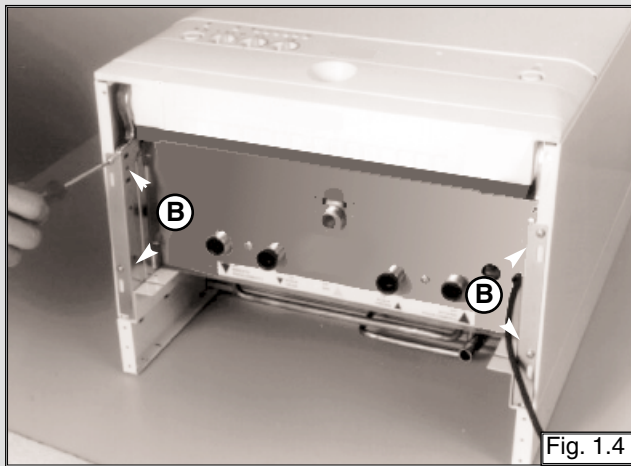

Fig. 1.4

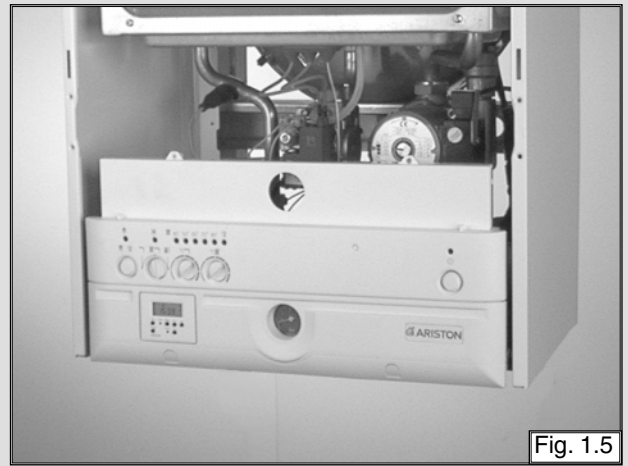

Fig. 1.5

To access the areas where the adjustment and control devices are located, simply remove the plugs by pressing from the inside, unscrew the screws "C" and remove the bottom part of the instrument panel, rotating it upwards.



Fig. 1.6

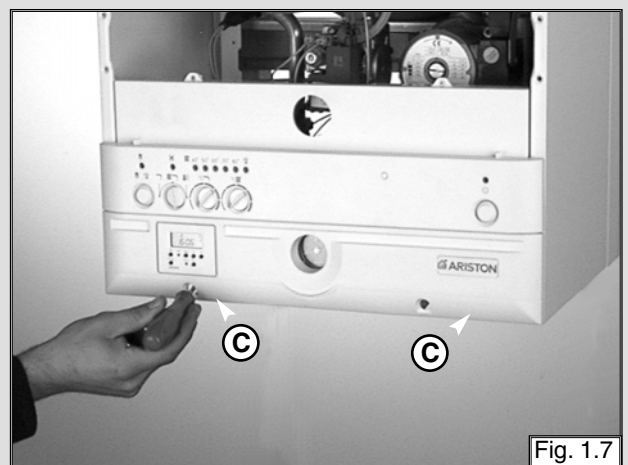
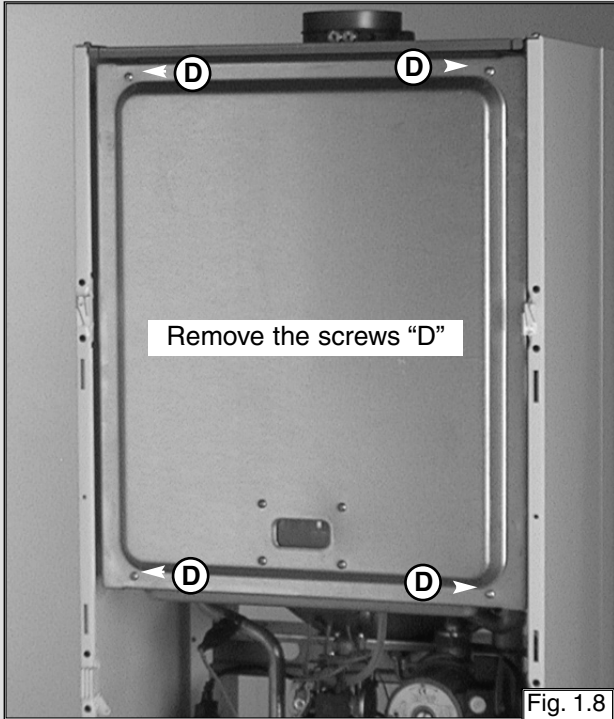

Fig. 1.7

1.3 Access to the Combustion Chamber

A/23 MFFI

Removing the sealed chamber frontal cover



Removing the combustion cover

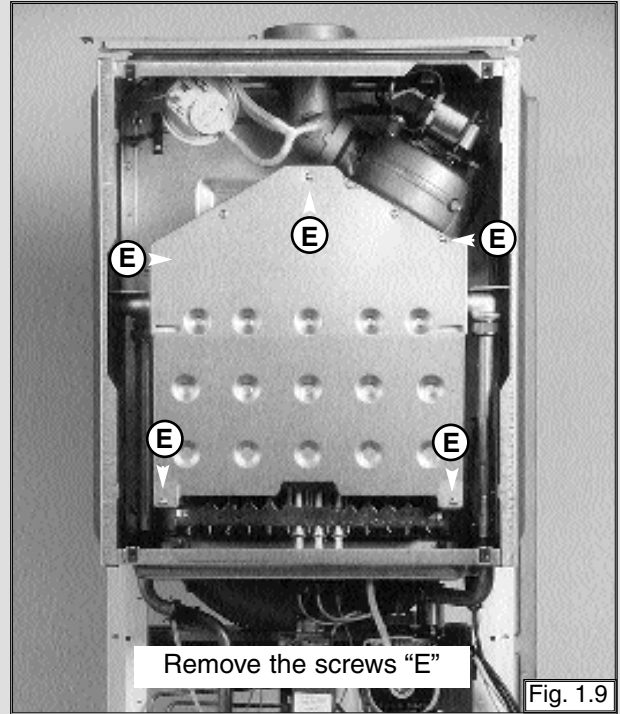

A/27 MFFI

Removing the sealed chamber frontal cover

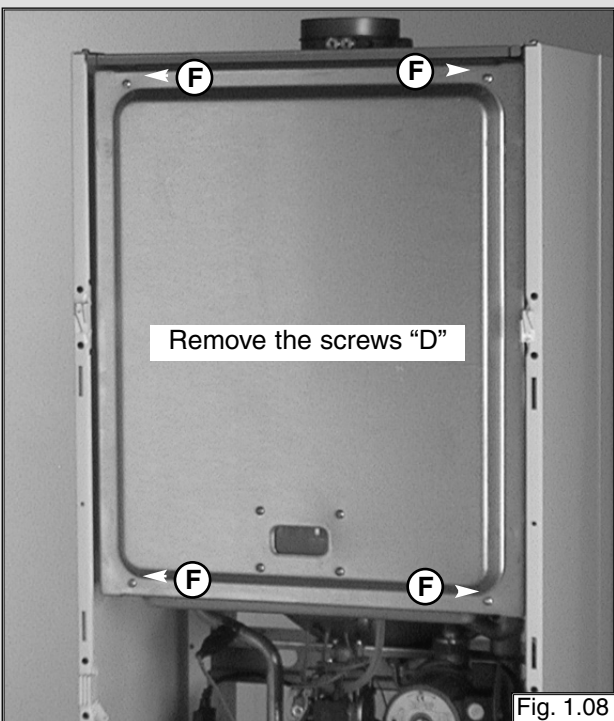

Removing the combustion cover

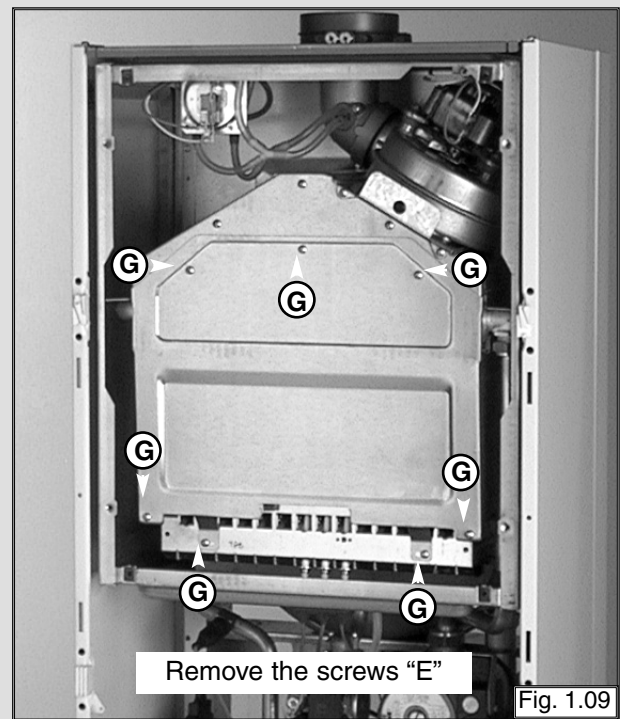

Removing the burner and the injectors

1. Remove the side panels of sealed chamber (*fig. 1.10*);
2. Remove the screws "H" of the burner (*see fig. 1.11*);
3. Remove the burner (*see fig. 1.12*);
4. Remove the injectors using a No. 7 socket spanner;
5. Replace in reverse order.

A/23 MFFI

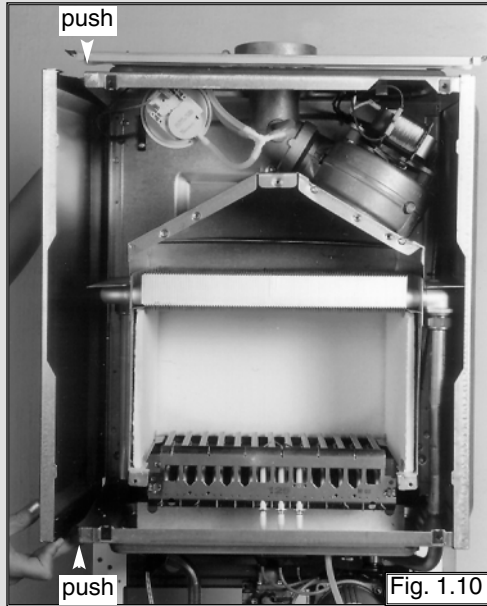

A/27 MFFI

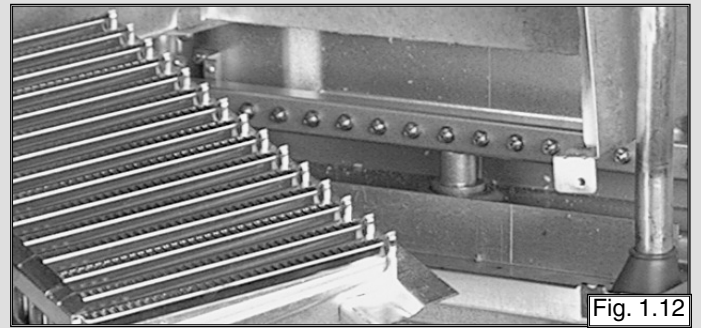
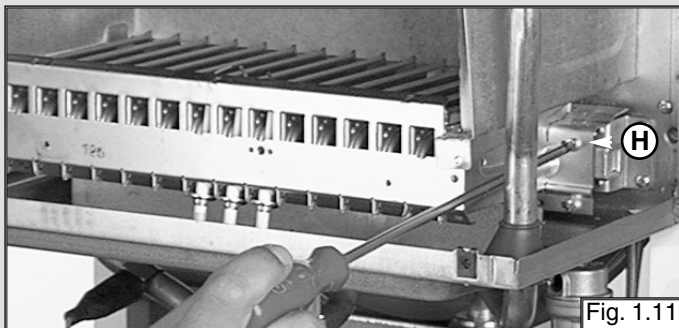
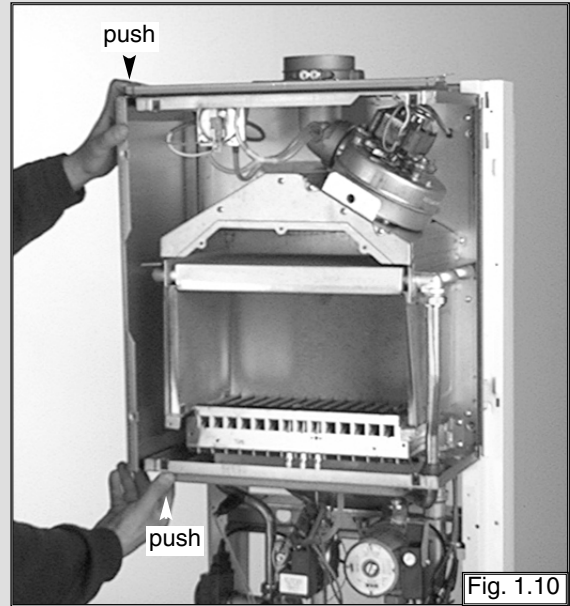

Removing the electrodes

1. Remove rubber gasket "I" (*see fig. 1.13*);
2. Disconnect ignition leads by pulling downward (*see fig. 1.14*);
3. To remove the flame sensor, disconnect the cable at its only connection point close to the P.C.B. (*see fig. 1.15*);

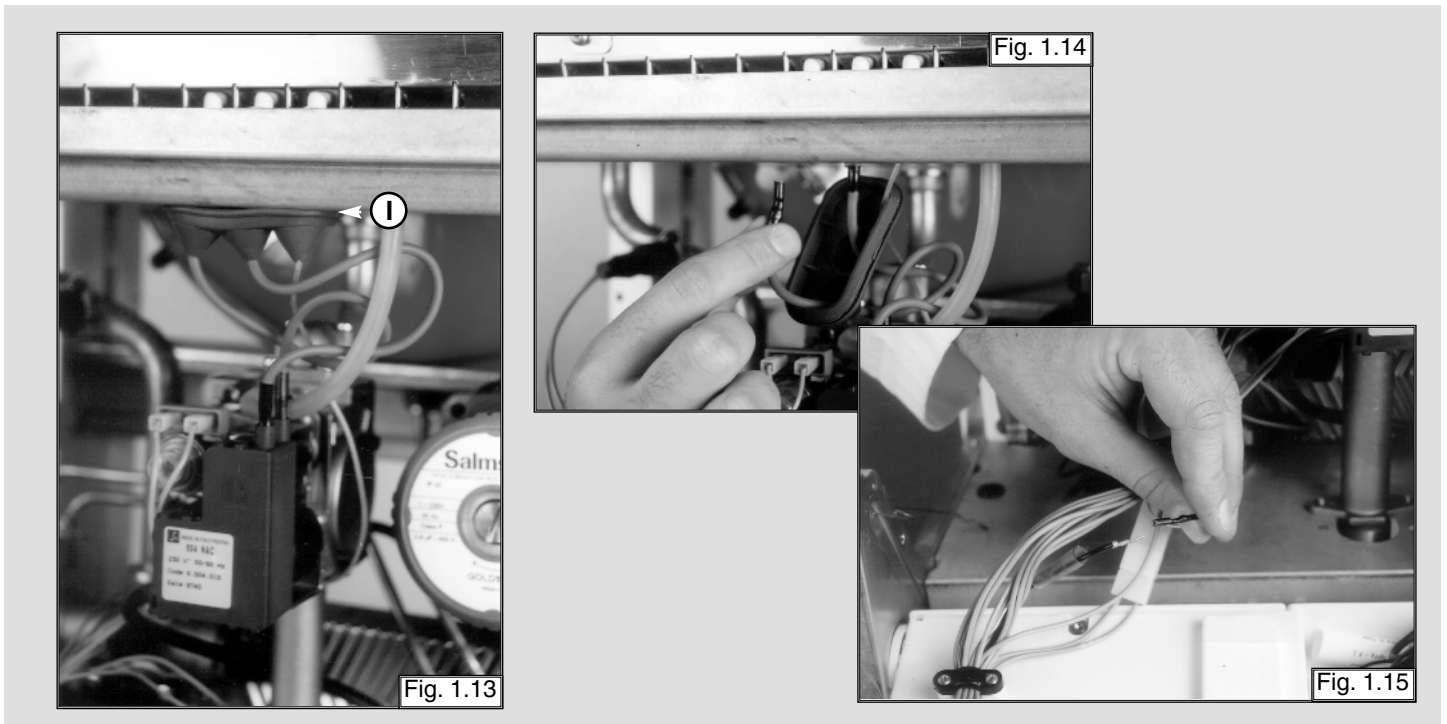

5. Remove screw "J" using a Philips No. 2 star tip screwdriver (*see fig. 1.16*);
6. Slide the electrode gently downward (*see fig. 1.17*).

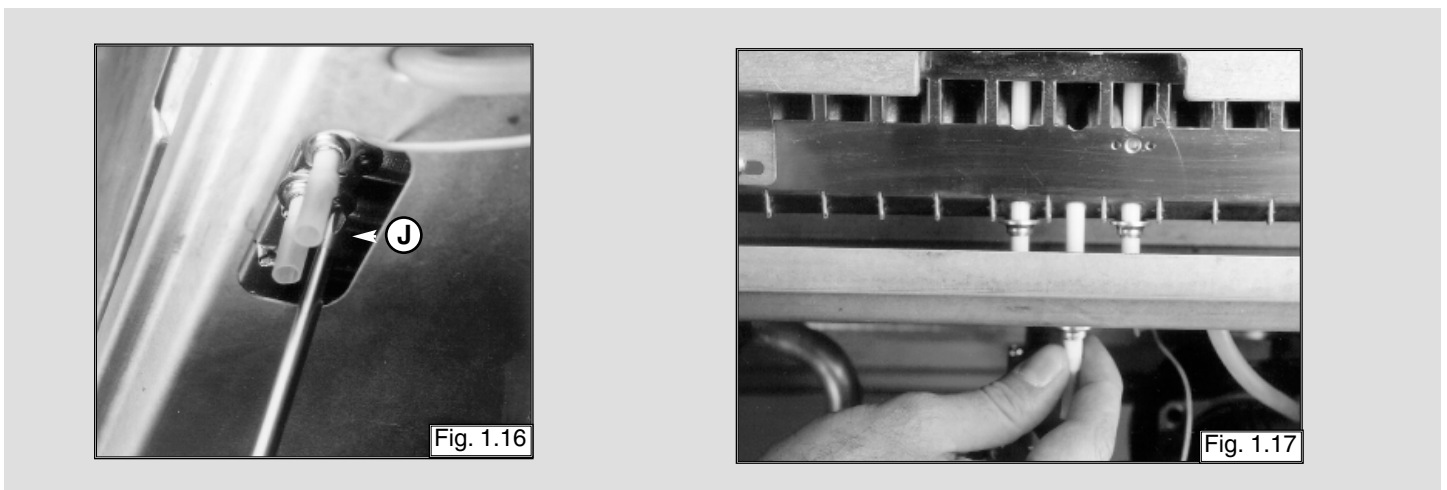

To replace, repeat the steps in reverse order, paying particular attention to the following:

- a - Centre the electrode in the positioning hole carefully, otherwise the electrode may break;
- b - Check that the cables have been connected correctly;
- c - Check that the rubber gasket covers the cable/electrode connection point completely.

Removing the main heat exchanger

1. Drain the boiler of water;
2. Release the two connection nuts "K" connecting the exchanger to the flow and return pipes (see fig. 1.18);
3. Pull it straight out (see fig. 1.19).

A/23 MFFI

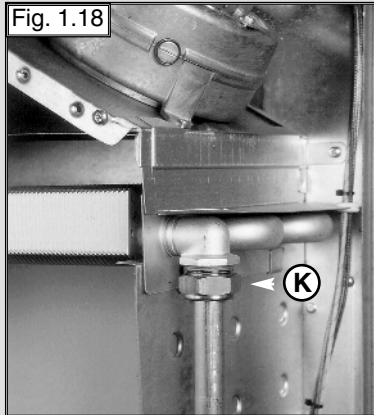

A/27 MFFI

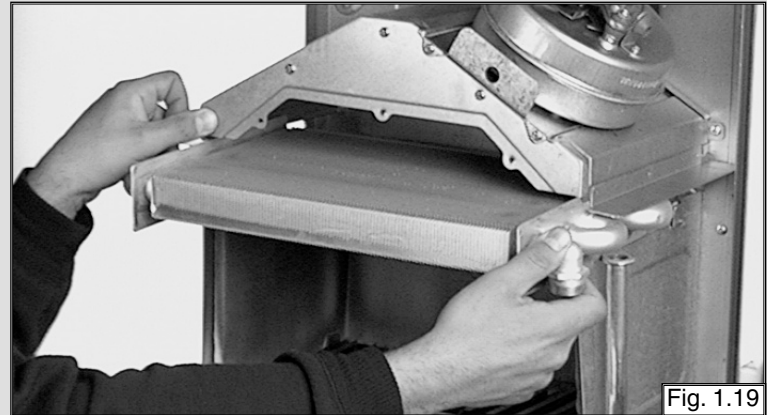
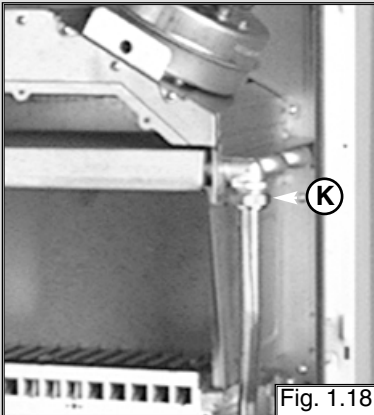

Removing the air pressure switch

1. Disconnect the electrical connections "L" and silicone pipes "M" from their connection points (see fig. 1.20);
2. Remove screws "N" on the top of the sealed chamber (see fig. 1.21); Use a No. 2 star tip screwdriver to remove the switch from the plate.

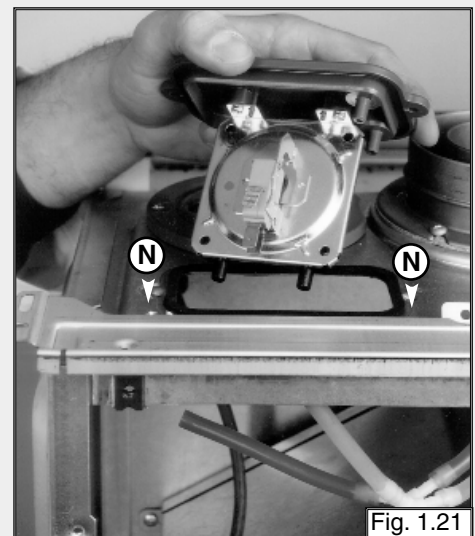
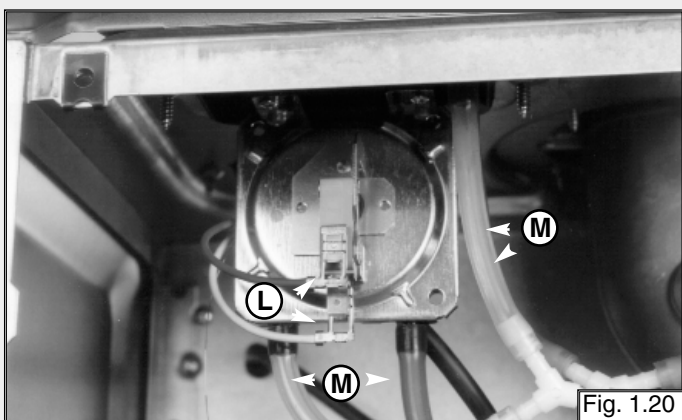

Removing the venturi device

1. Disconnect the silicone pipes "O" and remove the screw "P" (see fig. 1.22);
2. Extract the venturi (see fig. 1.23).

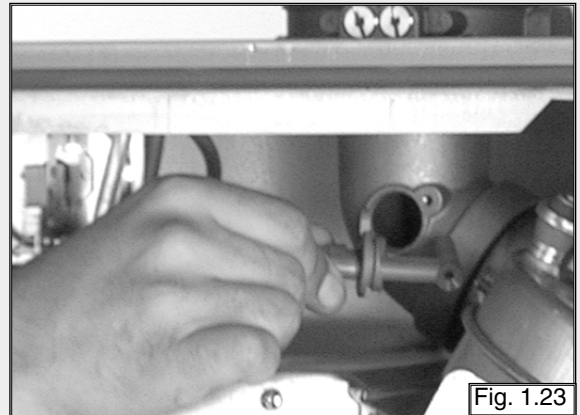
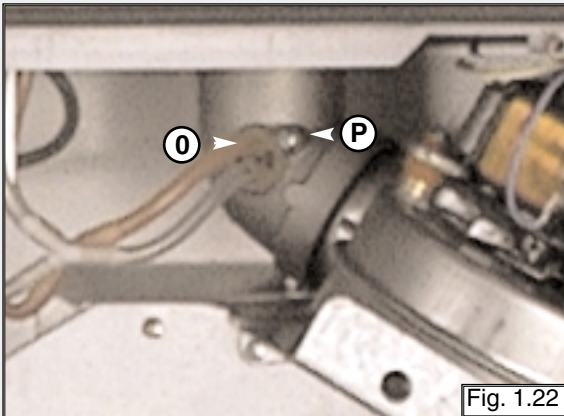

A/23 MFFI

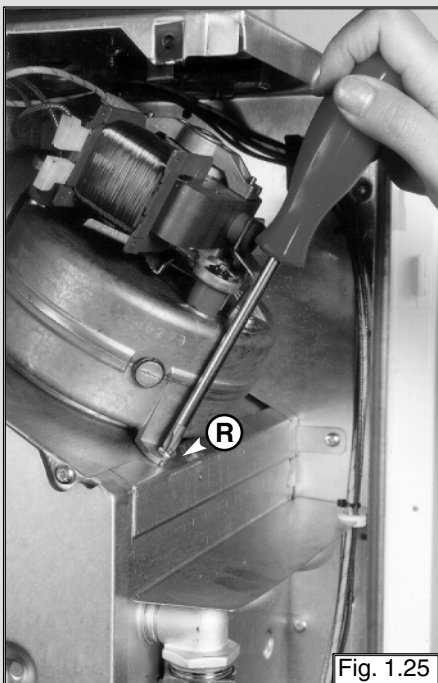
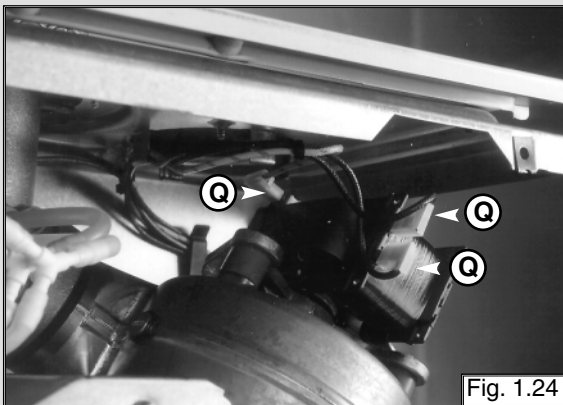

Removing the fan (A/23 MFFI)

1. Disconnect electrical connections "Q" (see fig. 1.24);
2. Remove screws "R" (see fig. 1.25).
3. Pull fan to the right, forward and remove (see fig. 1.26)

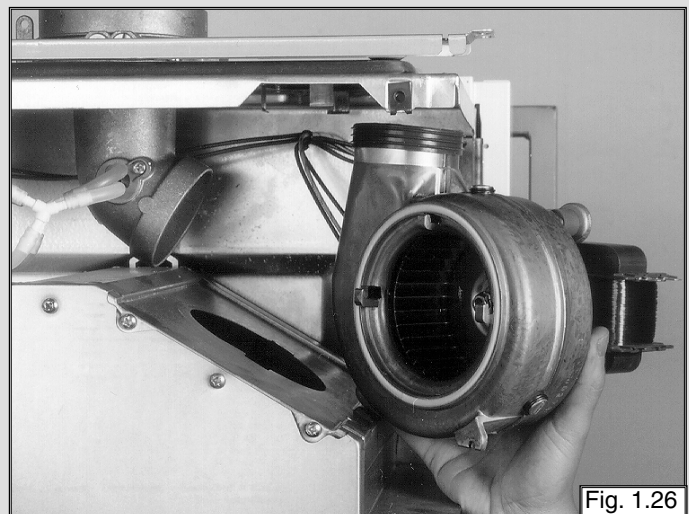

A/27 MFFI

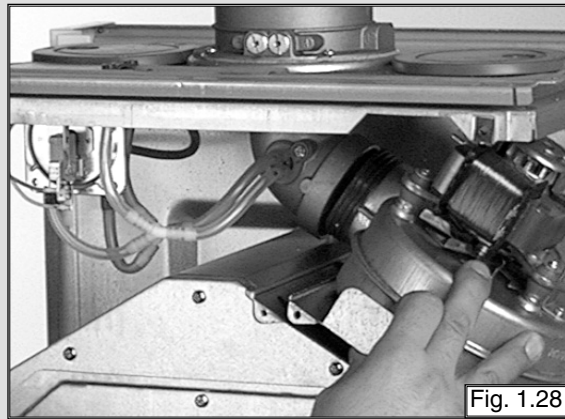
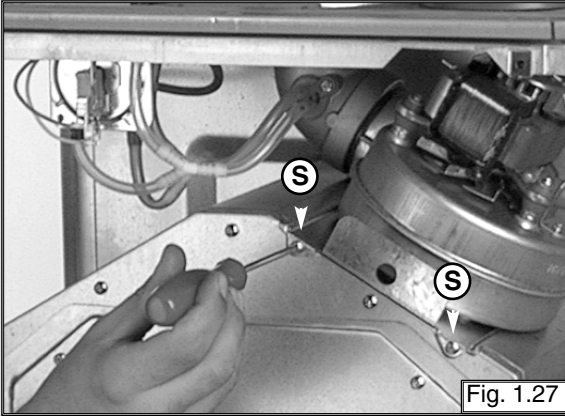

Removing the fan (A/27 MFFI)

1. Disconnect electrical connections and remove screws "S" using a No. 2 star tipped screwdriver (*see fig. 1.27*);
2. Pull fan to the right, forward and remove (*see fig. 1.28*);
3. Remove fan from mounting plate;
4. Remove screws "T" (*see fig. 1.29*).

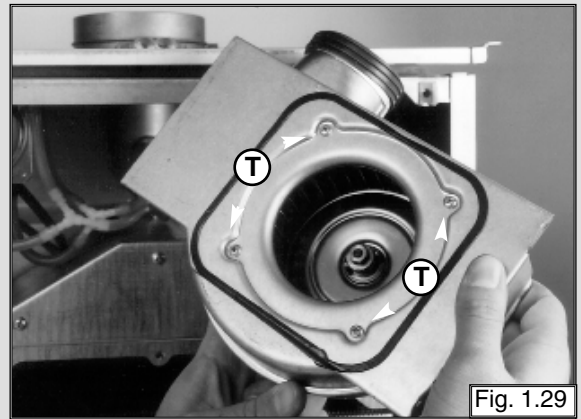

1.4 Servicing and Removal of the Gas Valve

Setting gas pressures

Setting the minimum and the maximum power of the boiler

1. Check that the supply pressure to the gas valve is a minimum of 20 mbar for natural gas.
2. To do this, remove the screw "A".
Fit the pipe of the pressure gauge to the pressure connection of the gas valve "B".
When you have completed this operation, replace the screw "A" securely into its housing to seal off the gas.
3. To check the pressure supplied by the gas valve to the burner, remove the screw "C". Fit the pipe of the pressure gauge to the pressure outlet of the gas valve "D".
Disconnect the compensation pipe either from the gas valve or from the sealed chamber.
4. Set the On/Off button to position $\textcircled{1}$ and the "summer/winter" switch to the winter position.
To set the maximum power, turn on the hot water tap and allow the hot water tap to run at a rate of about 8 litres/minute so that the main burner lights.
Adjust nut "E" on the modureg to set the gas pressure (displayed on the pressure gauge) corresponding to the maximum power (see table "A" page 11).
5. To set the minimum power, disconnect a supply terminal from the modureg and adjust screw "F".
Turn the screw clockwise to increase the pressure and counter-clockwise to decrease the pressure (displayed on the pressure gauge) corresponding to the minimum power (see table "A" page 11).
6. When you have completed the above operations, turn off the hot water tap, re-connect the supply terminal to the modureg on the gas valve and replace the cap on the screw of the modureg.

Setting the maximum heating circuit power

7. To set the maximum heating circuit power, place the On/Off button to position $\textcircled{1}$ and the "summer/winter" switch to winter position.
Turn the knob of the heating thermostat clockwise to maximum;
8. Remove the left hand inspection panel of the P.C.B. and fit a small cross-head screwdriver in to the right hand potentiometer. Turn clockwise to increase the pressure or counter-clockwise to reduce the pressure.
Adjust the setting to the required heating pressure value (displayed on the pressure gauge), as indicated in the diagrams shown in page 11.
9. Turn off the boiler by placing the main switch to the "Off" position.

Setting pressure for soft ignition.

Disconnect the detection electrode connection from the P.C.B. (see fig. 1.13).

Start the boiler and during the ignition sequence adjust the centre potentiometer until the gas pressure reads the required gas pressure as per the table below.

Once the gas pressure is set turn off the boiler and reconnect the connection to the P.C.B.

NB.: It may be necessary to reset the flame failure reset a number of times during this operation.

	NATURAL GAS (G20)	BUTANE GAS (G30)	PROPANE GAS (G31)
Recommended pressure for soft light ignition	5 mbar - 1.95 in w.g.	18 mbar - 7.0 in w.g.	19 mbar - 7.4 in w.g.

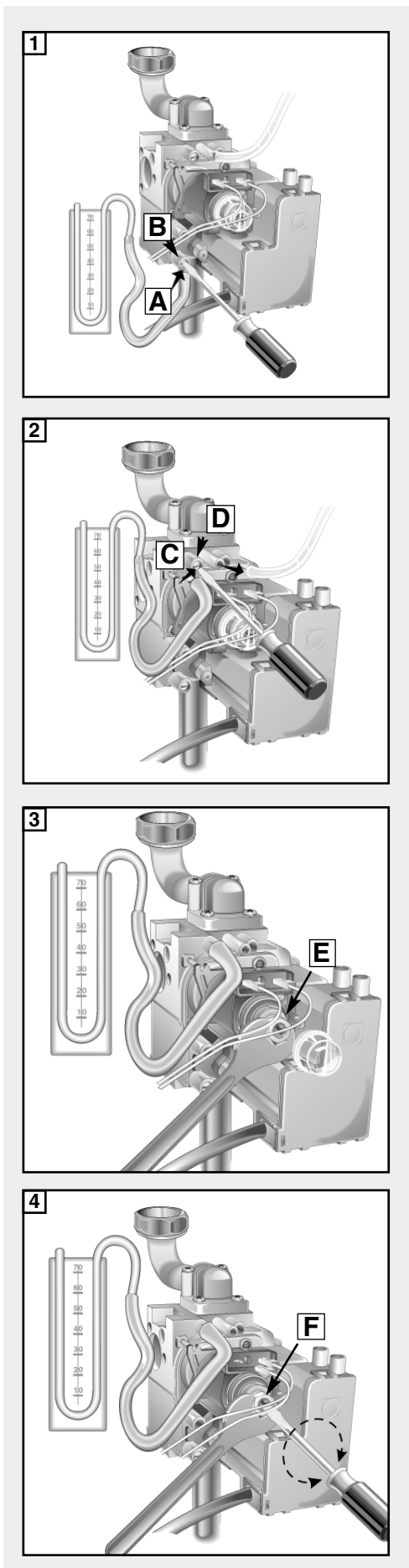

Regulating the heating power for natural gas (G20)

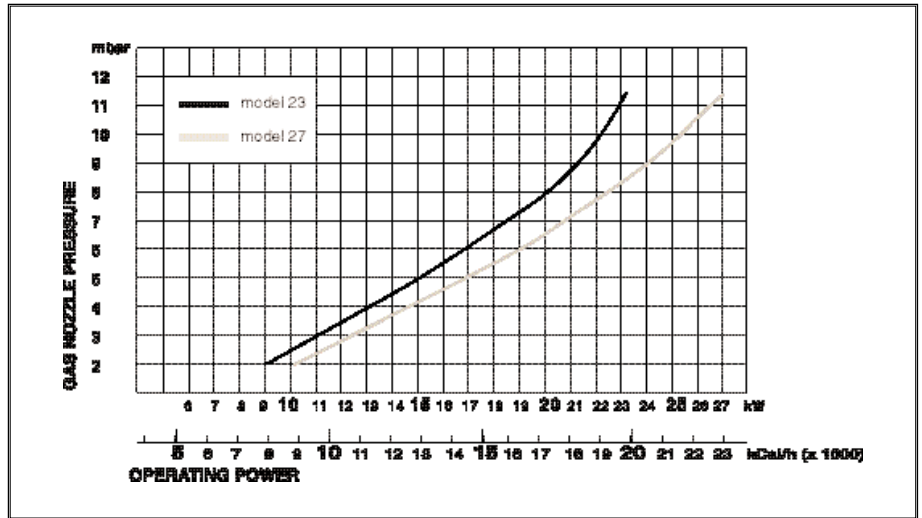

Regulating the heating power for butane gas (G30)

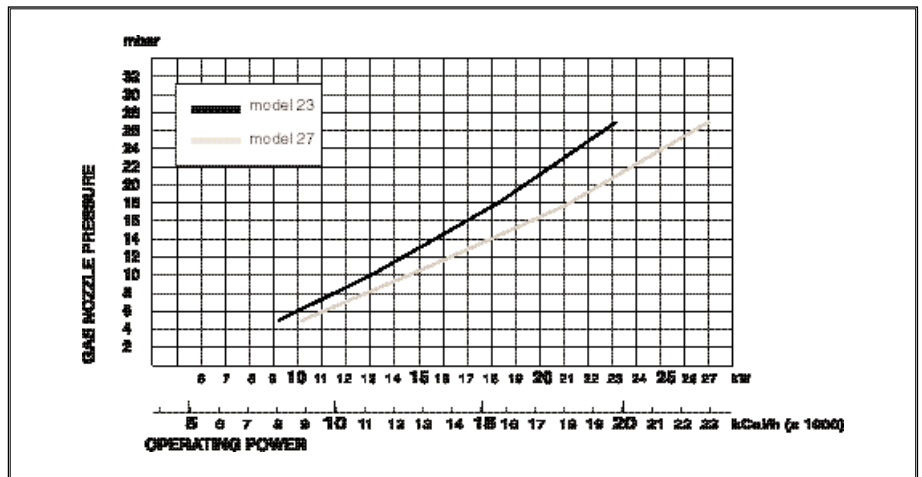

Regulating the heating power for propane gas (G31)

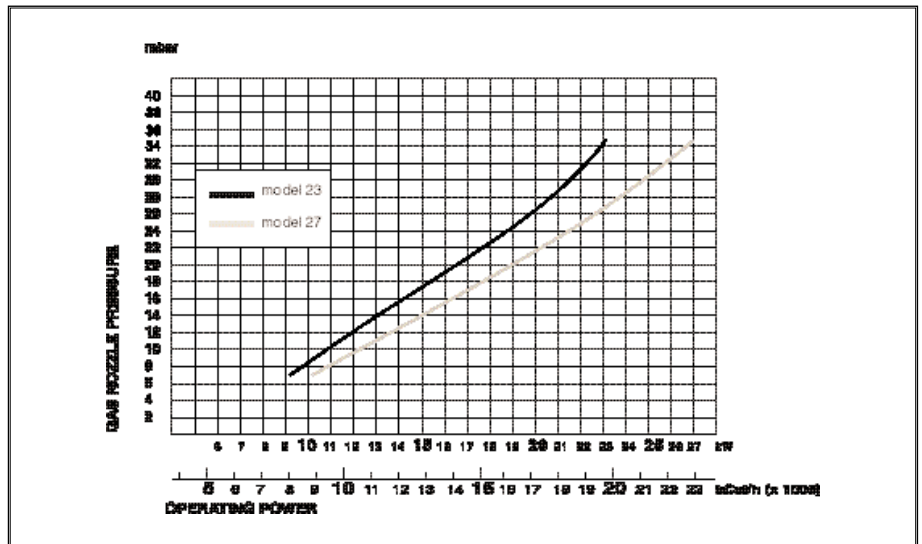
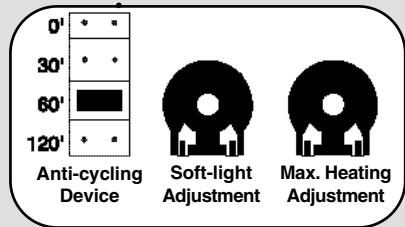
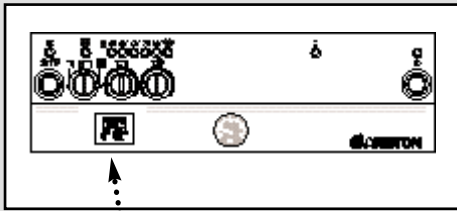

TABLE "A"

GAS REQUIREMENTS		NATURAL GAS (G20)		BUTANEGAS (G30)		PROPANEGAS (G31)	
Gas rate	max	3.0 m ³ /h	106.0 ft ³ /h	0.88 m ³ /h	31.1 ft ³ /h	1.15 m ³ /h	40.6 ft ³ /h
Gas rate	min	1.2 m ³ /h	42.3 ft ³ /h	0.35 m ³ /h	12.3 ft ³ /h	0.46 m ³ /h	16.2 ft ³ /h
Inlet pressure		20 mbar	7.8 in w.g.	28 mbar	10.9 in w.g.	37 mbar	14.4 in w.g.
Burner pressure	max	12.3 mbar	4.8 in w.g.	28 mbar	10.9 in w.g.	37 mbar	14.4 in w.g.
Burner pressure	min	2.0 mbar	0.8 in w.g.	5.1 mbar	2.0 in w.g.	7.0 mbar	2.7 in w.g.
Burner Injectors	A23 MFFI	13 x 1.25		13 x 0.72		13 x 0.72	
Burner Injectors	A27 MFFI	15 x 1.25		15 x 0.72		15 x 0.72	



10. Remove the pipe from the pressure gauge and connect screw “C” to the pressure outlet in order to seal off the gas.
11. Carefully check the pressure outlets for gas leaks (valve inlet and outlet).

IMPORTANT!

Whenever you disassemble and reassemble the gas connections, always check for leaks using a soap and water solution.

Setting the anti-cycling device

This appliance is equipped with a potentiometer which delays the ignition of the heating control and is situated on the P.C.B. (see the electrical diagrams). By adjusting the potentiometer, it is possible to change the time interval between the burner shutting down and its next ignition.

It is preset at 1 minute and can be adjusted from 0 to 2 minutes.

Use this control in particular situations where continuous shutting down and ignition of the main burner occurs.

Removing the spark generator (SIT Sigma gas valve)

1. Disconnect ignition leads “U” by pulling upwards (see fig. 1.30);
2. Remove the screws “V” (see fig. 1.31) with a Pozidrive No. 2 star tip screwdriver;
3. Remove the spark generator.

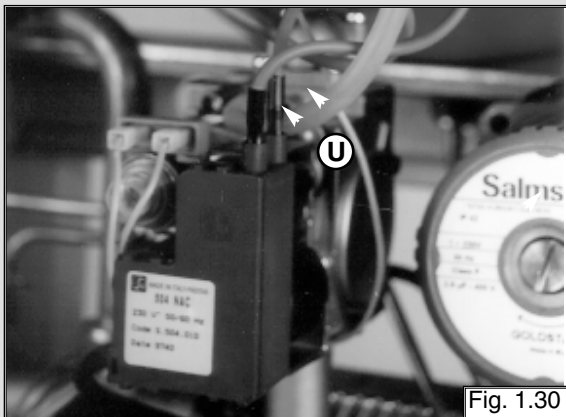

Fig. 1.30

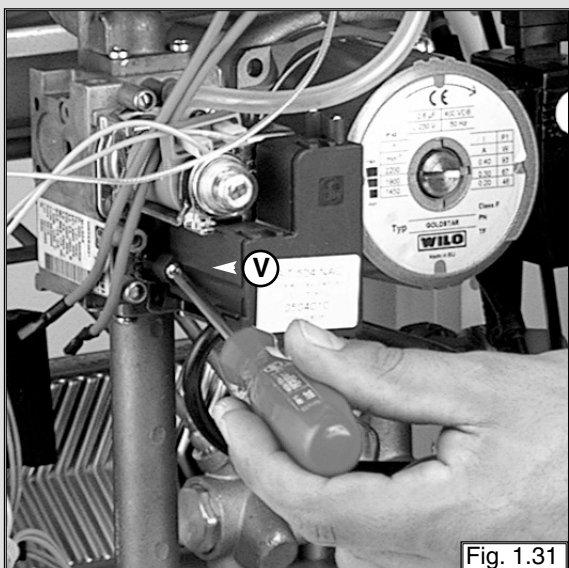

Fig. 1.31

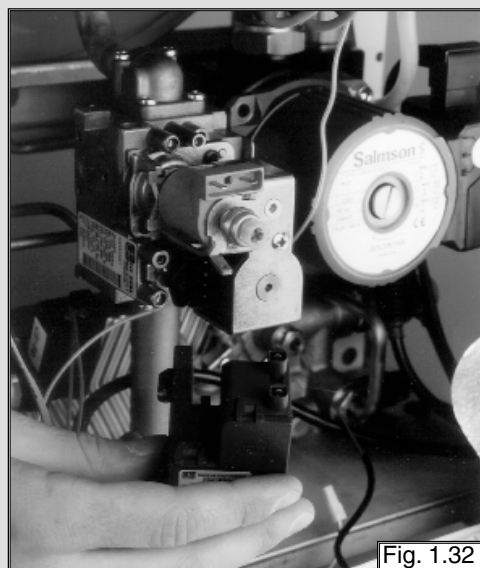
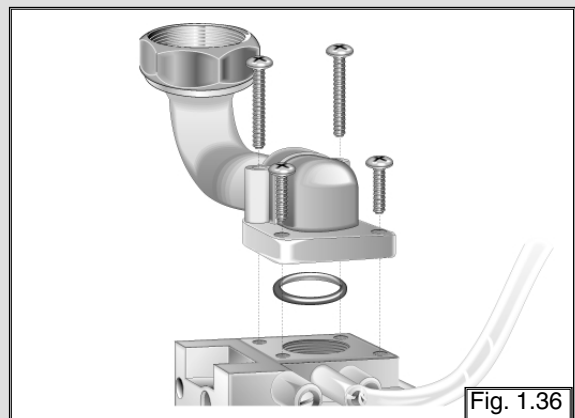
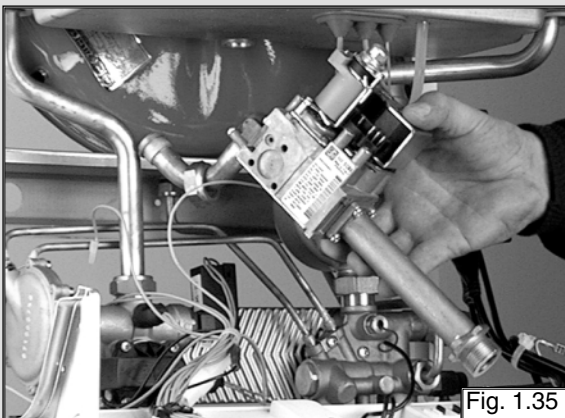
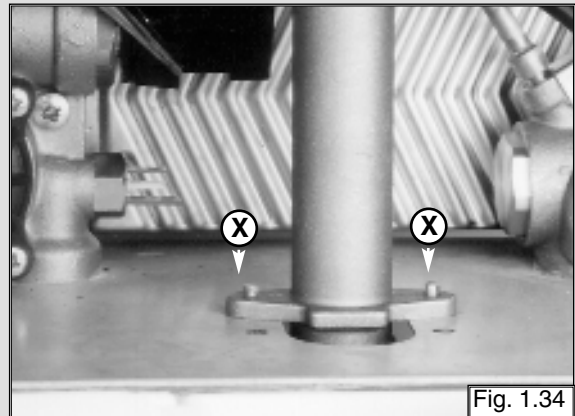
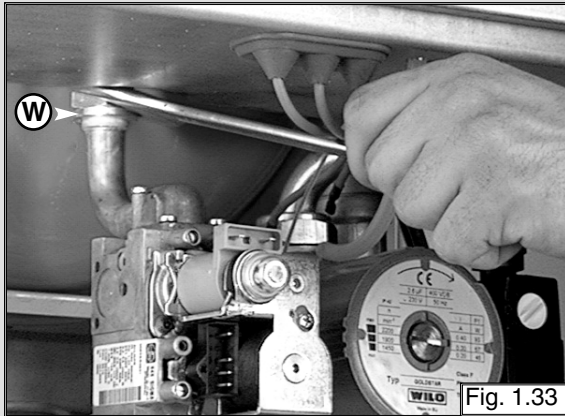

Fig. 1.32

Removing the gas valve

1. Disconnect all the cables from the solenoid and modureg;
2. Remove the spark generator;
3. Release the top nut "W" using a 30 mm open ended spanner (see fig. 1.33);
4. Remove the screws "X" from the bottom of the gas valve pipe (see fig. 1.34).

Attention!! The gas valve is connected with the two pipes (as shown) with an O-ring connection.



1.5 Access to the Hydraulic Circuits

Important! Before any component is removed, the boiler must be drained of all water.

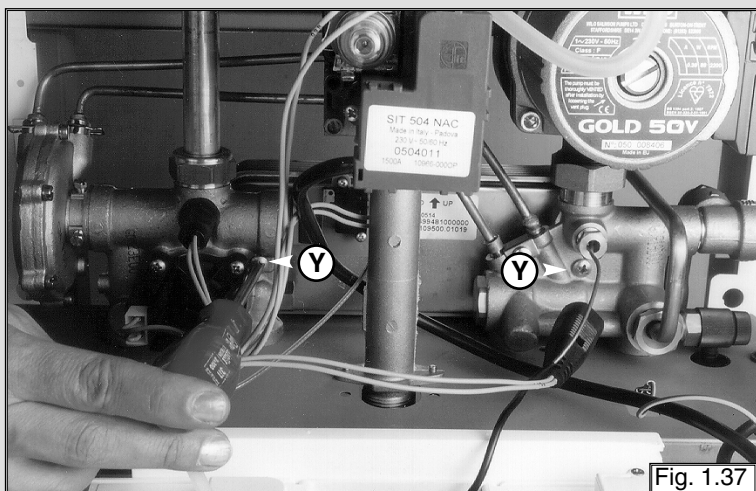

Removing the D.H.W. (secondary) exchanger

1. Remove the screw "Y" (see fig. 1.37);
2. Push the exchanger towards the rear of the boiler, lift upwards and remove out of the front of the boiler;
3. Before replacing the exchanger ensure that the O-rings are in good condition and replace if necessary.

Removing the safety valve

1. Loosen nut "Z" (see fig. 1.38);
2. Unscrew and remove the valve (see fig. 139)

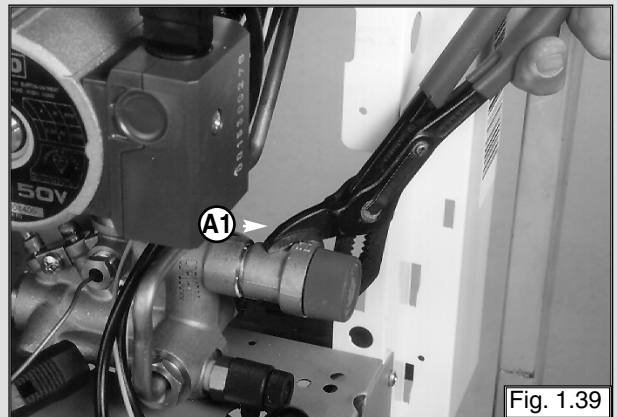
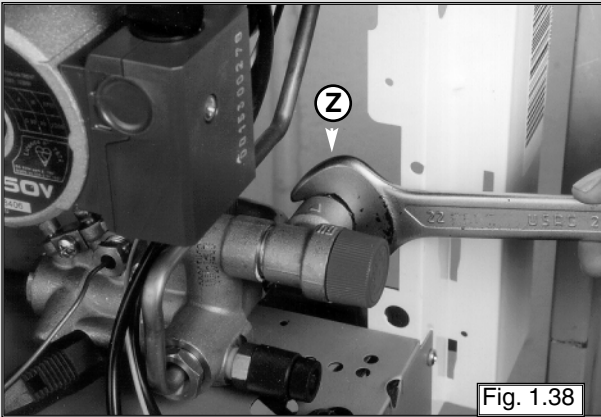

Removing the automatic air vent

1. Unscrew valve "A1" (see fig. 1.39).

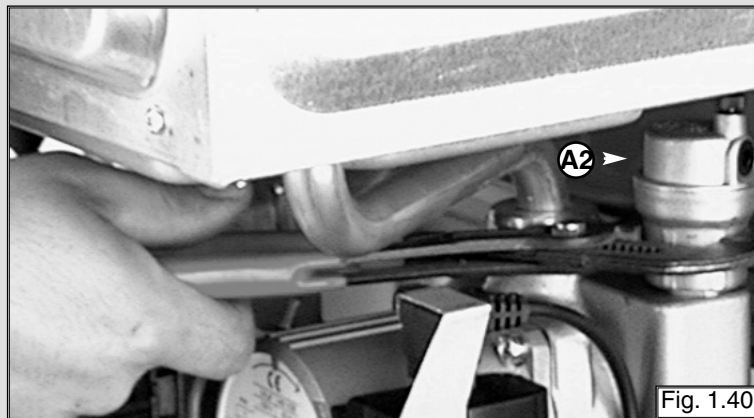

Removing the main circuit flow switch

1. Remove the cable of the main circuit flow switch "A3" (see fig. 1.41);
2. Remove the screws "A4" (see fig. 1.42);
3. Remove the main circuit flow switch.

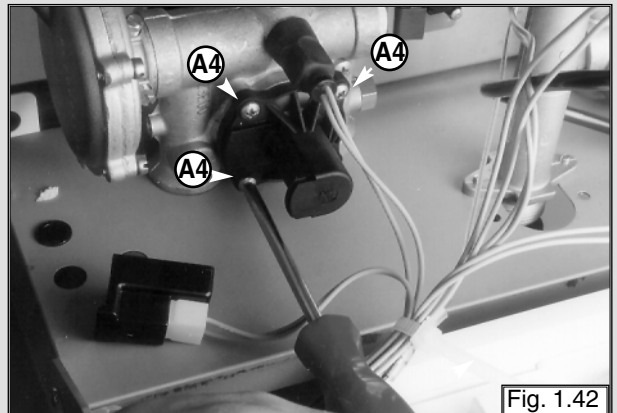
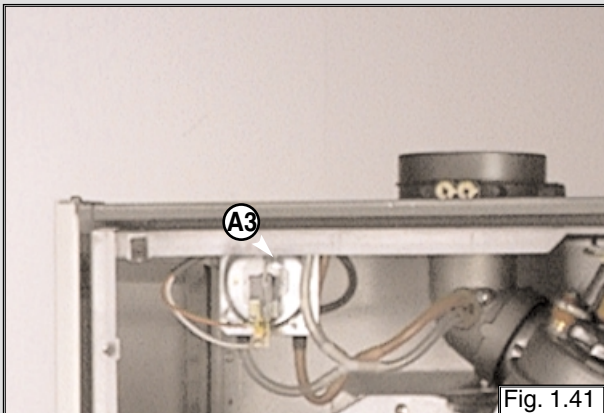

Removing the pump

1. Remove the electrical connection "A5"
(see fig. 1.43);
2. Release the nuts "A6" and remove the pump
(see fig. 1.44).

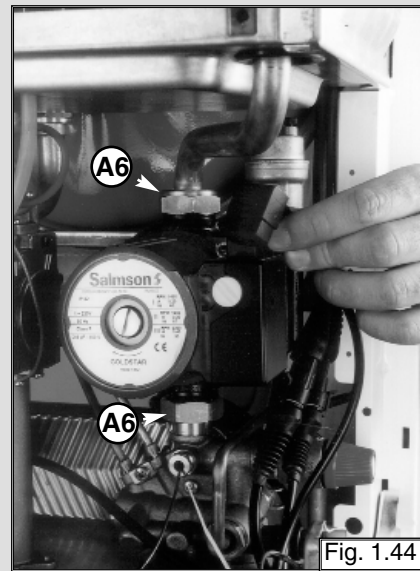
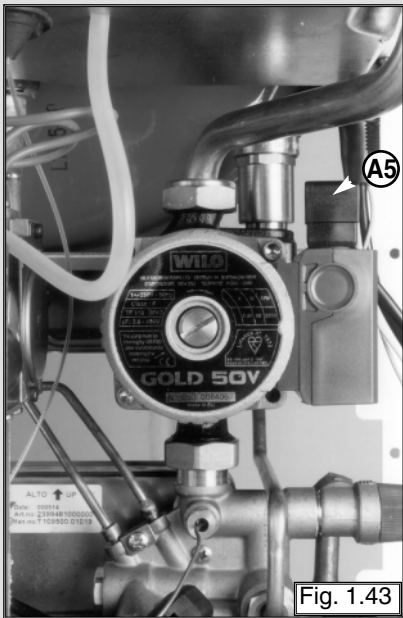

Removing the pressure gauge

1. Remove the inspection panel
(see fig. 1.6 - 1.7);
2. Release coupling "A7" using a 14 mm open ended
spanner (see fig. 1.45);
3. Push the pressure gauge through the control panel
from the rear (see fig. 1.46).

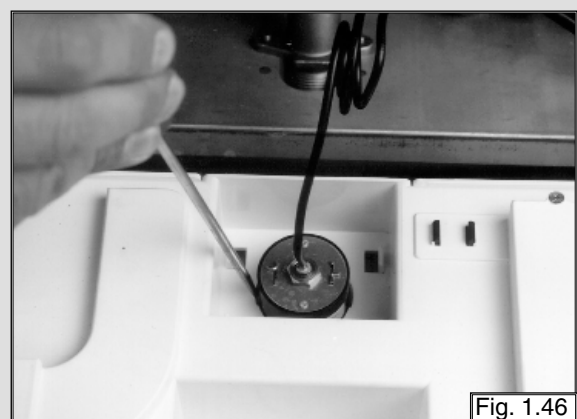
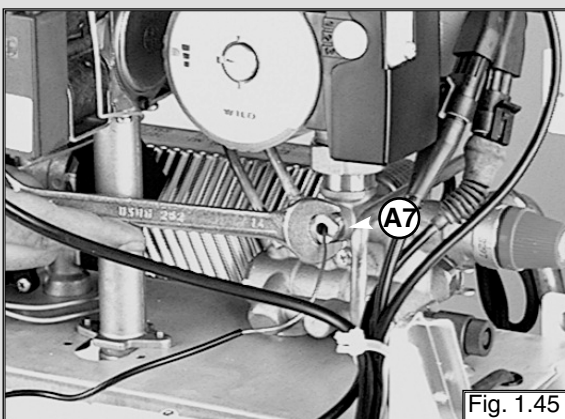

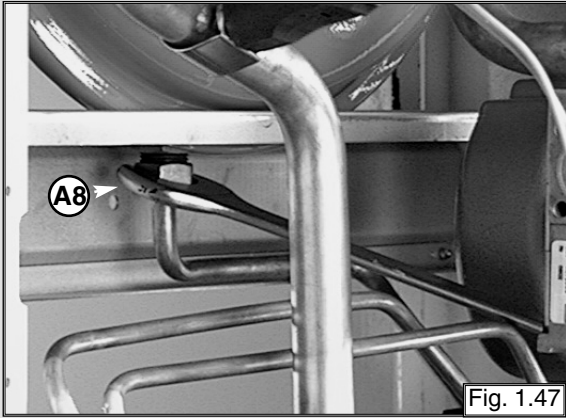

Fig. 1.47

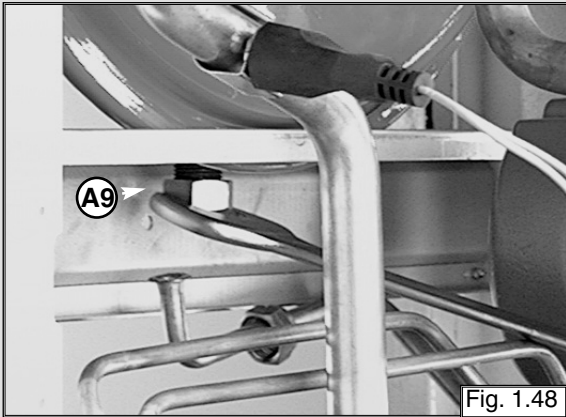

Fig. 1.48

Removing the expansion vessel

1. Remove nut "A8" away from the expansion vessel (see fig. 1.47);
2. Remove nut "A9" (see fig. 1.48);
3. Remove expansion vessel (see fig. 1.49).

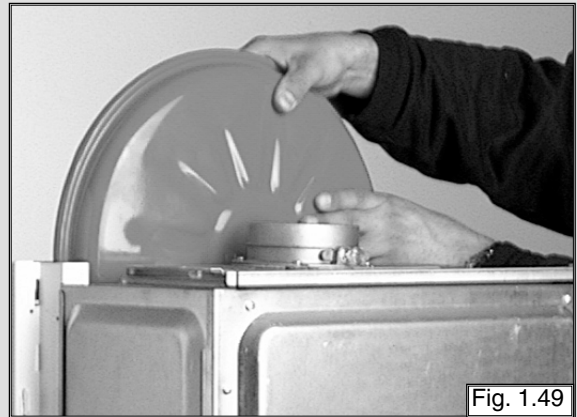

Fig. 1.49

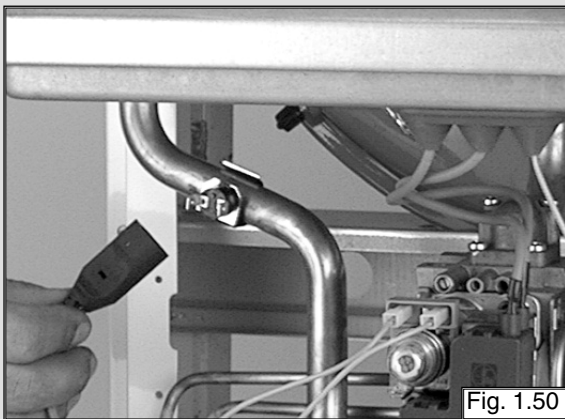

Fig. 1.50

Removing the overheating thermostat

1. Remove the electrical connection from the overheating thermostat (see fig. 1.50);
2. Then remove the thermostat from the pipe by releasing its securing clip.

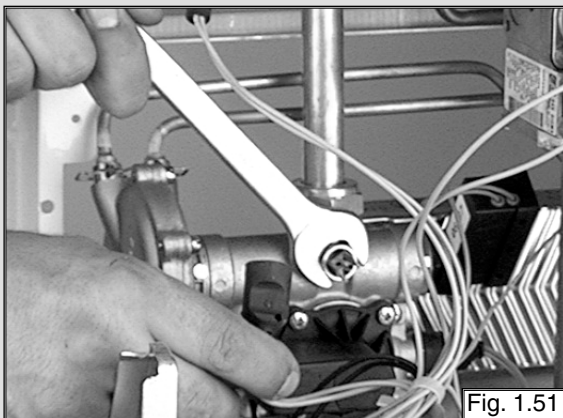

Fig. 1.51

Removing the heating temperature sensor (N.T.C.)

1. Remove the electrical connector by pulling off the thermostat connections and unscrewing the sensor probe with a 14 mm open ended spanner (see fig. 1.51).

1.6 Access to the Control System

Checking fuse

1. Remove the inspection panel (see fig. 1.6 - 1.7);
2. Remove fuse (see fig. 1.52).



Removing the time clock

1. Remove the inspection panel (see fig. 1.6 - 1.7);
2. Remove electrical connection of the clock "B1" (see fig. 1.53);
3. Unclip the clock from the panel and remove (see fig. 1.54).

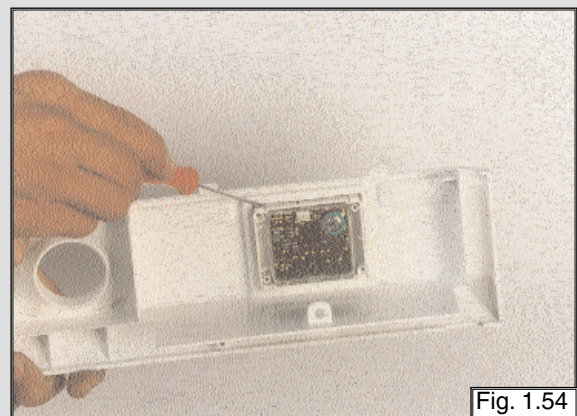
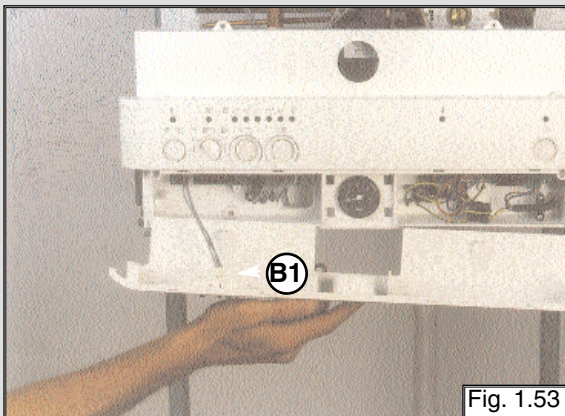

N.B.

It is possible to by-pass the time clock in the event of failure by simply unplugging the electrical connection from the P.C.B. (see fig. 1.48). This will revert control of the central heating to the room stat connection on the reverse of the control panel.

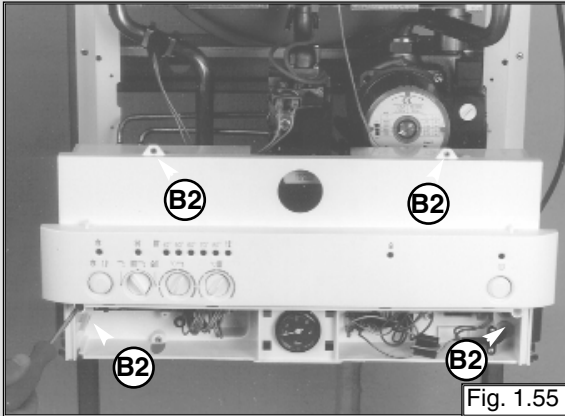

Fig. 1.55

Removing the P.C.B.s

1. Isolate electricity;
2. Remove the front cover of the boiler;
3. Remove the inspection panel (see fig. 1.6-1.7);
5. Remove the mounting screws "B2" (see fig. 1.55);
6. Disconnect the connection cable "B3" (see fig. 1.56);
7. To remove the 24V P.C.B.: remove the electrical plug connectors and screws "B4" (see fig. 1.57);
8. To remove the 240V P.C.B.: remove the electrical plug connectors and screws "B5" (see fig. 1.58);
9. Replace either P.C.B. in reverse order.

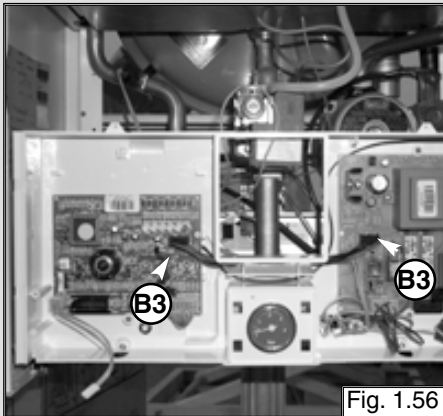

Fig. 1.56

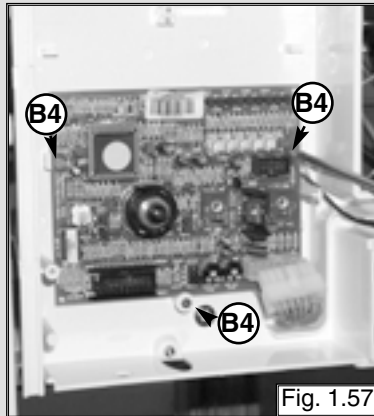

Fig. 1.57

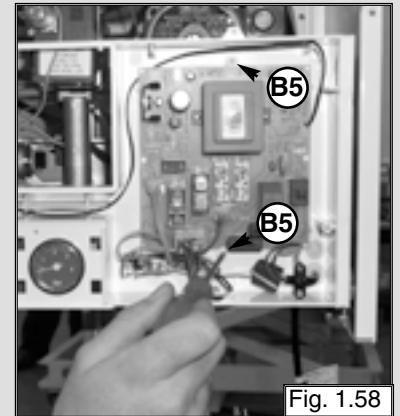
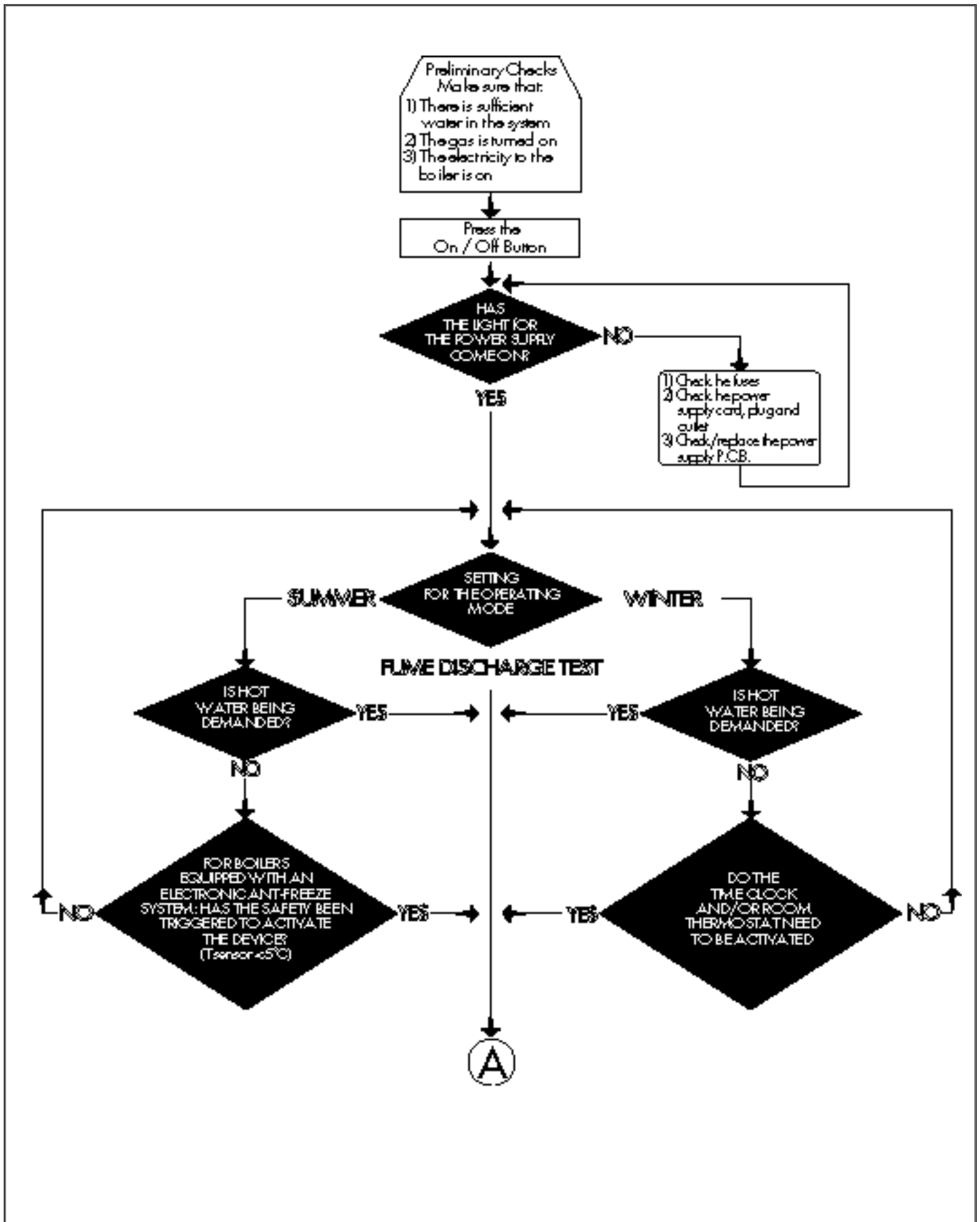

Fig. 1.58

2. FAULT FINDING

2.1 Fault Finding Guide (Flow-chart)

It is possible to detect and correct any defect by using the standard fault finding diagrams described in this chapter.



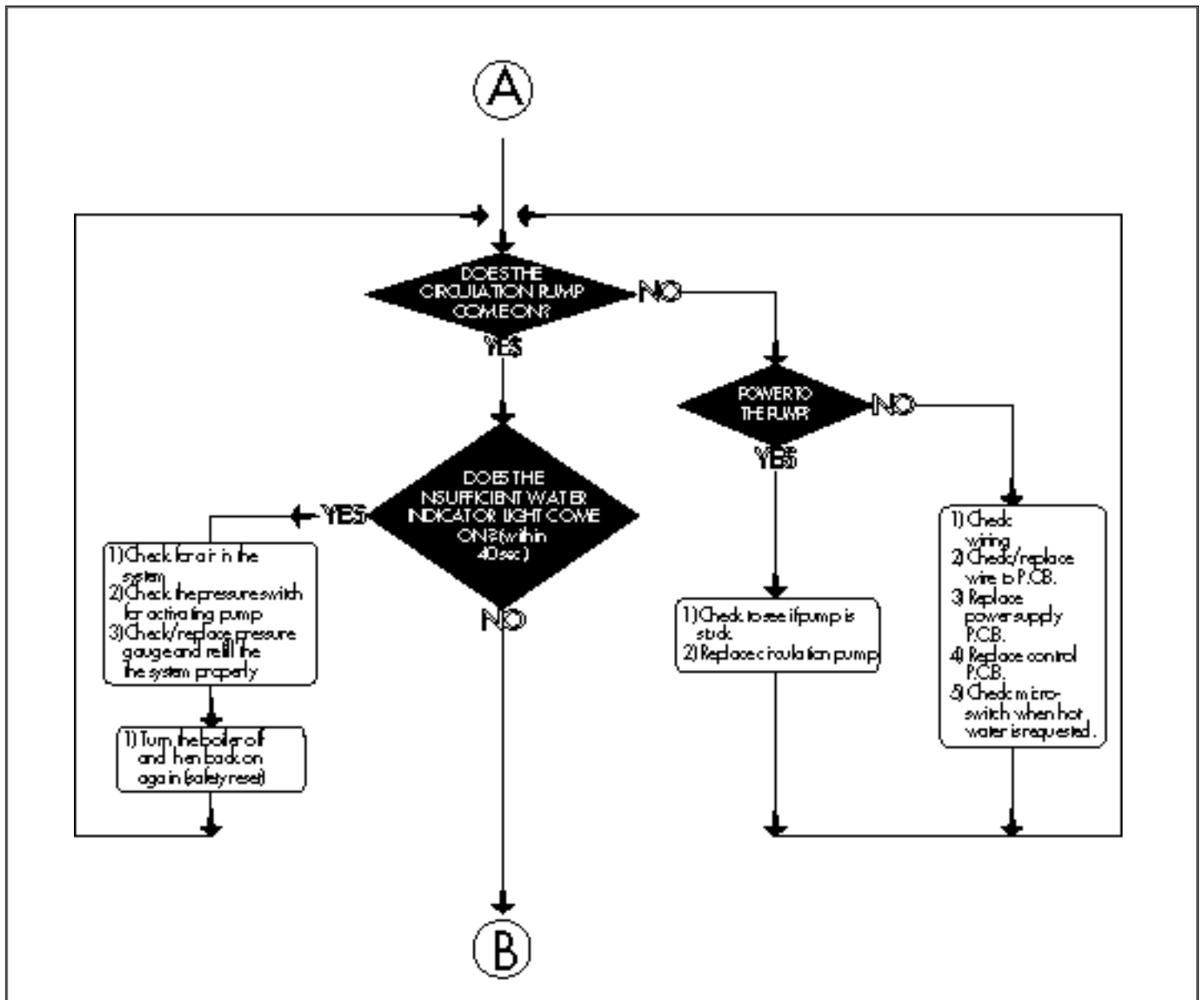

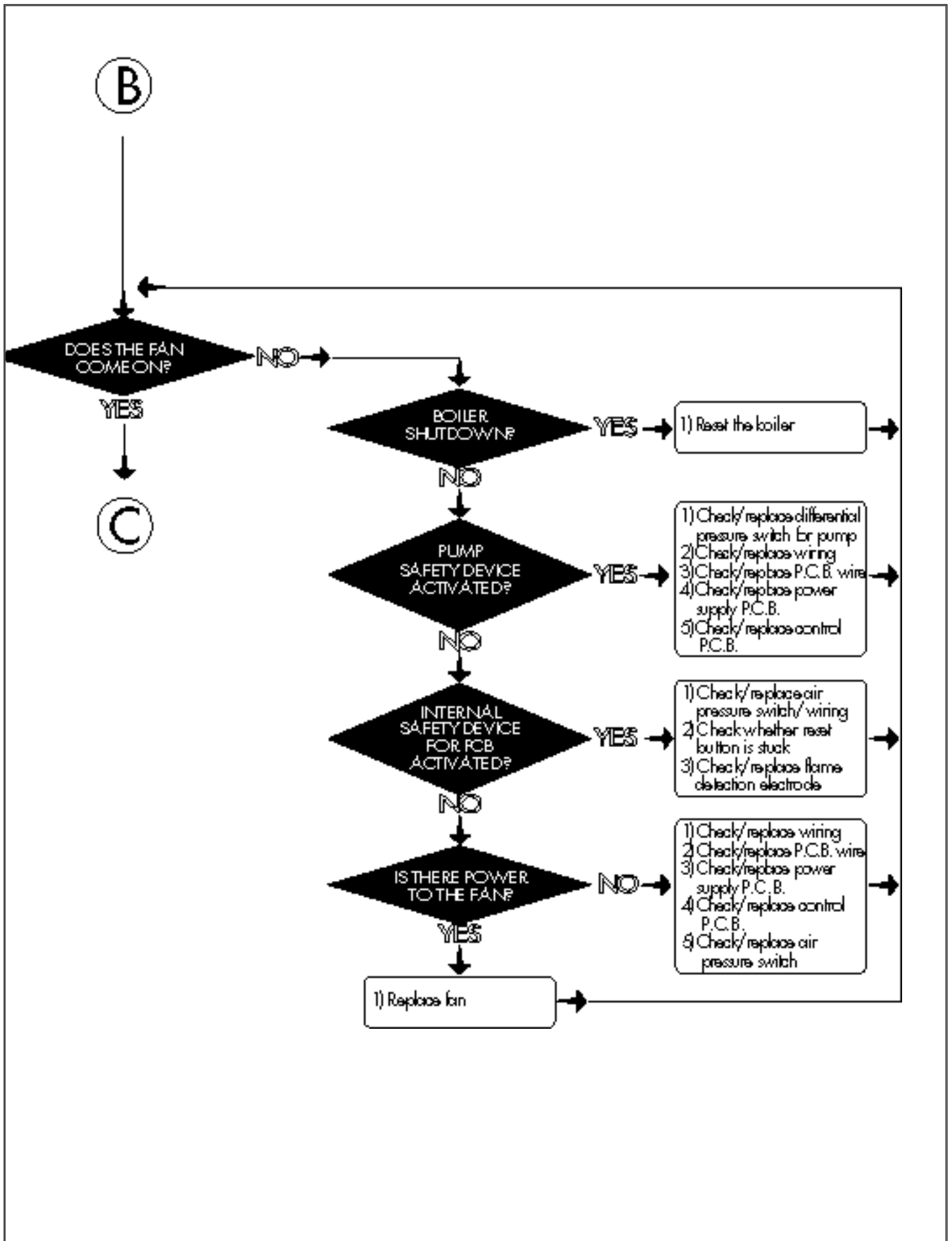

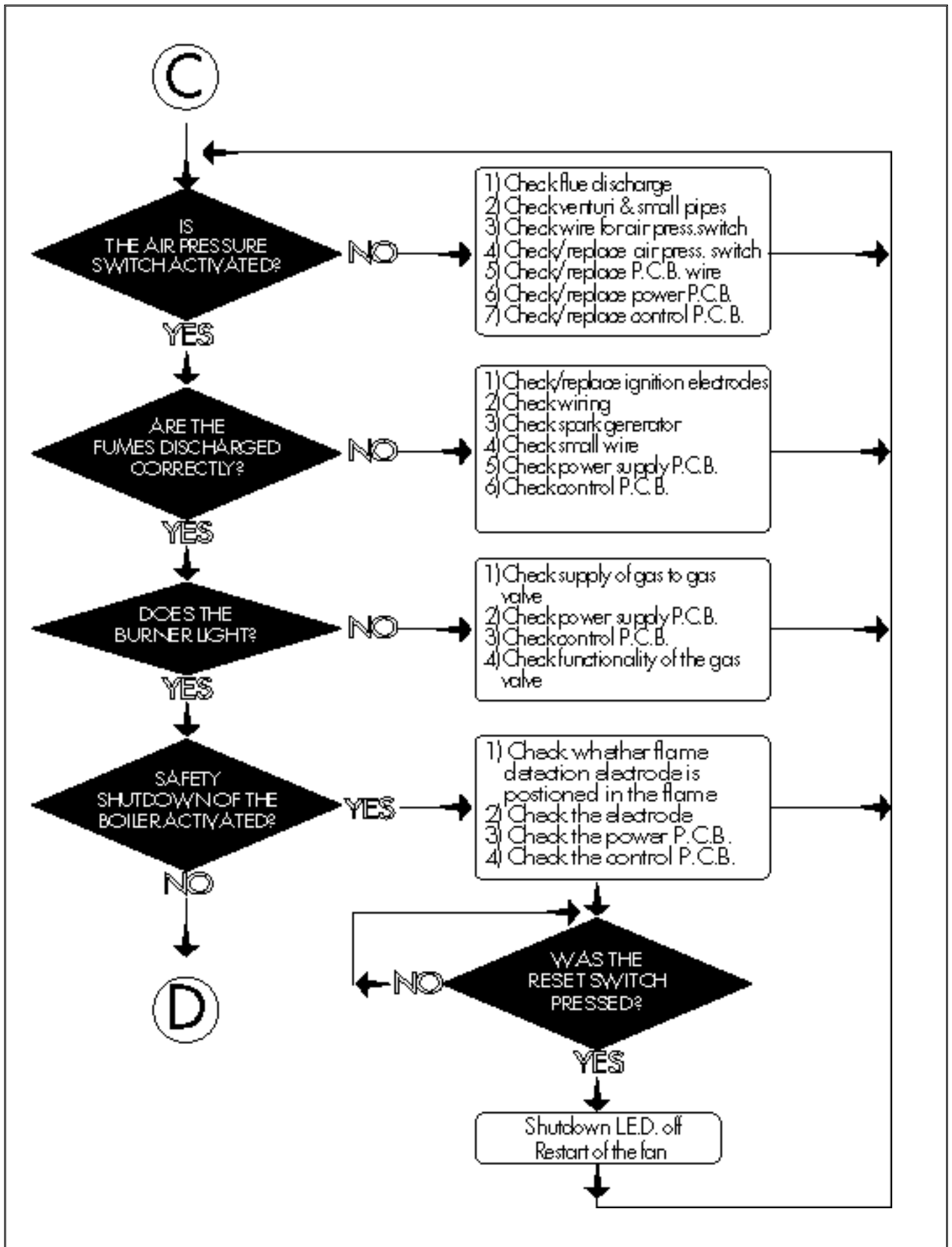

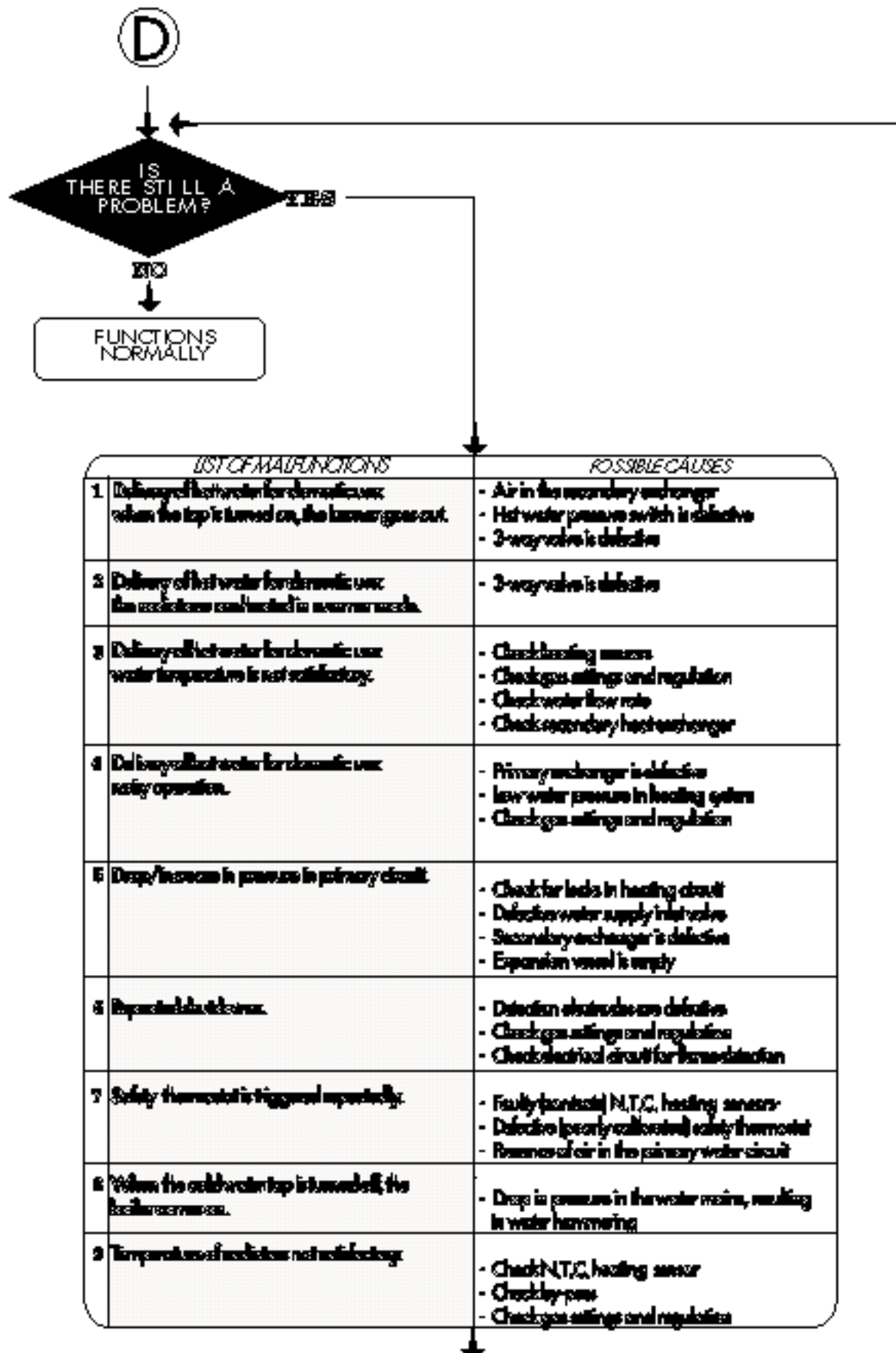

3. ELECTRICAL DIAGRAMS

Legend:

AT = High Voltage P.C.B.
BT = Low Voltage P.C.B.
B = Flame Failure L.E.D.
C = Insufficient Water Pressure L.E.D.
D = Water Temperature Indicator L.E.D.s
E = Overheat Thermostat Warning L.E.D.
F = System Reset Button
G = Selector Knob for Operating Mode
H = Domestic Hot Water Temp. Adjustment
I = Central Heating Temp. Adjustment
J = Wire Connector for Room Thermostat
K = Antifreeze feature selector.
L = Connector for Total Check System
M = Anti-cycling Device Adjustment for Heating
N = Soft-light Adjustment
O = Max Heating Temperature Adjustment
Q = On/Off L.E.D.
R = On/Off Switch
S = Interface Wire for P.C.B.s
T = Relay Motorised Valve
U = Ignitor Relay
V = Gas Valve Relay
W = Fan Relay
X = Circulation Pump Relay
Y = Selector TCS

A01 = Air Pressure Switch
A02 = Fan
A03 = Gas Valve
A04 = Ignitor
A05 = Motorised Valve
A06 = Circulation Pump
A07 = Flame Detector
A08 = Earth Terminal
A09 = Flame Detection Circuit
A10 = Flame Indicator L.E.D.
A11 = Transformer
A12 = Filter

B01 = Over Heat Thermostat
B02 = Room Thermostat
B03 = Gas Valve Modulator
B05 = Heating Sensor
B06 = Pressure Switch for Heating Circuit
B07 = Microswitch for Diverter Valve
B08 = Time Clock

Colours

Gry = Grey
Rd = Red
Bl = Blue
Grn/Yll = Yellow/Green
Wh = White
Brn = Brown
Blk = Black
Wh/Rd = White/Red

A/23 MFFI - A/27 MFFI

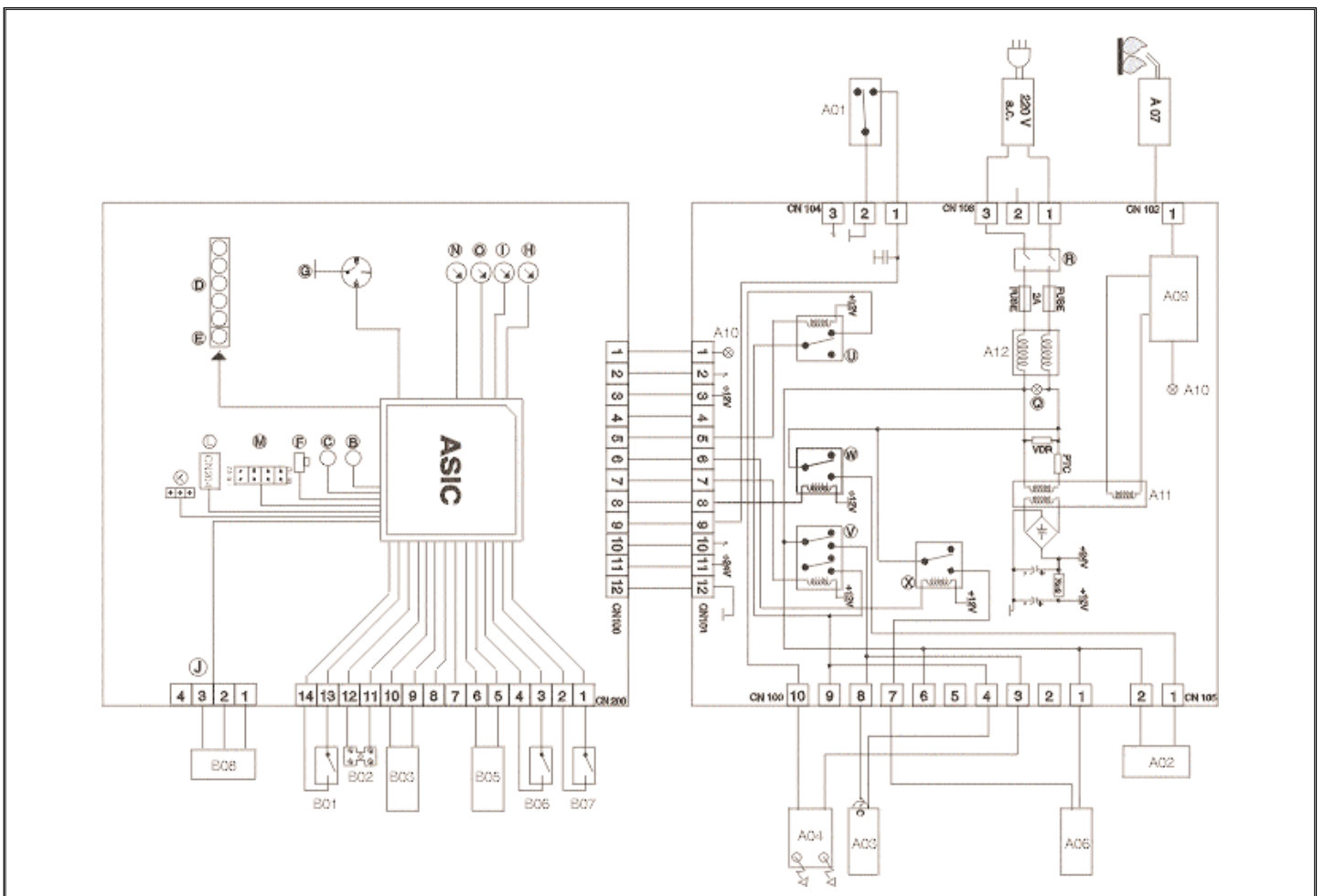
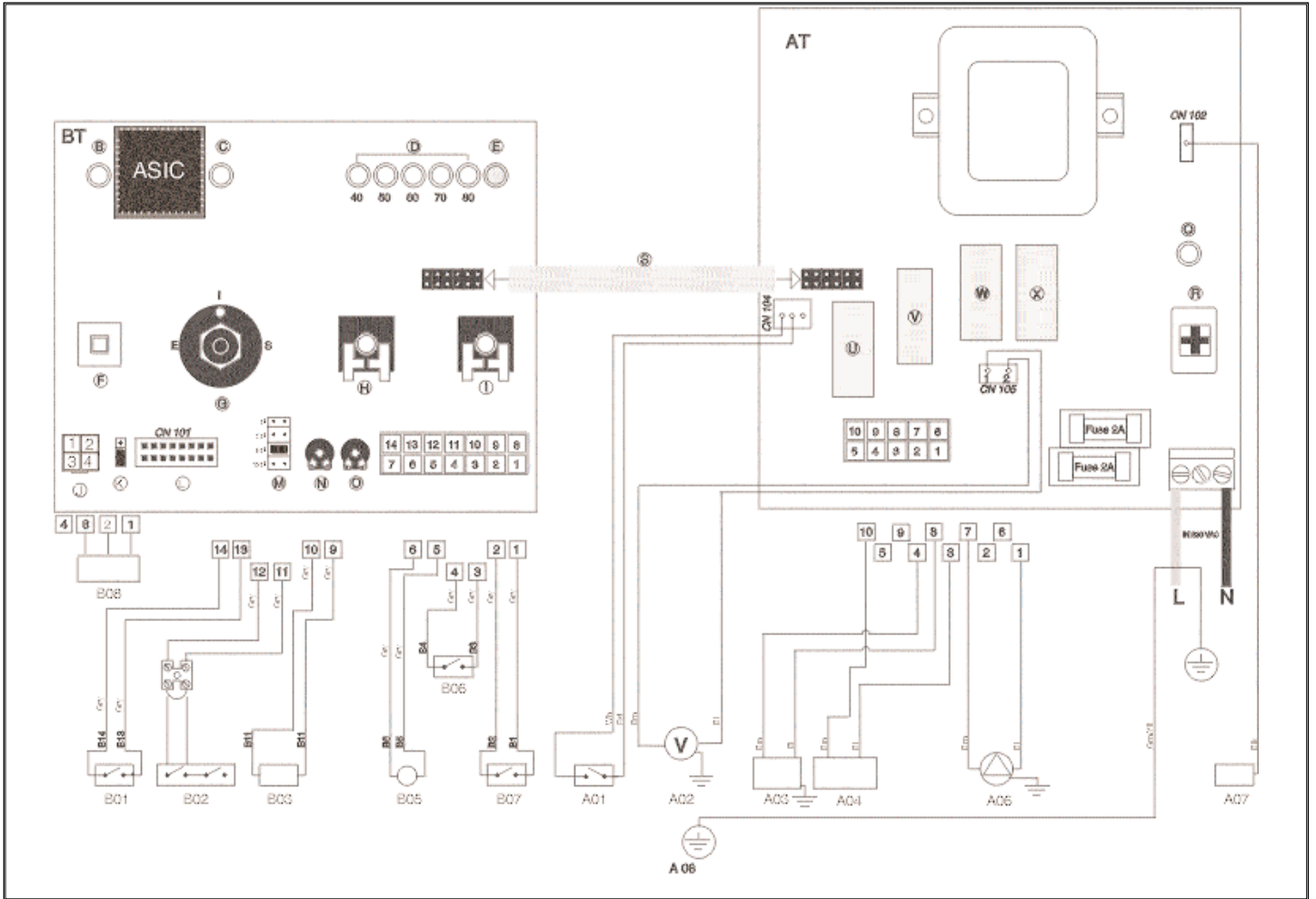

4. SHORT SPARE PARTS LIST

A/23 MFFI

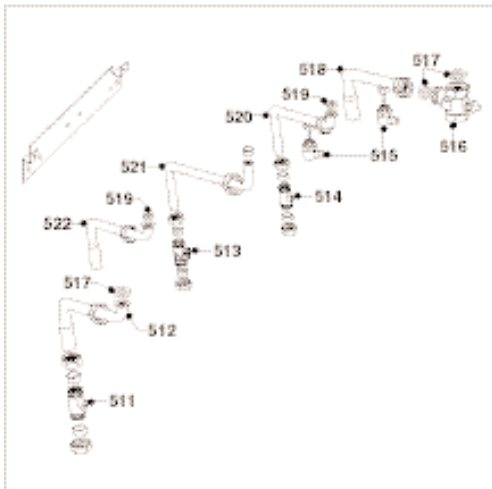
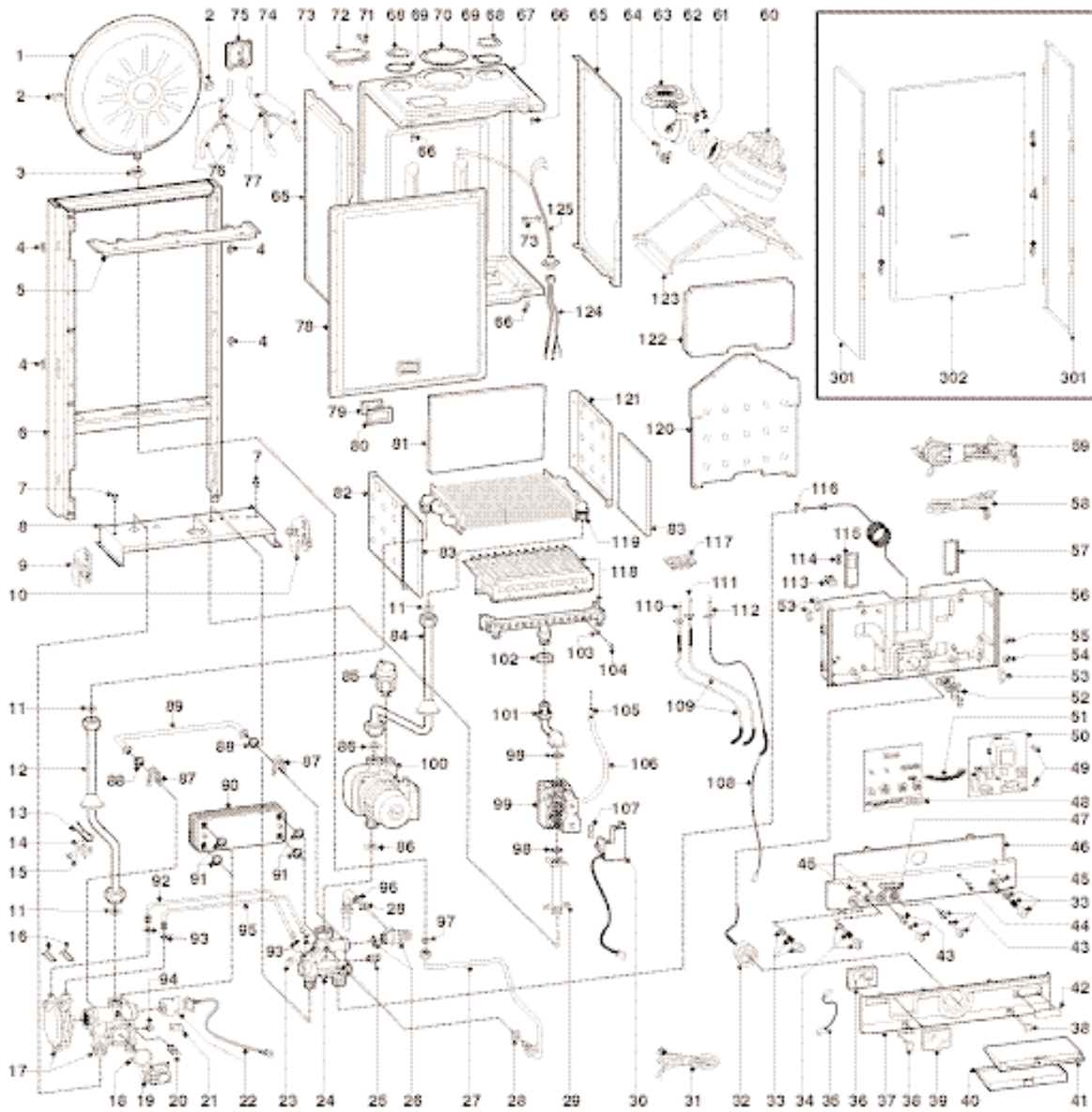

MODELS	CHARACTERISTICS	SERIAL NO: VALIDITY	REF.
A 23 MFFI UK	METHANE	2320015700001	A
A 23 MFFI UK	LPG	2320015700001	B

A/27 MFFI

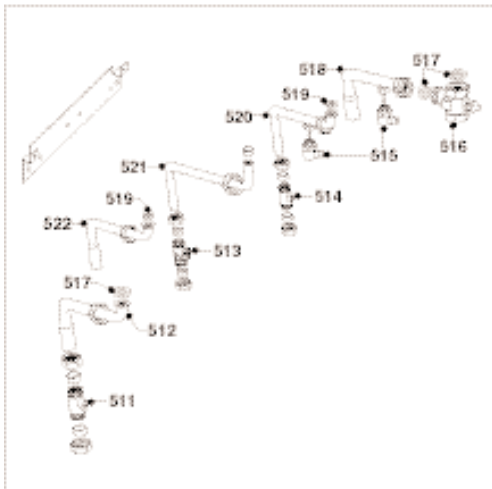
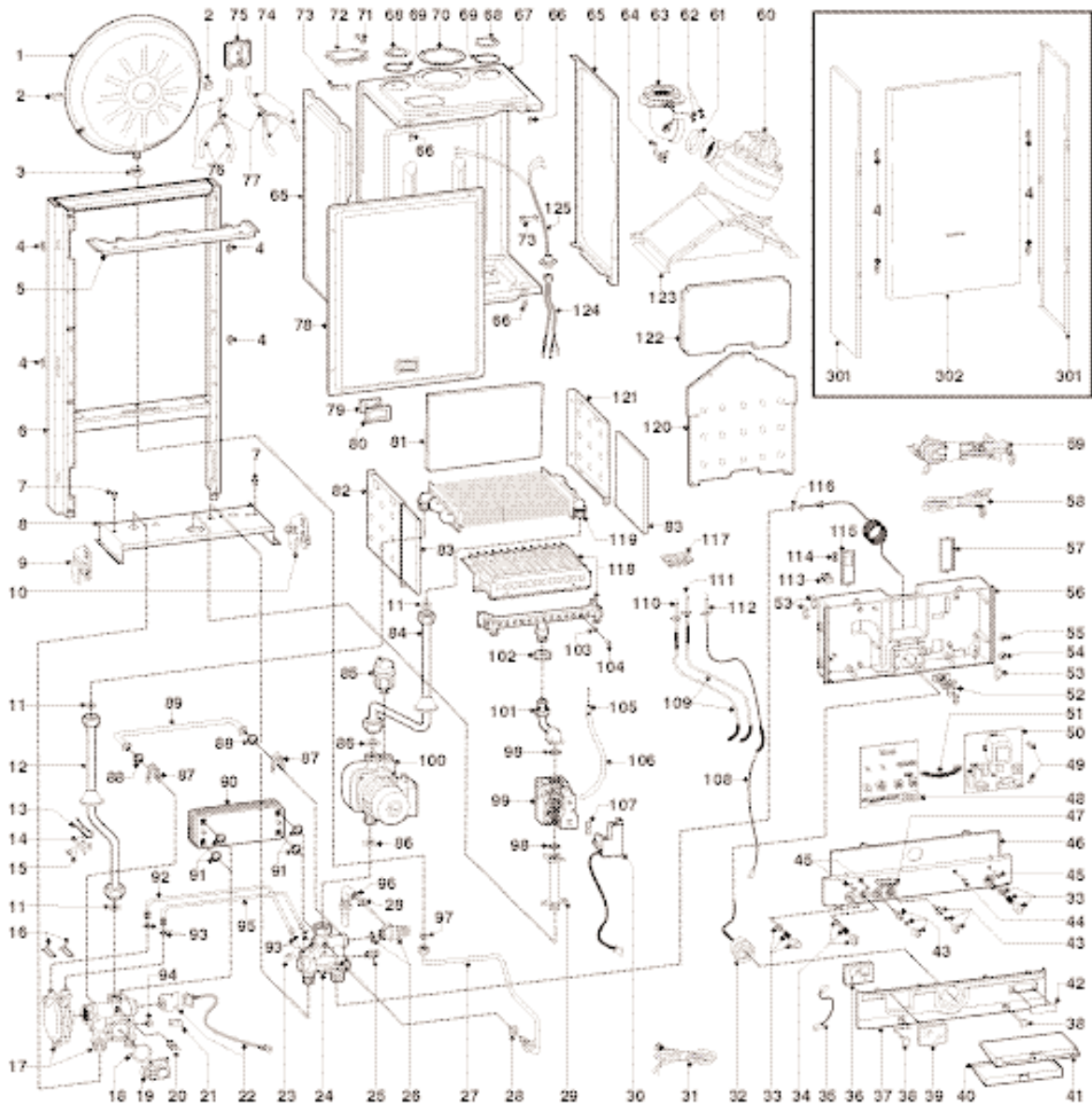

MODELS	CHARACTERISTICS	SERIAL NO: VALIDITY	REF.
A 23 MFFI UK	METHANE	2320015700001	A
A 23 MFFI UK	LPG	2320015700001	B

Manufacturer: **Merloni TermoSanitari SpA - Italy**

Commercial subsidiary: **MTS (GB) LIMITED**

MTS Building

Hughenden Avenue

High Wycombe

Bucks HP13 5FT

Telephone: (01494) 755600

Fax: (01494) 459775

internet: <http://www.mtsgb.ltd.uk>

E-mail: info@mtsgb.ltd.uk

Technical Service Hot Line: (01494) 539579