

GAS FIRED AIR HEATERS TYPE STE SERIES 2

Centrifugal Blown, Forced Convection Appliances with
Automatic Ignition and Fanned Flues for use as:
Type B22 - C12 - C32 Appliances

INSTALLATION, COMMISSIONING, SERVICING & USER INSTRUCTIONS

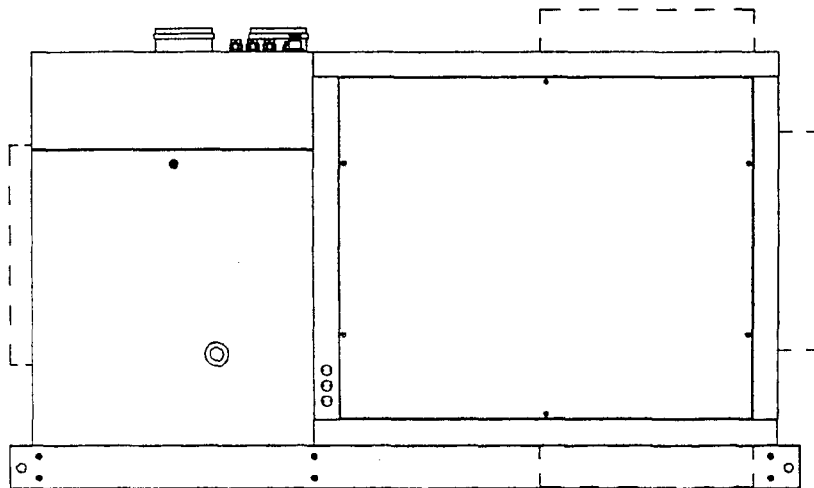

These appliances meet the following EC Directives:

Dir. CE 90/396/EEC:	GAD
Dir. CE 89/336/EEC:	EMC
Dir. CE 89/392/EEC:	MD
Dir. CE 73/23 /EEC:	LVD

PLEASE READ THIS DOCUMENT CAREFULLY BEFORE COMMENCING THE INSTALLATION AND LEAVE IT WITH THE USER OR ATTACHED TO THE APPLIANCE OR GAS SERVICE AFTER INSTALLATION

INDEX

	Page
1. General	2
2. Technical data	3
3. Installing	5
4. Combustion, air supply and flue system	8
5. Gas connection	10
6. Electrical connection	10
7. Commissioning, lighting and operation	11
8. Maintenance	13
9. Fault finding	18
10. Spare parts listing	19
11. Gas conversion	20
12. Health & Safety Statement	21
13. User instructions	22

NB. If optional equipment was ordered and supplied with this heater, please refer to additional instructions for option(s)

SECTION 1. GENERAL

- 1.1 Before installation, check that the appliance as described on the packaging label is in accordance with the correct type and model as specified on the data plate and complies with your customer order.
- 1.2 After unpacking the appliance, leave it fastened to the wooden pallet until it has been suspended or until just before base mounting. This affords protection to the underside which is normally exposed to view after installation.
- 1.3 Please read this document before commencing installation.
- 1.4 These instructions are only valid for the country of use as indicated on the appliance i.e. GB - IE. If these symbols are not shown, it is necessary to obtain appropriate technical instructions which will provide information concerning the necessary modification of the appliance for the conditions of use in the country concerned. Such instructions may be obtained upon request from your supplier.
- 1.5 Check that the local distributions conditions of electricity supply, type of gas and pressure of the appliance are compatible.
- 1.6 When installed in Great Britain the total installation must comply with the requirements and recommendations of British Standard BS 6230 1991. "Installation of Gas Fired Forced Convection Air Heaters for Commercial and Industrial Space Heating".

The installation must also be in accordance with the relevant requirements of "The Gas Safety (Installation and use Regulations and Amendment regulations 1990)" and The "Building" and "Electrical Regulations" (in GB the IEE Regulations). The requirements of the "Local Building Standards office", the premises "Insurance" undertaking and the "Fire Office" must also be observed.

Warranty

Warranty is void if (a) The installation is not in accordance with these instructions - (b) The heater is fitted in atmospheres containing flammable vapours or chlorinated or halogenated hydrocarbons - (c) The heater is fitted in the painting industry where fine starch or sugar dusts are used.

- 1.7 Unauthorised modification of this appliance or departure from use in the manner for which it was intended by the manufacturer or installed in a manner contrary to these instructions, may constitute a hazard and jeopardize all warranties. Deviations should only be carried out after formal consent has been obtained from the manufacturer.
- 1.8 Ensure the environment in which the air heater will be installed will not create a hazard i.e. where excessive (volatile) dust, flammable or corrosive substances and/or vapours and combustible materials may be present.
- 1.9 This appliance has been tested and set according to the data plate before leaving the factory.

SECTION 2. TECHNICAL DATA

Table 1 : Appliance Data

STE Series 2		II _{2H3+}	100-2	125-2	150-2	175-2	225-2	300-2	400-2
Heat input GCV (H _g)		kW	28,8	35,2	42,7	49,9	63,2	86,5	115,4
Heat input NCV (H _i)		kW	26,0	31,7	38,5	45,0	57,0	78,0	104,0
Heat output normal rate 100 %		kW	22,8	27,8	33,7	39,4	49,9	68,3	91,0
Heat output low fire rate 50 %		kW	10,8	13,2	16,0	18,6	23,6	32,2	42,9
Number of jets			4	5	7	7	9	12	16
Jet size	natural gas	φ mm	2.4	2.4	2.2	2.4	2.4	2.4	2.4
	prop/but	φ mm	1.35	1.35	1.25	1.35	1.35	1.35	1.35
Gas supply pressure 'P' ¹	natural gas	mbar	(GB) = 17,5 / (IE) = 20,0						
	propane gas	mbar	37,0						
	butane gas	mbar	28,0						
Burner pressure ²	natural gas	mbar	8,50						
Gas consumption @ 15° C, & 1013,25 mbar	NG ³ G20	m ³ /h	3,20	3,90	4,74	5,54	7,00	9,60	12,80
	Butane G30	kg/h	2,10	2,60	3,12	3,64	4,61	6,31	8,42
	Propane G31	kg/h	2,06	2,52	3,05	3,56	4,51	6,18	8,25
Gas connection (not supply line size)			Rc ¾						
Air volumes ⁴ @ 15° C	minimum	m ³ /h	1350	1650	2000	2300	2900	4000	5400
	maximum	m ³ /h	3000	4000	5000	5000	7200	9000	12000
Fan motor rating	minimum	kW	0,18	0,18	0,18	0,18	0,25	0,25	0,25
	maximum	kW	1,1	1,1	1,5	1,5	2,2	3,0	3,0
Electrical service			0,18 - 0,37 kW : 230/240 V 1N ~ 50 Hz 0,55 - 3,00 kW : 400/415 V 3N ~ 50 Hz						
Total electrical rating ⁵	kW	Motor rating + 0,2 kW							
Net weight approximate ⁶	kg	155	188	219		241	295	350	

- 1 Maximum gas pressure at inlet to appliance 50,0 mbar
- 2 All casing panels fitted service door open
- 3 Natural gas G20, caloric heating value 10,5 kWh/m³ on H_s @ 15°C & 1013 mbar
Propane G31, caloric heating value 12,88 kWh/kg
Butane G30, caloric heating value 12,66 kWh/kg
- 4 Isothermic @ 15° C Max Δ T 40 K if higher values are required consult Reznor or their distributor
- 5 During start up period (± 30 s) increased by 900 W not included in these ratings
- 6 Dependant upon options and motors fitted. Selection of motors and drives can be specified within the ranges given. Consult separate brochure for duties and performance.

Figure 1 : Dimensions

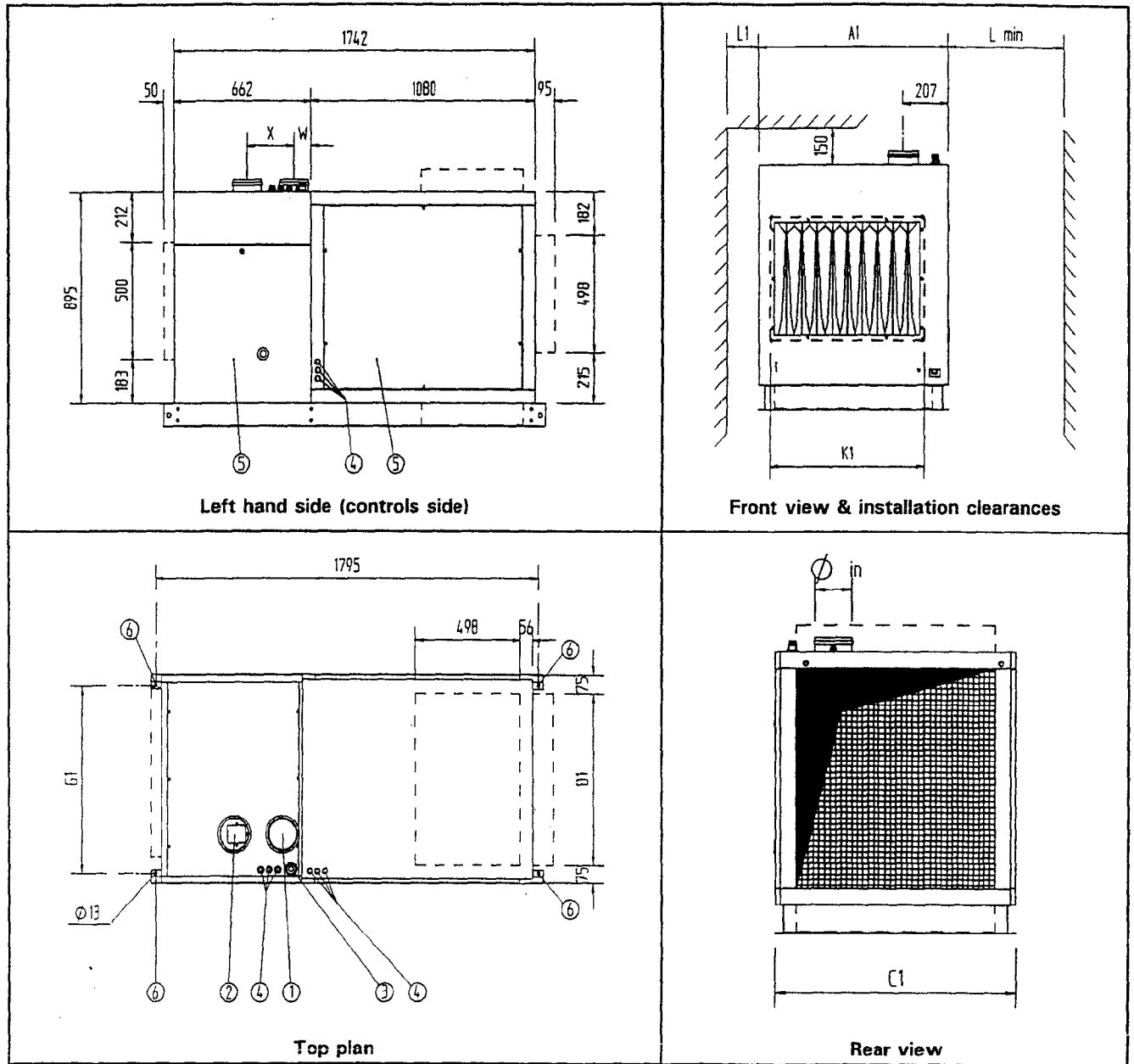

- Legend :
- 1. Combustion air inlet socket
 - 2. Flue outlet socket
 - 3. Gas service connection
 - 4. Electrical & controls inlet points
 - 5. Service access panels
 - 6. Suspension points

Table 2 : Dimensions for figure 1

Model STE	100-2	125-2	150-2	175-2	225-2	300-2	400-2
Dimension							
A1	520	590	730	870	1080	1360	
C1	524	594	734	874	1084	1364	
D1	370	440	580	720	930	1210	
G1	436	506	646	786	996	1276	
K1	360	430	570	710	920	1200	
L1	150				300		
L min	550	620	750	900	1100	1400	
W	167			82			
X	140			225			
φ ID	102			132			

SECTION 3. INSTALLING

- 3.1 Figure 2 shows the clearances necessary to ensure that safety from combustibles and for servicing are maintained. In the event that the appliance is required to be installed on the floor then a non combustible base must be provided.
- 3.2 Ensure that the structural elements which will be used to suspend or support the appliance are adequate to carry the weight of the appliance and its ancillary components i.e. the flue system.
- 3.3 The location where the air heater is to be installed, must provide sufficient space around the heater for servicing and clearances for safety. Beware to allow space for the passage of vehicles i.e. lift trucks, etc.
- 3.4 Ensure that the air heater is installed in a level plain.
- 3.5 The air heater must be fastened securely to any base mount frame work or wall brackets.
- 3.6 Four point suspension is possible from the ϕ 10.5 mm holes provided in the base frame. Using drop rods etc. Ensure that suspension fixings are lock nut secured to guard against loosening. An operating appliance is a live load!
- 3.7 When suspended the air heater should be rigid so as to avoid placing a stain on the flue system and connected services.

Figure 2 : Installation clearances

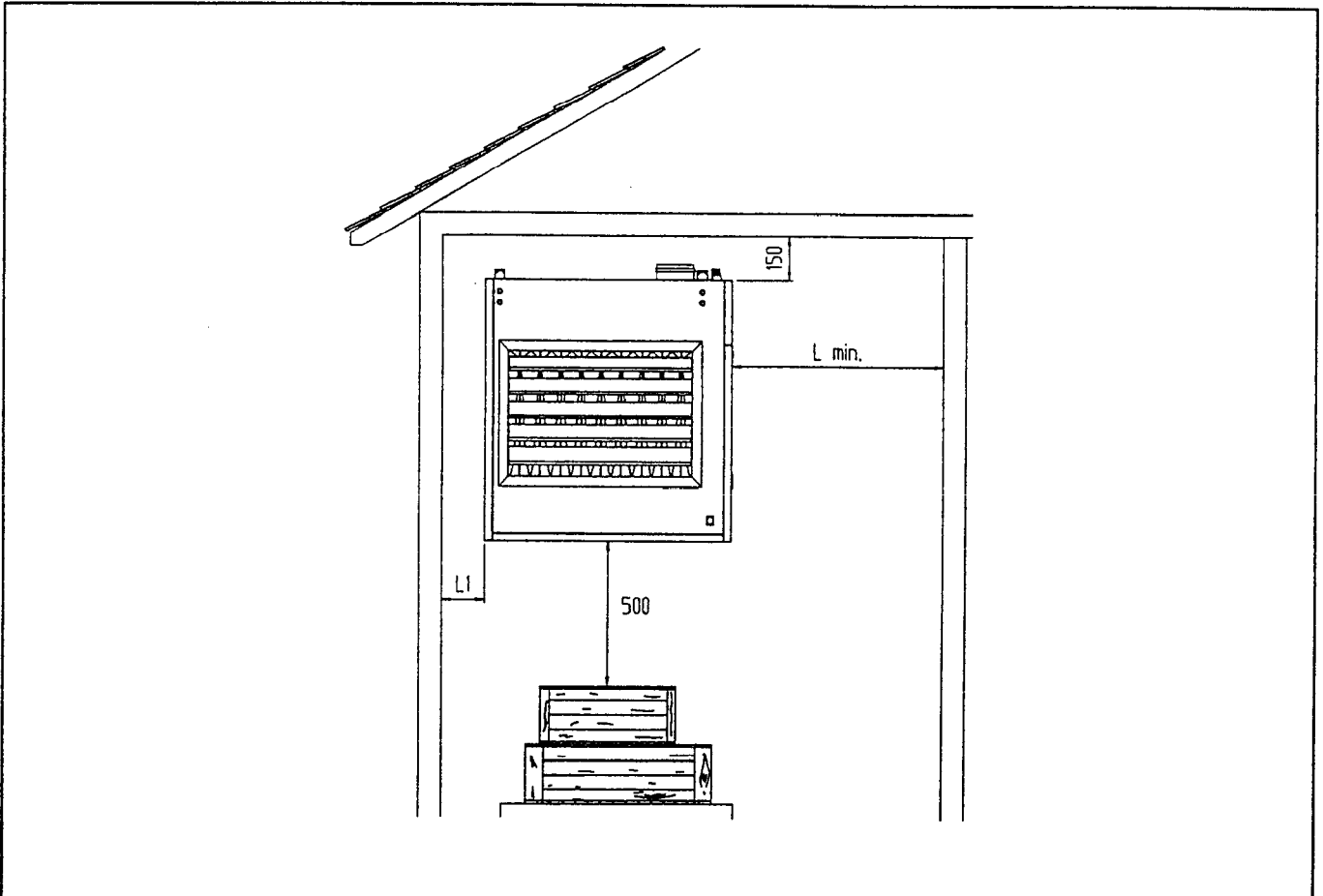

Table 3 : Dimensions re. Figure 2.

Model STE	100-2	125-2	150-2	175-2	225-2	300-2	400-2
L1	150					300	
L minimum	550	620	750		900	1100	1400

3.8 When transporting the appliance after it has been unpacked i.e. For lifting etc. Note the restrictions and recommendations indicated in figure 3.

3.9 The base frame contains an internal support member which acts as a lifting fulcrum point to prevent damage to the underside of the appliance by lifting forks.

Figure 3 : Appliance handling criteria

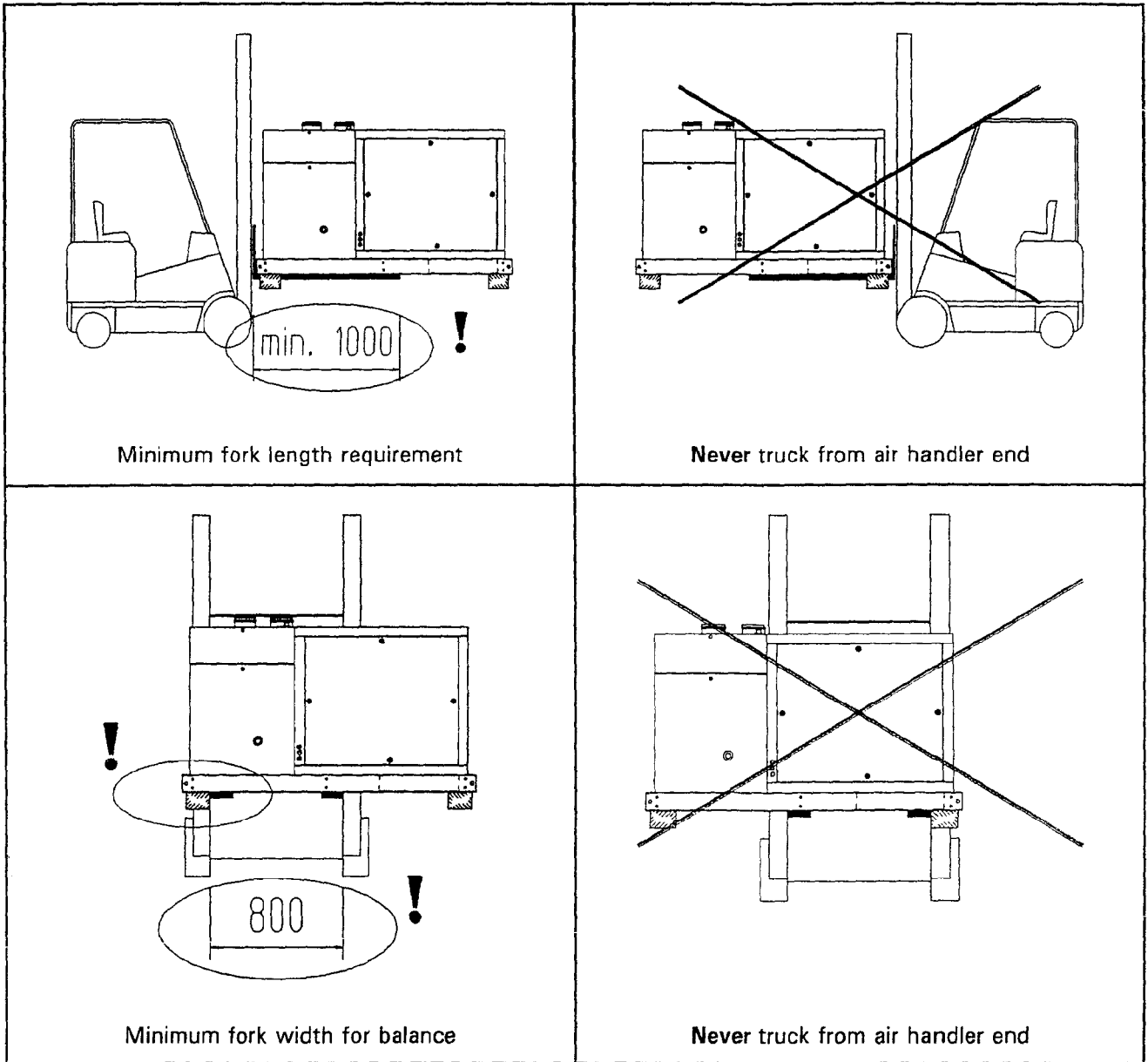

3.9 DUCT CONNECTIONS

The STE Series 2 air heaters are designed to be used in conjunction with intake and or discharge ducting. A positive seal should be made between any ducting and the air heater. A flexible connection is desirable to eliminate transmission of noise and to take account of thermal expansion.

Figure 4 illustrates a method of connection between the appliance and the duct using a proprietary patented connection system.

3.10 Consideration should be given to the application of duct fittings directly connected to the appliance. Air inlet and outlet elbows, transitions etc. should be designed to ensure an unrestricted and turbulent free air flow. This requirement is to ensure that an even air temperature is maintained when leaving the appliance thus eliminating heat exchanger "hot-spots" and nuisance shut-down of the burner due to over heating.

Figure 4 : Recommended procedure and method for connection of ductwork and transitions to the air heaters using a typical proprietary flange system.

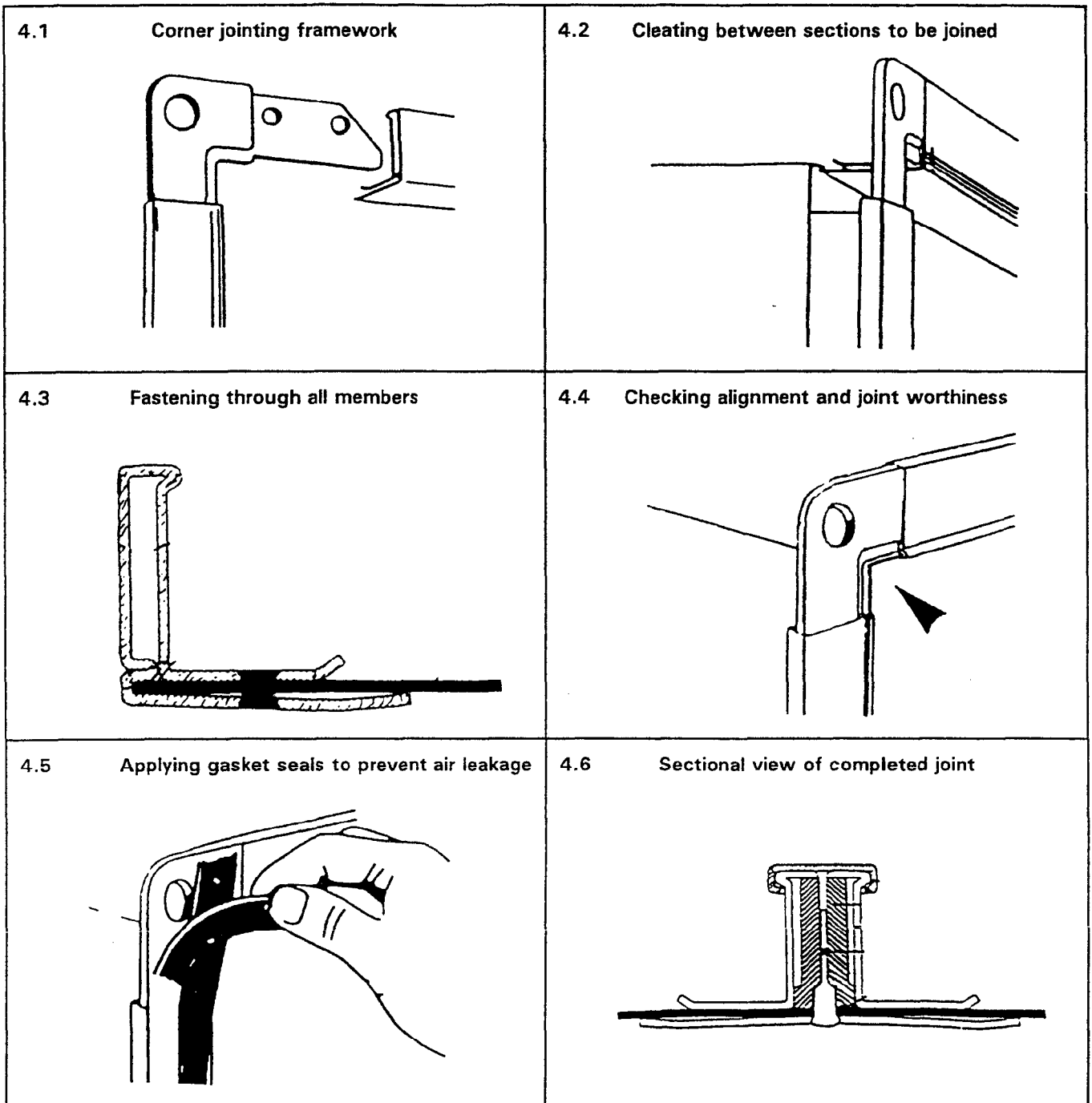

Legend :

- | | |
|---|---|
| 4.1 Cut and assemble flange into frame to suit opening | 4.4 Checking location after positioning |
| 4.2 Check dimensions and position on duct spigot | 4.5 Applying sealing gasket |
| 4.3 Ensuring flange is mated correctly before fastening | 4.6 Sectional view of completed joint |

SECTION 4. COMBUSTION AIR SUPPLY AND FLUE SYSTEM

- 4.1 Flue systems must comply with national and local regulations.
- 4.2 The products of combustion must be flued to outdoor atmosphere. Common flues for more than one appliance must **NOT** be used.
- 4.3 Combustion air should be taken from out-door atmosphere, this improves the operational efficiency of the heating system.
- 4.4 Flues and combustion air ducts where connected to the air heater must incorporate a disconnect section adjacent to the appliance to facilitate removal of the venter assembly for service and replacement purposes. The flue system must therefore, be supported independently.
Where flue systems are taken through elements of air handling appliances then provision must be made to allow servicing of the flue gas fan assembly. This will entail fitting a detachable transfer section from the appliance flue and combustion air connection sockets to the outside of the appliance. The main flue should then respect the criteria outlined below.
- 4.5 Dimensions and allowances in suggested flueing and combustion air intake arrangements are based upon the use of smooth wall aluminium flue and combustion air ducts and fittings equipped with positive sealing gaskets.
- 4.6 Type C Appliances
- 4.6.1 When using the concentric termination as figure 5 arrangements, then only the approved system using Ambi-Rad components may be used. These items are manufactured from seamless aluminium with connection sockets fitted with silicone double edged seals, thus assuring, if the components are undamaged, leak free flue systems.
Important: This type of flue/Combustion air intake system is regarded as an integral part of the air heater therefore, departure from the methods of flueing as published in this document is in breach of the EC Gas Appliance Directive.
- 4.6.2 Distances between the appliance and the concentric flue termination must not be greater than 9.0 m. When calculating the total length the following equivalent length data must be taken into account:
- 1 elbow @ 45° = 1 m
1 elbow @ 90° = 1,5 m.
- 4.7 Type B Appliances
- 4.7.1 If the air heater is to be installed as a B type appliance as figure 6 i.e. air for combustion to be taken from within the space to be heated, then it must be ensured that an adequate air supply for combustion and ventilation is provided, in accordance with the regulations and rules in force.
- 4.7.2 A horizontal distance between air heater and flue terminal and any combustion air intake duct, must not be in excess of 16 m.
Note: 2 Meters of vertical rise negates the resistance imposed by 1 meter of horizontal run.
Runs exceeding 16m may be subject to condensation forming within the flue for which provision for its removal must be made.
Equivalent lengths of flue fittings:
- Elbow @ 45° = 1 m
Elbow @ 90° = 1,5 m.
Flue terminal ≤ 3.0 m
- 4.7.3 To ensure that the allowable resistance is not exceeded in the case of horizontal runs of flues, a positive rise from the air heater of 1° i.e. 17 mm per metre is recommended.
- 4.7.4 If condensation is to be avoided, flues should not pass through cold areas or not be installed externally.
- 4.7.5 When mechanical ventilation is used, it shall be by mechanical inlet with either mechanical or natural extraction. Automatic means of control such as interlocks must be provided. The function of other ventilation systems in the zone where the air heater is installed must be taken into account. At no time should it be possible to create a negative pressure environment in the zone, this can lead to a hazardous situation, whereby the air heater flue may act as a pressure relief.
- 4.7.6 The terminal of a vertical flue must extend at least 1 m above a roof surface; flues must not be located where products of combustion might enter the building. Terminals suitable for power vented appliances must be fitted to all flues.
Note: The combustion air inlet if not used must be protected with an access guard.

Figure 5. Flue systems when installed as type C 'room sealed' appliances

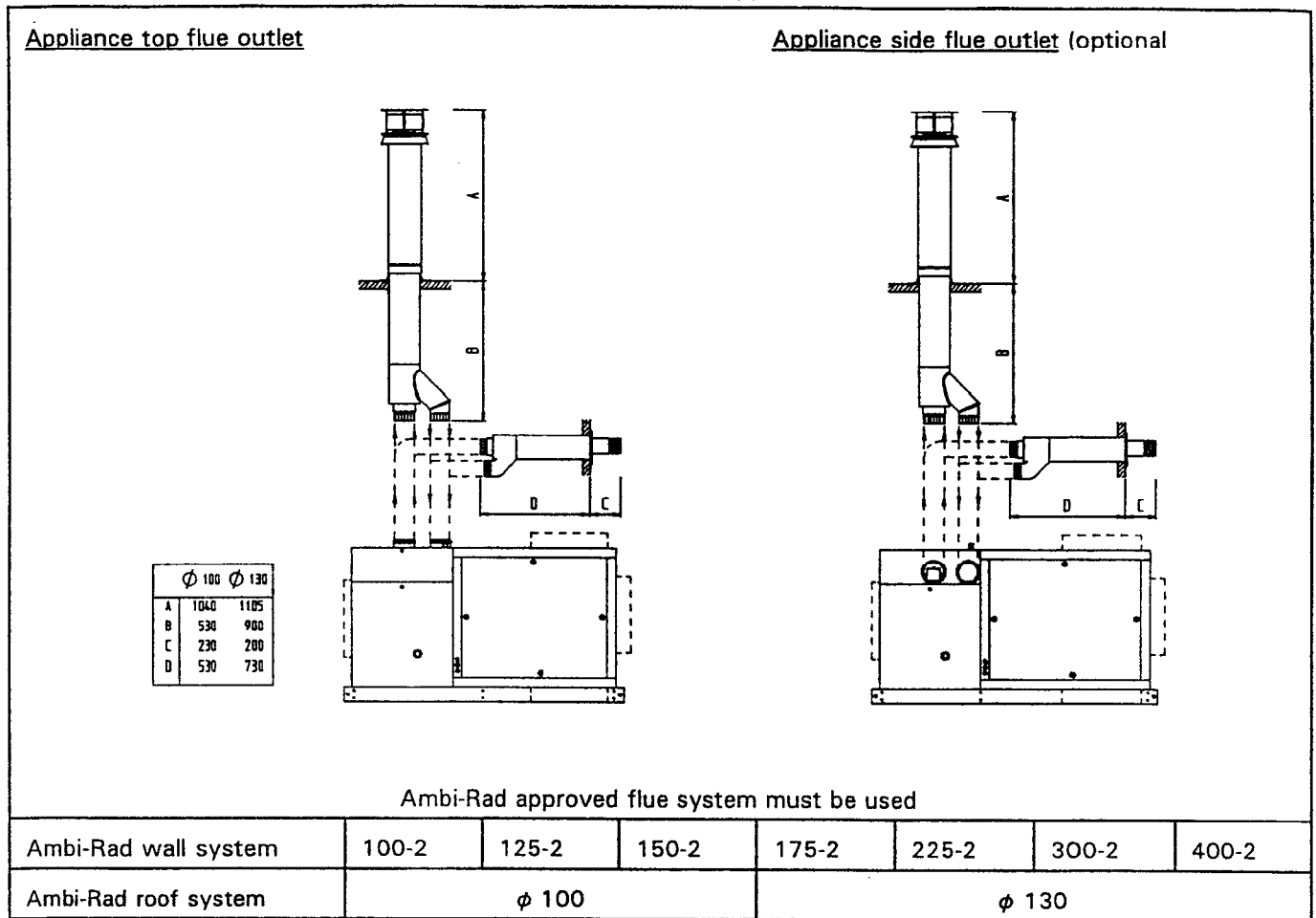
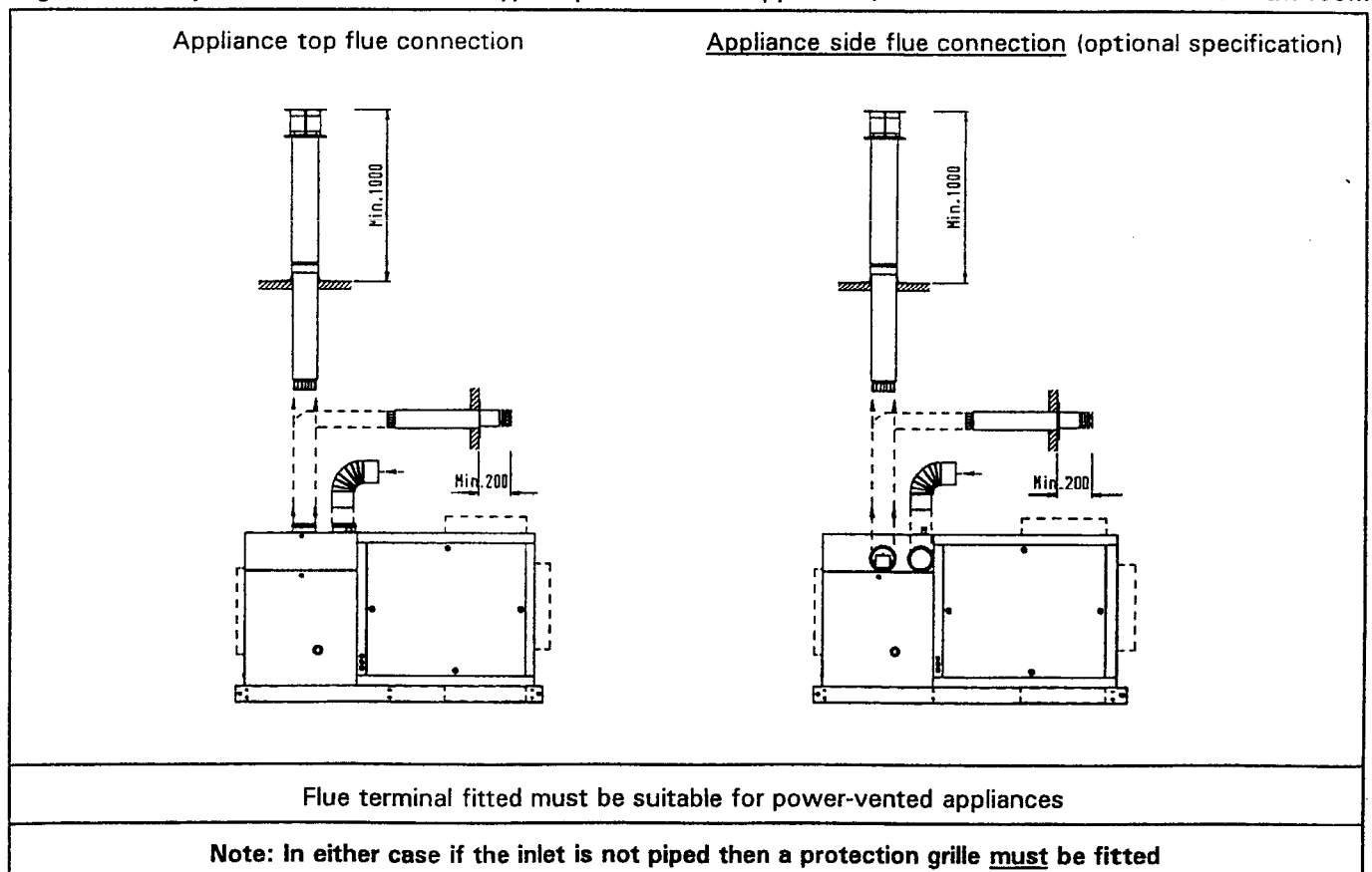

Figure 6. Flue systems when installed as type B 'power vented' appliances, with combustion air from within the room



SECTION 5. GAS CONNECTION

- 5.1 Connection to a gas service may only be carried by suitably qualified persons. The gas installation must comply with the rules in force using materials appropriate for gas service installations.
- 5.2 Check that the gas category is in accordance with the data described on the air heater.
- 5.3 An adequate gas supply sized to provide the dynamic pressure for the volume required by the air heater(s) is essential to maintain the nominal heat input.
- 5.4 A 90° action gas service tap and, to facilitate servicing, a disconnect union fitting must be provided adjacent to the appliance, see fig. 7.
- 5.5 Ensure that a gas service includes a filter and has been tested and purged in accordance with prescribed practice prior to commissioning and taking the air heater into service.

Fig. 7 GAS CONNECTION DETAIL

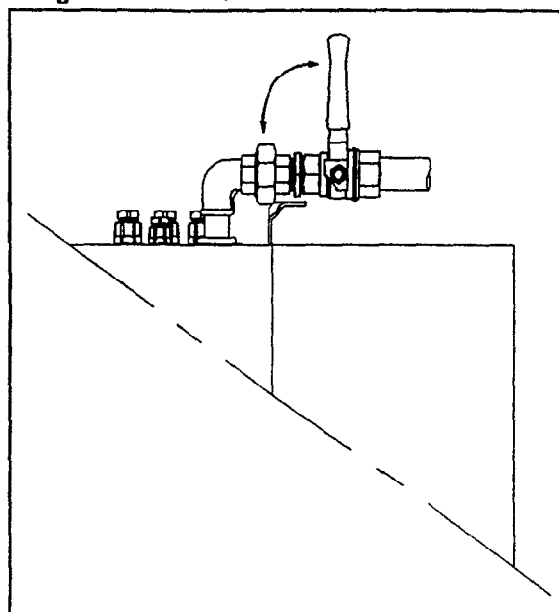

WARNING: NEVER use a FLAME to test for GAS Soundness !!!

SECTION 6. ELECTRICAL CONNECTION

- 6.1 The Electrical installation may only be carried out by suitably qualified persons observing the rules in force.
- 6.2 Check that the electrical specification is in accordance with the specified data on the air heater. A unique appliance wiring diagram is supplied as a separate document attached to this one plus an additional copy attached to the air heater.
- 6.3 These appliances must be earthed.
- 6.4 A separate electrical isolator for each heater must be provided adjacent to the appliance. The isolator must have a contact separation of at least 3.0 mm on all poles.
- 6.5 Ancillary controls are required to provide timed heat cycles, room comfort temperature level, frost protection, override air circulation etc. These are not included with the appliance and should be ordered separately.
- 6.6 Ensure when planning the external appliance control circuitry, that power will be supplied at all times to the air heater, even when it is control switched in the 'heat-off' mode. This is necessary to ensure that the fan can operate independent of the heating control. Therefore, **Never** incorporate automatic controls that electrically isolate the appliance.

NOTE: STE AIR HEATERS ARE SUPPLIED WITH EXTERNAL CONTROL CIRCUITS BRIDGED. THE AIR HEATER/S WILL OPERATE CONTINUOUSLY UNLESS THESE ARE REMOVED AND TIME AND TEMPERATURE CONTROLS SUBSTITUTED FOR THEM

- 6.7 The centrifugal blowers fitted to STE series 2 air heaters are of the forward curved type therefore, the speed setting for the static pressure imposed by the air distribution system will govern the motor loading. All STE air heaters leave the factory with the drives set to the specified conditions of the appliance. Table 5 provides the motor characteristics for the various sizes.
- 6.8 Refer to section 7 to learn how to carry out adjustments necessary to alter the fan speed and motor load factors.

Table 4 : Maximum motor load ratings

Motor rating	kW	0.18	0.25	0.37	0.55			0.75			1.1		1.5	
Phase	~	1	1	1	1	3	3	1	3	3	3	3	3	3
Voltage	V	230	230	230	230	230	400	230	230	400	230	400	230	400
Load rating	A	2.3	2.3	2.8	3.9	2.4	1.4	4.7	3.1	1.8	4.5	2.6	5.0	2.9

SECTION 7. COMMISSIONING, LIGHTING AND OPERATION

COMMISSIONING

7.1 Final testing after production ensures that: If installation has been carried out strictly in accordance with this document, the appliance is ready to be taken into service.

7.2 Checks must be made to ensure :

- earth continuity
- resistance to earth
- phase supply to correct terminals
- current rating and fuse value
- correct supply gas pressure
- correct burner gas pressure
- satisfactory & smooth ignition
- Flue system is evacuating the products of combustion to outdoor atmosphere

7.3 In addition to the above requirements checks to ensure that the fan performance and motor load factors are correct for the application and in accordance with the appliance data plate.

7.4 Drives general and adjustments

7.4.1 The drive assembly of STE air heaters is guard protected to class IP20. Adjustment may be necessary to set the fan duty for the static pressure and motor load requirements. It is necessary to remove the guards prior to making adjustments. Before commencing work on the fan assembly:

- Set external controls to off or their lowest setting.
- Turn **OFF** the gas supply to the air heater.
- Switch **OFF** the electricity supply to the air heater after the air circulating fan has stopped.
- Remove protection guards as necessary and carry out adjustments as appropriate.
- Before placing the appliance back into service or switching the fan on ensure that all protection guards are replaced and secured.

N.B. Rotational speed checks should be carried out using an infra red tachometer or stroboscope.

7.4.2 Adjusting the fan speed can be carried out by altering the diameter of the adjustable drive pulley.

- Loosen the belt tension device and remove the drive belt.
- Refer to figure 8 and note that the outer section of the drive pulley is secured by a hexagon socket grub screw to a flat on the pulley hub, this is positioned by loosening the grub screw sufficiently to enable the pulley to be either opened or closed by turning it on the thread on which it is engaged.
- It should be noted that one complete turn of the pulley half is equal to approximately 8% of the fan speed. Closing the pulley increases the speed and opening decreases the speed.
- after making speed adjustments tension belt in accordance with the dimensions given in figure 7 and check pulley alignment to ensure the belt runs correctly.

N.B. Always ensure that the pulley is tightened onto a flat of the hub before switching on the fan, even when testing a reset condition.

7.4.3 **Caution!**

Opening the pulley too far will cause the belt to touch the bottom of the V groove resulting in greatly reduced belt life and loss of grip.

7.4.4 If the amount of adjustment is not achieved with the range obtainable with the pulleys fitted, it will be necessary to change the driven pulley fitted on the blower and possibly the size of the drive V belt. **After adjustment ensure the motor load rating is not exceeded!**

Figure 8. Pulley & drive belt adjustment

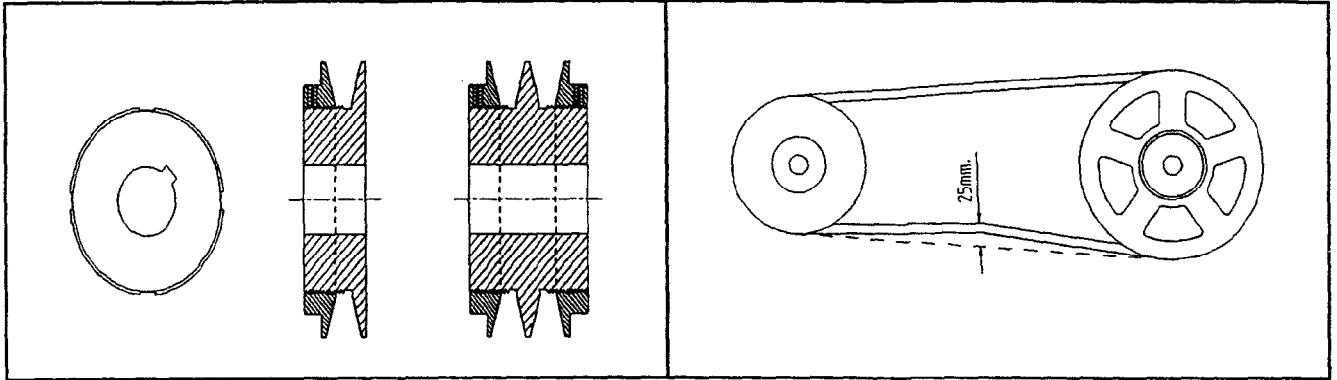

7.5 LIGHTING

- Ensure that air discharge louvres are set to open.
- Turn on gas supply.
- Switch on electrical supply.
- Set time switch (if fitted) to an 'ON' cycle.
- Set room thermostat to 'ON' position.
- If reset button on heater and/or on remote control (if fitted) glows, press reset button.
- Heater should now light automatically within 2 minutes. after a further period the air circulation fan should run. (see also below: "operation" point 7.6.6).
- For a new installation or if the appliance has been turned off for an extended period then up to 3 attempts to light the air heater may be necessary. If the heater still does not light, consult the fault finding guide section 9.

7.6 OPERATION Refer to figure 12.

- 7.6.1 At the dictates of the external controls, an electrical circuit is made and the combustion air fan ("venter") runs.
- 7.6.2 Provided adequate air flow is proved, the fan will continue to run approximately 30 sec. (pre-purge period).
- 7.6.3 STE air heaters employ the direct burner ignition principle. A hot surface igniter will glow for ± 15 seconds, after which time the gas valve(s) will open and the burner will be lit.
- 7.6.4 If the burner has not lit within 5 seconds, the electronic flame relay will switch off and lockout will occur. This will cause the signal lamp to glow within the reset switch on the appliance and/or a remote control if fitted). After 10 seconds the reset button on the appliance or the remote control can be operated in order to reset the appliance.
- 7.6.5 Flame failure protection is by the ionisation principle i.e. the ability of a suitable flame to pass an electrical current between the igniter and the earthed burner assembly. To check the flame current is adequate, remove jumper

between terminal 17 and 18 on the automatic burner control, connect a DC micro ammeter between the terminals. Ionisation current should be $\geq 2\mu A$.

Note: The terminals carry mains voltage when energised.

- 7.6.6 Simultaneously to the ignition circuit and gas valve circuit being energised, electrical power is supplied to an anticipator within the air circulation thermal fan control. The air circulation fan will start after about 2 minutes and warm air at a temperature of approximately $40^{\circ}C$ is now discharged from the appliance.
- 7.6.7 In the event of the combustion air volume falling below a safe level, the burner will be extinguished a re-start cycle will commence after adequate combustion air volume has been restored.
- 7.6.8 If the burner flame is extinguished for any reason during a run cycle, an automatic attempt for re-ignition will take place, if the burner does not relight then safety shut down and lockout will occur. Manual intervention to reset is necessary to put the air heater back into service.
- 7.6.9 In the event of overheating for any reason, thermally activated fail safe overheat controls operate to switch off the burner. The first control (LC1) switches off the burner and upon its cooling, automatically resets and the lighting sequence starts automatically. The second control (LC3) which operates at a higher temperature setting, will switch off the burner and itself set to a lockout condition which also requires manual intervention to reset to restore the heater to operational condition. A cooling time of ± 1 minute is necessary before thermal re-setting can be carried out

7.6.10 When the set temperature or the heating time period has been reached, electrical power to the burner relay will be switched off and the burner will extinguish. The air fan will continue to run until the heat exchanger has been cooled down to a safe level.

7.6.11 To turn off the air heater for a short period,
a. turn room thermostat to lowest setting.

To relight reset thermostat.

For prolonged period;

- a. turn room thermostat to low setting,
- b. turn gas supply to the appliance off.
- c. switch off electricity supply to the air heater **after air circulation fan has stopped.**

To relight follow lighting instructions.

7.6.12 The gas service tap must only be operated in emergencies, for servicing or prolonged periods of shutdown of the air heater.

SECTION 8. MAINTENANCE

8.1 General

Before commencing servicing, turn off the main gas supply and switch off the main electricity supply **after the air circulation fan has stopped.**

8.2 It is recommended that maintenance is carried out at least once a year. More frequent servicing may be required dependent upon the environmental circumstances where the air heater is installed. Regular inspection is necessary, especially in dirty areas, to assess the servicing frequency.

8.3 Check condition and security of flue and combustion air system.

8.4 Check for security and worthiness of the suspension or mounting system.

8.5 To gain access to the controls and flue gas fan assembly.

8.5.1 For appliances fitted with vertical flue systems, follow the four step procedure:

- 1. Unlatch cam fastener $\frac{1}{4}$ turn counter clockwise on controls compartment access panel.
- 2. Remove access panel.
- 3. Unscrew retaining screw at top of upper cover panel.
- 4. Upper panel can now be removed by pushing upwards 2 cm to disengage panel retaining lugs and then lifted away.
- 5. The flue installation should include a service access section adjacent to the connection socket allowing access to the top of the flue fan. In the event that the fan housing assembly requires removal i.e. for replacement, then it is necessary to remove that section to access the 4 securing screws that fasten the fan housing through the top of the appliance. All controls, electrical and flue gas components are now accessible.

8.5.2 For appliances fitted with horizontal flue systems: follow steps 1 & 2 above and then;

- 1. Disconnect flue and combustion air inlet pipes at the section provided. Ensure that the pipes will remain supported when disconnection has been made.
- 2. Remove 4 sheet metal screws securing the venter fan to the upper cover panel.
- 3. Follow steps 3 & 4 9.5.1 above.

8.5.3 To replace reverse order above as appropriate.

8.6 If it is necessary to remove the cabinet top panel to gain access to the flue products collector box or the top of the heat exchanger, it is necessary to refer to figure 9:

- 1. Isolate and disconnect the electrical and external controls wiring that passes through the panel.
- 2. Isolate and disconnect the gas service to the air heater.
- 3. Remove all of the sheet metal screws that secure the top panel to the appliance and remove panel as required.

8.7 Remove all dust and dirt from the combustion air fan (venter) see figs. 11 & 12. If dismantling venter observe critical dimensions before reassembly.

8.8 Check that air circulating fan guard is undamaged and secure.

8.9 Check security of the fan blade and fan motor.

Note: The fan motor is lubricated for life and does not require lubrication.

- 8.10 Inspect hot surface igniter (fig. 13) - replace if in doubt about its condition. **Note: The Igniter device is fragile, therefore, handle carefully**
- 8.11 Inspect and clean the burner assembly, refer to fig.14
- 8.12 Inspect heat exchanger and clean as necessary. This can only be done after removing the burner assembly.
- 8.13 After removal of burner assembly, each element of the heat exchanger can be cleaned by use of a soft brush and compressed air. Clean both inside and the outside surfaces.
- 8.14 Clean burners and gas jets with soft brush and compressed air. To prevent damage, do not use hard objects for cleaning the gas injectors.

- 8.15 If anchor lines of service panels are removed during servicing, they must be refitted upon completion of the service.
- 8.16 Upon completion of any service work it is necessary to recommission the appliance in accordance with the step procedure described in section 7.2 of this document.
- 8.17 To remove the combustion air fan:
 1. Disconnect electrical connections to fan motor
 2. Remove motor and fan wheel 3 screws
 3. Withdraw motor/impeller assembly sideways
 4. Clean fan housing
 5. Check, clean or replace motor and/or fan wheel
 6. Replace in reverse order after checking dimensions (fig. 11 & 12).

Figure 9 : Service access keys

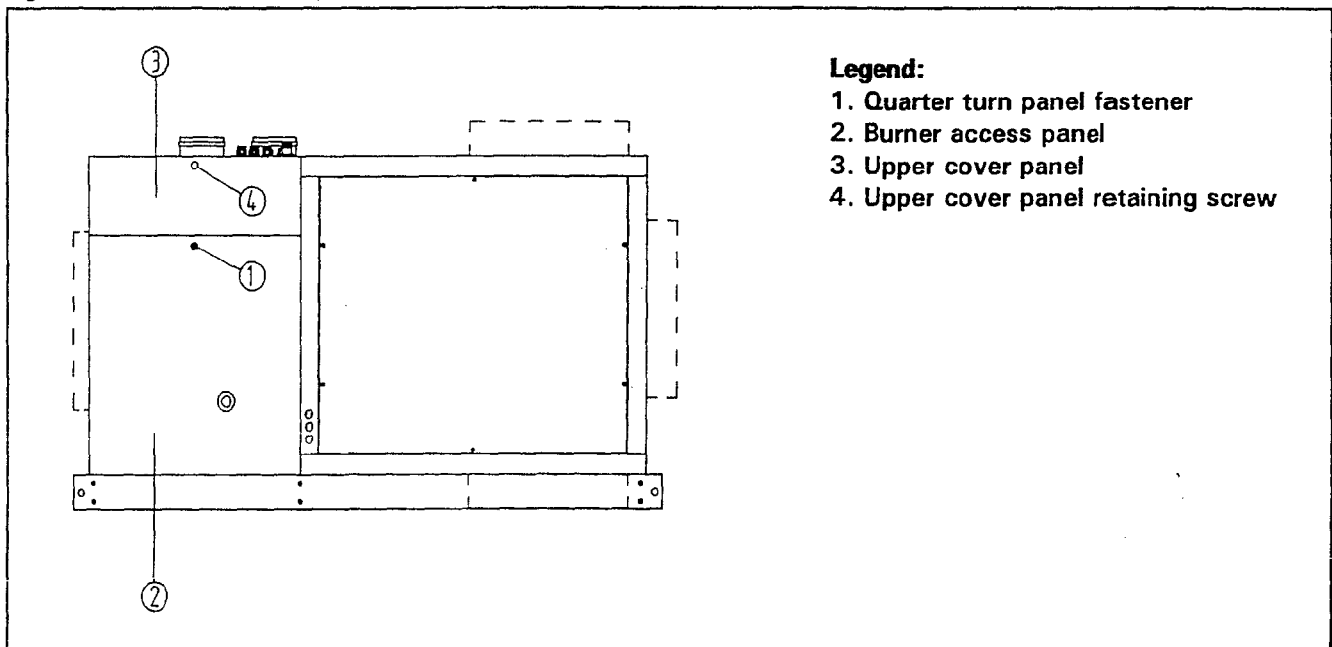

Figure 10 : Top panel removal keys

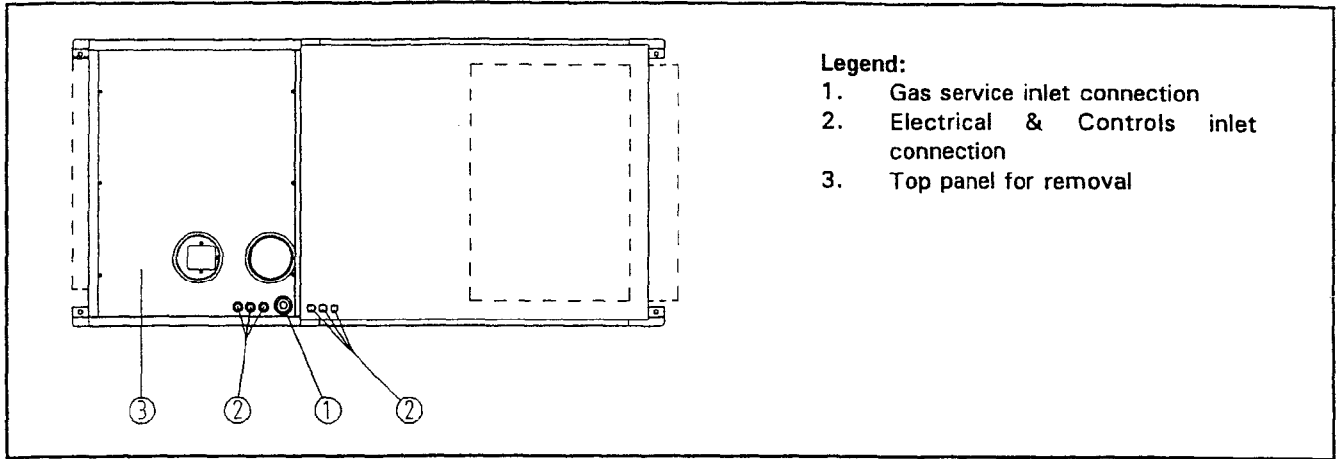

Figure 11 : Removal of the combustion air fan (VENTER) motor fan impeller assembly

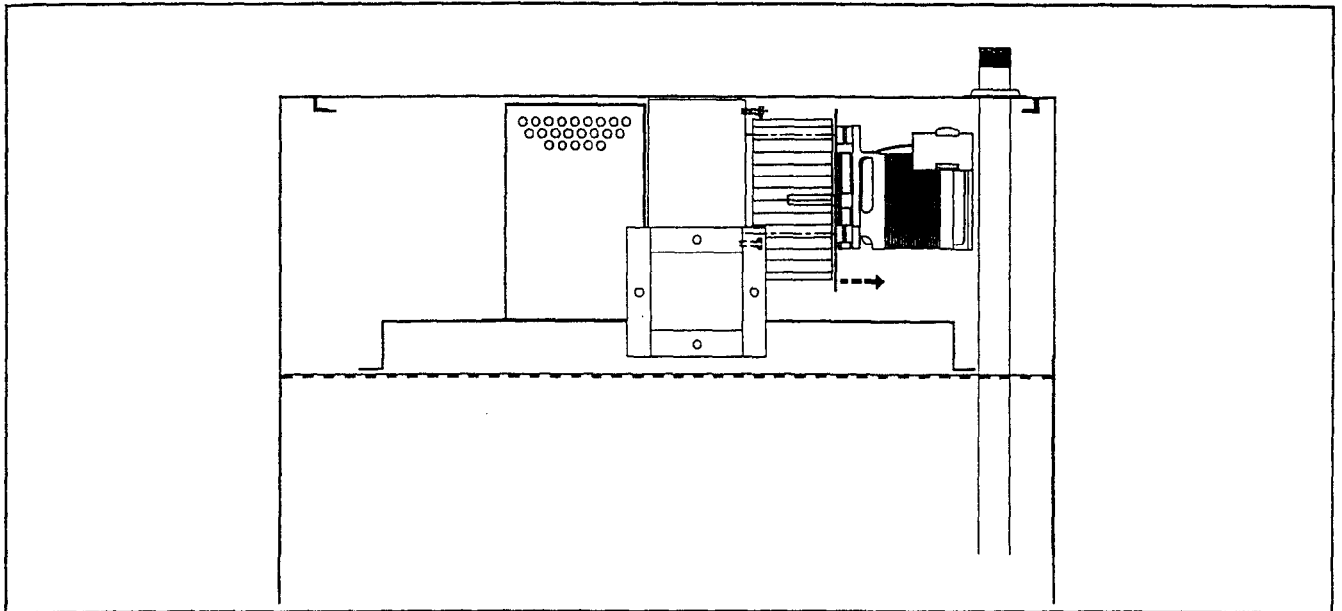

Figure 12 : Critical fan dimensions

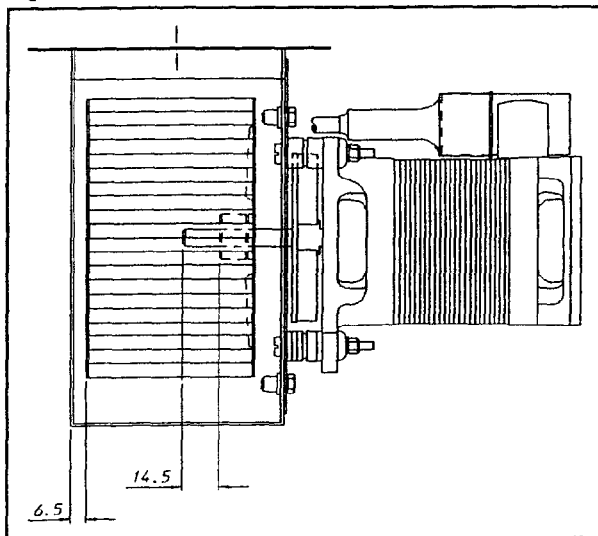

Figure 13 : Igniter/sensor assembly

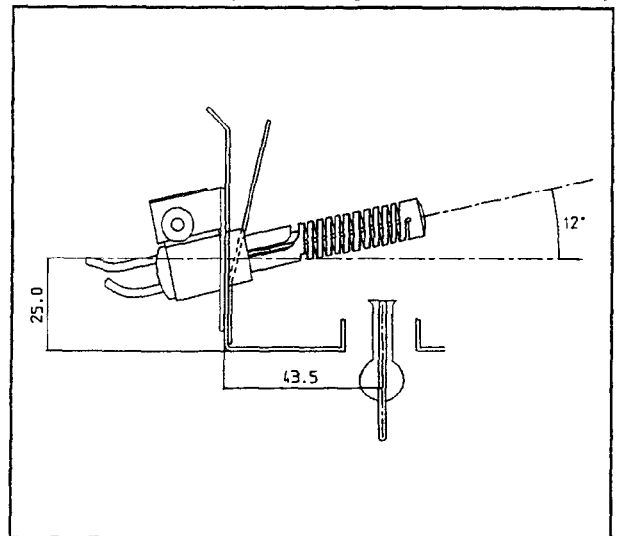
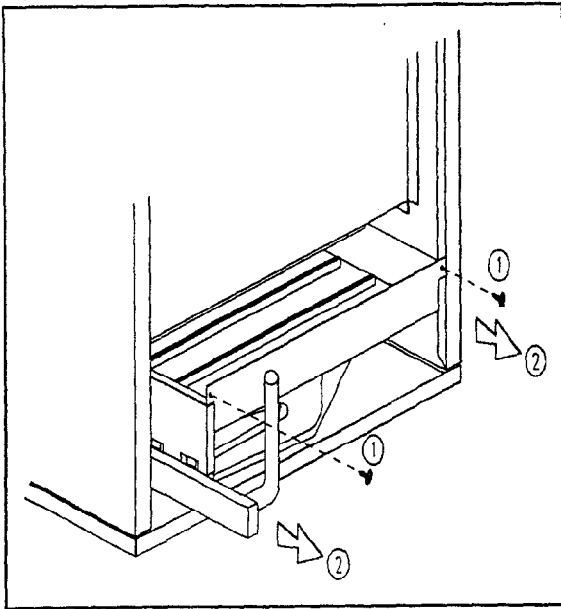

Figure 14 : Removal of the burner assembly



8.18 Guide to remove the burner assembly:

1. Turn off the main gas supply
2. Switch off the main electricity supply **after the air circulation fan has stopped**
3. Open service panel figure 9
4. Disconnect wires to igniter
5. Disconnect union fitting between gas valve(s) and burner
6. Unscrew 2 fixing screws securing the burner and pull forward the assembly on its slide rails
7. To replace reverse the above order

8.19 Air filters

STE air heaters have an optional facility for air intake filters.

Standard rack/supports are provided to accommodate 25 mm nominal thickness filter elements.

Unless otherwise specified filters supplied will be metal frames complete with fibre-glass elements. The sizes and quantities required to suit individual appliances are listed in table 5.

N.B. Part numbers indicated are for replacement fibre-glass elements only (not frames).

Table 5 : Filter size and quantities schedule

STE Model size	Filter element size mm X 25 mm nominal thickness			Ambi-Rad part number 25mm fibre-glass elements
	Quantity required	Length	Width	
100-2	2	622	394	
125-2	2	622	495	
150-2	2	597	597	
175-2	2	597	597	
225-2	4	622	394	
300-2	4	622	495	
400-2	2	622	495	
	4	622	394	

(consult Ambi-Rad for alternative filters or see addendum sheet)

Figure 15 : Component parts lay-out

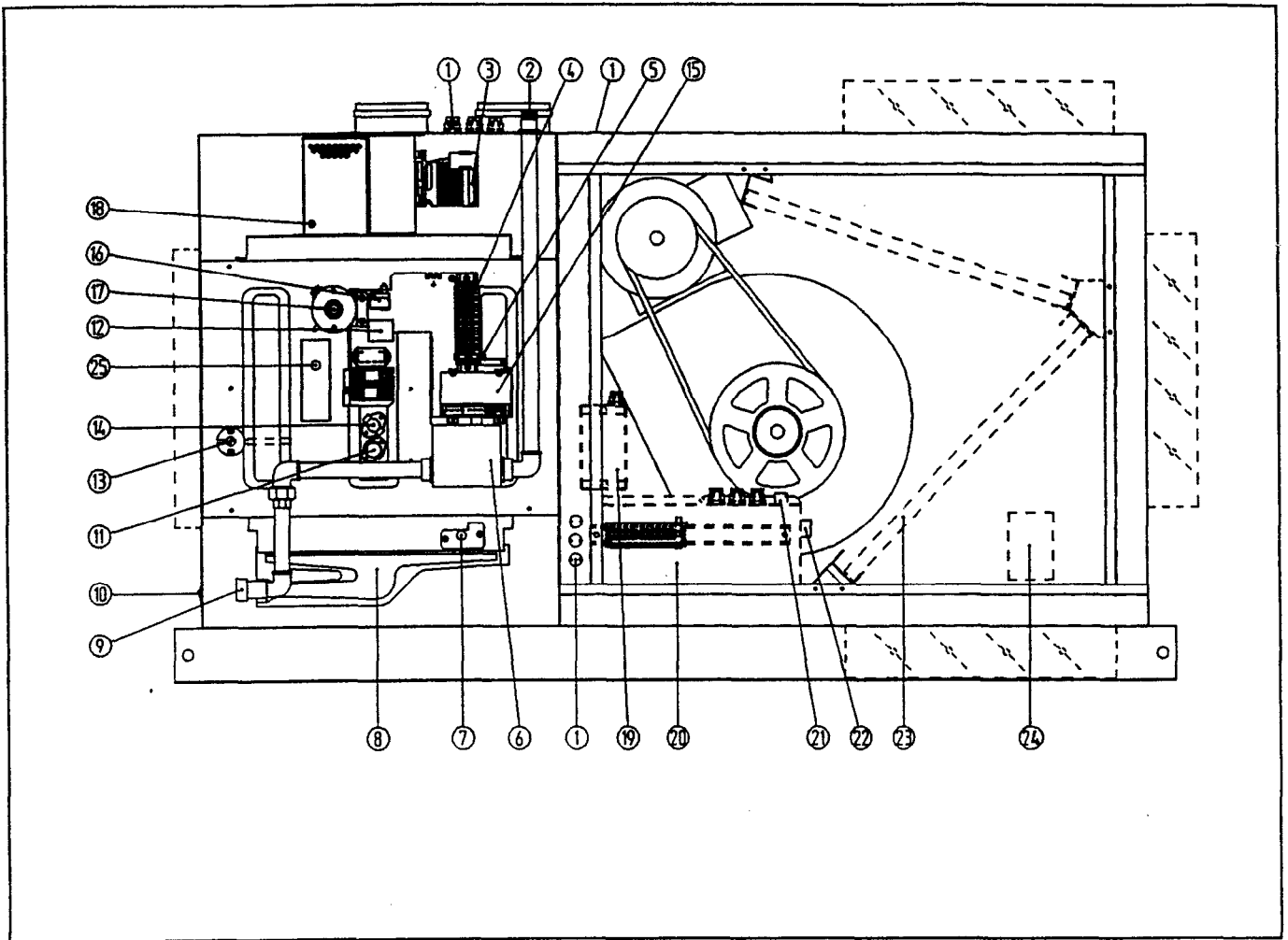

Legend :

- | | |
|--|--|
| <ul style="list-style-type: none"> 1. Cable entry all electrical connections 2. Gas connection Rc ¾ (not supply line size) 3. Combustion air fan with motor 4. Wiring terminals for all electrical & controls 5. Appliance fuse 6. Multi-functional gas valve including governor 7. Hot surface igniter 8. Burner tray assembly 9. Gas manifold, injectors & test point 10. Burner lockout indicator/reset switch 11. Thermal fan control (FCR) 12. Isolation transformer (not GB) 13. Capillary for thermal overhear control (LC3) | <ul style="list-style-type: none"> 14. Thermal overhear control (LC1) + LC2 on two fan models 15. Electronic burner control 16. Thermal overhear control (LC3) 17. Differential air pressure switch (flue gas) 18. Flue gas sample test point 19. Motor starter/overload 20. Supplementary wiring box for ancillaries 21. Connection for air proving device 22. Connection for filter clean indicator 23. Air filters 24. Servomotor for air control dampers 25. Duct sensing thermostat |
|--|--|

N.B. THE APPLIANCE WILL ONLY OPERATE WITH ALL PANELS CORRECTLY FITTED!!

SECTION 9. FAULT FINDING

9.1 Burner does not ignite

- Thermostat set too low or time switch not correctly set; no power to terminals 2 and 5.
- Fuse F3 has blown; no power to terminal 2 and LC3.
- Reference tube to differential air pressure switch S3 is not airtight or blocked.
- Faulty differential air pressure switch S3; no power to terminals 2 and 13.
- Insufficient differential pressure in flue pipe system; Flue blocked or too long.
- Burner relay in lockout (point 2 below) or faulty.
- Faulty combustion air fan M3 (venter).
- Faulty limit control LC1; no power to terminal 2 and LC1.
- Overheat control LC3 in lockout; no power to terminal 2 and LC3; Reset manually.

9.2 Flame relay in lockout

- Air in gas service; purge.
- Low gas pressure.
- Faulty hot surface igniter.
- Faulty differential air pressure switch.
- Gas valve does not open; no power to terminals 2 and 7.
- Insufficient ionisation flame current; ionisation current $\geq 2\mu\text{A}$.
- Incorrect wiring of mains input line, neutral, earth.

9.3. Combustion air fan (venter) does not start

- Faulty motor or capacitor.
- Faulty burner relay.
- Differential air pressure switch S3 still in normal run position no change-over.
- Faulty fuse F3.

9.4 Differential air pressure switch switches burner off

- Switch-point should be; ON 0,99 mbar, OFF 0,94 mbar, type 150-2 : ON 0,74 mbar, OFF 0,69 mbar
- No differential pressure in flue gas system; check flue and air inlet.
- Faulty combustion air fan or capacitor.

9.5 Appliance does not provide sufficient warm air

- Check gas inlet pressure.
- Check burner pressure.
- Gas filter (if fitted) dirty or blocked.
- Limit control (LC1) switches burner off (see 8.6).
- Differential pressure switches relay off (see 8.4).

9.6 Limit control LC1 switches burner off

- Switch temperature 51,5°C, 225-2 → 400-2 top connection : 63°C.
- Insufficient air flow.
- Vertical and horizontal louvres set in closed position.
- Burner overload, check burner and inlet gas pressure.
- Fan control switch faulty
- Check fan rotational direction.
- Air temperature at fan inlet too high; T max. 30°C (see 8.6).
- Thermal contact in fan motor switches off intermittently.

9.7 Limit control LC3 switches

- Switch temperature 96°C (+0/-5).
- Check location and security of capillary and probe.
- Air discharge temperature too high (see 8.6).
- Faulty limit control LC1.
- Air fan stops immediately after burner is switched off; incorrect control/s wiring.
- Faulty fan control (FC).

9.8 Air fan does not start

- No power to terminals 2 and 11.
- Faulty fan control (FC).
- Faulty motor or capacitor.
- Thermal over-load in motor switching.

9.9 Fan starts and stops intermittently while burner is on.

- Faulty heat anticipator (FCR) in fan switch.
- Thermal over-load in motor switching.
- Inlet ambient air temperature too low; T min. <5°C.; will correct as space temperature rises.
- Faulty wiring connection; loose terminals!

SECTION 10. SPARE PARTS LIST STE SERIES 2

10.1 GAS SECTION

DESCRIPTION	PART NUMBER	MFGS.REF.	APPLICATION
Gas valve single stage burners	03 25250	SIT 830 Tandem	STE 100-150
Gas valve single stage burners	03 25136	H'well VR4601AB	STE 175-400
Gas valve two stage burners	03 35136	H'well VR4601BP	Two stage options

10.2 ELECTRICAL SECTION

DESCRIPTION	PART NUMBER	MFGS.REF.	APPLICATION
Thermal fan control fcr	03 25166	TOD29T12 (250V)	All
Thermal over-heat control (limit) LC1/LC2	03 24970	TOD60T11	All
Thermal over-heat control LC3	03 24959	limit 96° C	All
Combustion fan motor	11 43426 01	Drouard-tec CP 78	All
Combustion circuit pressure switch	30 30612	Huba 604	Models 100-150
Combustion circuit pressure switch	30 60612 35	Huba 604	Models 175-400
Automatic burner control	03 25316	Honeywell S4570LS	All
Hot surface igniter assembly	05 25213	Carborundum	All
Two pole relay K1.2	30 61738 240V	Omron G7L2A	All two stage burners
Wiring harness for burner control	06 41531 HGC	----	All
Wiring connector for igniter device	06 41531 HGC	----	All
Wiring harness for two stage burners	06 41621	----	All
Wiring terminals	06 41635	Entrelec	All
Reset switch/burner fail lamp	60 61988	----	All
Isolation transformer (not GB)	30 61610	3VA-E11TF102	When applied

10.3 AIR HANDLING SECTION

DESCRIPTION	PART NUMBER	MFGS. REF.	APPLICATION
Centrifugal blower	02 25751 01	BDC 241-241	STE 100
Centrifugal blower	02 25752 01	BDC 270-270	STE 125
Centrifugal blower	02 25753 01	BDC 321-321	STE 150-225
Centrifugal blower	02 25754 01	BPC 270-270	STE 300
Centrifugal blower	02 25756 01	BPC 321-321	STE 400
Fan motors	Specify: kW rating - phase - shaft size when ordering		

10.4 MISCELLANEOUS

DESCRIPTION	PART NUMBER	MFGS. REF.	APPLICATION
Combustion air fan impeller	02 25730	Punker	All
Sampling pressure test point	07 25811 02	M8	All
Silicon tubing	06 20224 cm	φ 5-8 mm x 1.0 m	All
Combustion fan assembly gasket	11 44696	---	All
Capillary seal plate assembly	08 07727	---	All
Differential pressure switch, air flow proving &/or clean filter control	30 60603	Dungs	All if options fitted
Air filters	see table 5 for details and part numbers		

**ALWAYS QUOTE MODEL SIZE/TYPE & SERIAL NUMBER WHEN ORDERING SPARES
TO COMPLY WITH CE CERTIFICATION ONLY AMBI-RAD APPROVED PARTS MAY BE FITTED.**

SECTION 11. GAS CONVERSION

- 11.1 This air heater is designed to operate on natural, propane or butane gas and will be supplied as ordered for the gas type specified. In the event it is required to convert to a different gas type to that which has been supplied, conversion of the gas burner must be carried out.
- 11.2 An Ambi-Rad approved conversion kit to suit the appropriate gas type must be used.

- 11.3 In addition to changing the burner injectors, and adjusting the gas pressure, sealing a governor or fitting a blanking plate it is necessary to fix data plate over stickers as supplied with the conversion kit of parts.
- 11.4 After conversion re-commission appliance according to section 7 of this document.

Figure 16 : Burner air shutter and setting dimension for all gases UK & IE

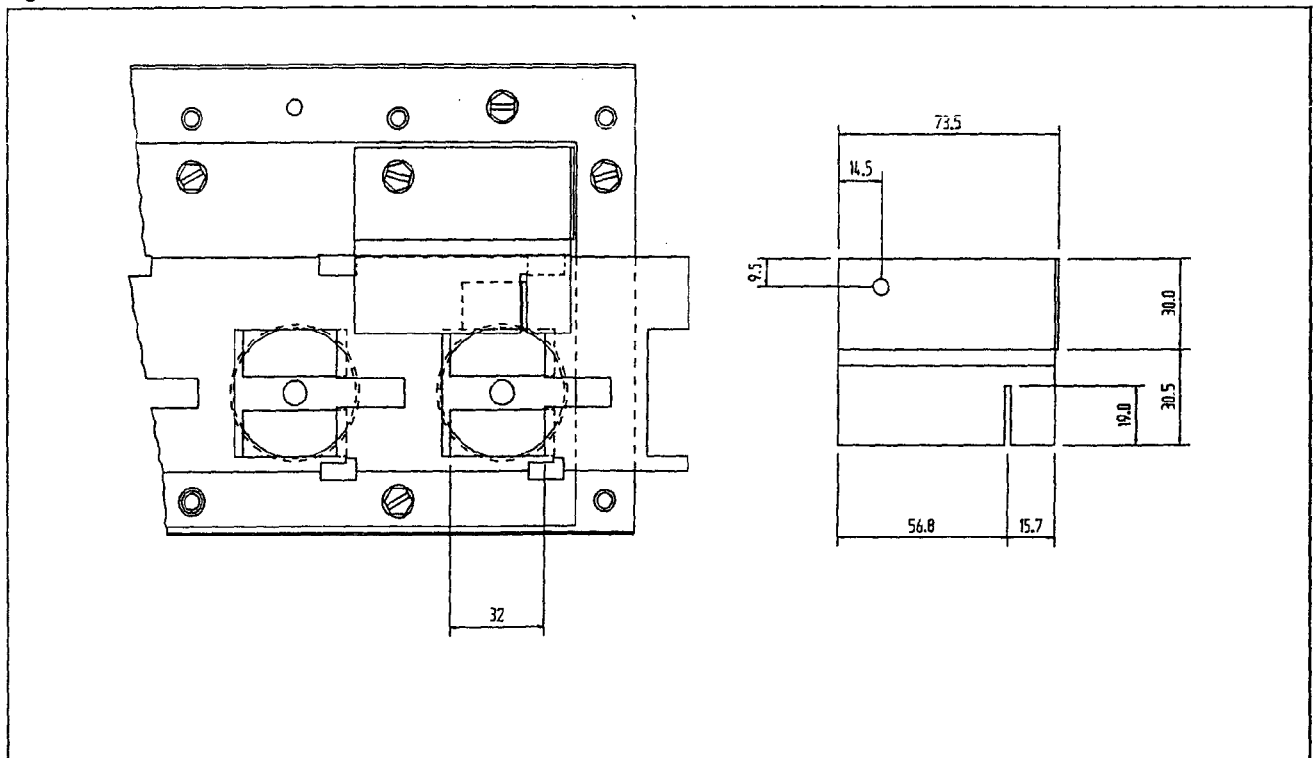

SECTION 12. HEALTH & SAFETY STATEMENT

Health and Safety Information for the Installer and Commissioning-Service Engineer

12.1 General

Under the Consumer Protection Act 1987 and Section 6 of the Health and Safety at Work Act 1974 we hereby provide the following information on substances hazardous to health.

Product range reference STE series 2 air heaters.

12.2 Cautionary note

During first firing some smoking may occur, this is due to the burning off of protective/lubricating oils used during appliance production. Most of this will have been removed during the production testing process. It is a wise precaution to ensure that adequate ventilation is provided during the initial firing and throughout the commissioning period, this is particularly important if the discharge air is to blow into a confined space. This smoking does not constitute a poison hazard.

12.3 Declaration

Ambi-Rad STE products contain no asbestos; copper is not employed in gas carrying components; solder which has a melting point below 450°C is not used; paints for corrosion protection and decoration are heat cured and contain no lead.

12.3.1 The above appliances meet the Electrical Safety requirements of EN60 335 Pt 1 1988.

12.4 Miscellaneous

Small quantities of adhesives and sealants used in the product are dried and cured and present no known hazard.

12.5 Insulation and Seals.

Material: Alumino - silicon fibre

Description: Tapes

Known hazards: Some people can suffer reddening and itching of the skin. Fibre entry into the eyes will cause foreign body irritation.

Inhalation will cause irritation to the respiratory tract.

Precautions: Wear protective gloves when handling.

People with a history of skin complaints may be susceptible to irritation.

Dust levels are only likely when the material is abraded.

In general normal handling and use for this purpose will not present discomfort. Follow

good hygiene practices, wash hands before consuming food or using the toilet.

First Aid: Medical attention must be sought following eye contact or prolonged reddening of the skin.

12.6 Thermostat. (Thermal overheat (limit) control LC3)

Material: Illuminating Kerosene.

Description: Sealed phial contains a small quantity in liquid form.

Recognition: Colourless liquid, paraffin oil/petroleum hydrocarbon odour.

Characteristics: Non-corrosive, flammable with no poisonous reference-CH poison Class 3

Precautions: Avoid handling. This product can irritate and defat the skin. Prolonged contact may cause dermatitis. Avoid breathing vapour. Avoid eye contact. Do not ingest.

First Aid: Skin. Wash thoroughly with soap and water.

Eyes. Rinse immediately with copious amounts of clean water.

Ingestion: Seek medical advice.

NOTE: If skin irritation persists seek medical advice.

12.7 Electrolytic Capacitor

Two types are used by random selection:

Recognition: 1. Plastic enclosure 2. Aluminium enclosure

Material: Contained liquid electrolyte

Known hazards: Electric shock possible if charged.

Precautions: Discharge to ground/earth. Do not incinerate.

First Aid: Treat for electric shock if affected.

END OF HEALTH AND SAFETY STATEMENT

SECTION 13. USER INSTRUCTIONS

13.1 OPERATING

How the air heater works:

Gas is burned by an atmospheric burner which fires into a heat exchanger. The gas burner is controlled by a double gas valve via an electronic burner control, which is actuated automatically via external controls i.e. a room thermostat and/or a time switch. The burner is ignited by a hot surface igniter. When the burner fires and warms the heat exchanger, the heat is sensed by a thermally actuated fan control which switches on the fan when the air temperature has reached its preset operating level.

At the end of a heating cycle the burner is switched off, the air circulation fan will continue to run until the air heater has cooled to a safe condition. Thereafter the fan will remain off until the next cycle is initiated.

Safety:

1. Flame failure is detected by the hot surface igniter which is also the sensor and will immediately result in gas valve shut down.
2. Safety against overheating is assured by two overheat controls. The first is an automatic recycle control which protects against low air flow i.e. clogged air ways, fan failure etc. The second, which is set to a higher level than the first one, is a control which locks out and switches off the burner in the event of gross overheating for any reason. Manual intervention is necessary to reset this control device. Resetting of the automatic burner control may also be required.
3. The location of the air heater should be maintained at normal atmospheric pressure. Changes to the building after air heater installation, should have regard to the heating installation, i.e. structural changes causing excessive draughts from doors, windows etc. Other air handlers and installation of air extraction equipment which may cause a negative pressure environment, can seriously affect the operation of this type of air heater, especially if combustion air supply is not ducted.

13.2 To light the heater:

1. Turn on the gas supply to the air heater.
2. Switch on the electricity supply to the air heater.
3. Ensure time switch (if fitted) is set to a 'ON' cycle.
4. Adjust control/room thermostat to desired temperature.
5. Air heater will light automatically when the room thermostat calls for heat.
6. If the appliance does not light:
 - a) check that the burner control does not

require resetting. An indicator light glows at the front panel of the appliance and on a remote control if fitted). Reset by pushing light/button on appliance or the remote control.

- b) check if thermal overheat control requires resetting (see fig. 15, key 16).
7. If the thermal overheat control requires resetting and doing so restarts the air heater, wait until the appliance warms to thermal equilibrium, to ensure the overheat control does not lock out again. If it does and the temperature near the heater is less than 30°C, then switch off the appliance and call for service. If the temperature is over 30°C, take appropriate action to reduce the ambient temperature near the air heater.

13.3 Air circulation:

1. The space heating process is for air to be circulated through the appliance whereby it gains heat from a heat exchanger. The air is directly discharged into the space to be heated. The air is eventually recirculated. Therefore it is very important that an unobstructed path for the circulation of the air will be maintained. This is particularly important if the air heater has been installed to blow through the wall between two rooms.
2. Sometimes the air circulation fan of the appliance is connected to a remote over-ride switch. This enables cool air to be used for circulation purposes when the air heater is not used for heating purposes e.g. in summer.

To use this feature:

 - a) switch ON electricity
 - b) switch ON manual override switch, this may be fitted as a feature on a remote composite control.

13.4 Maintenance:

1. Maintenance and service must only be carried out by appropriately qualified persons e.g. "Corgi" registered undertakings.
2. It is in your interest to ensure proper service and maintenance is carried out at a regular basis. Periods between service are dependent upon the local environment where the heater is installed. All gas appliances should be serviced at least once a year.
3. In case of any damage to the appliance, it must be shut down completely and checked by an appropriately qualified person.
4. In the event of difficulties in resolving any of these matters, please do not hesitate to contact Ambi-Rad.

